

CONTROL FOR MAPPING

by Geodetic and Photogrammetric Methods

**REPORT ON COLLOQUIUM HELD AT
THE UNIVERSITY OF NEW SOUTH WALES**

22-24 MAY, 1967

EDITOR: P. V. ANGUS-LEPPAN

CONTROL FOR MAPPING

CONTROL FOR MAPPING

by Geodetic and Photogrammetric Methods

**REPORT ON COLLOQUIUM HELD AT
THE UNIVERSITY OF NEW SOUTH WALES**

22-24 MAY, 1967

EDITOR: P. V. ANGUS-LEPPAN

**DEPARTMENT OF SURVEYING
THE UNIVERSITY OF NEW SOUTH WALES
P.O. BOX 1, KENSINGTON, N.S.W., 2033**

PRICE: \$3.00 plus 25 cents postage

PREFACE

In all forms of mapping, the provision of control is an important initial phase. The observations and adjustment of the Geodetic Survey of Australia have been recently completed. One of the chief uses of the geodetic control will be to form the basis for mapping control. At the same time an ambitious programme of mapping the whole continent at a scale of 1/100 000 has commenced, and numerous extensive engineering projects require additional mapping.

With all this activity, it was an appropriate time to discuss 'Control for Mapping'. The many new developments both in Geodesy and Photogrammetry make it difficult to keep in touch with new developments, and Australia's physical isolation increases the difficulty. Although the National Mapping Council has a Technical Sub-Committee which meets regularly, there is insufficient communication between mapping organisations and the Universities. This Colloquium provided the first opportunity for discussions and exchange of ideas, but it is hoped to organise similar meetings at intervals.

The colloquium was sponsored jointly by the Department of Surveying, University of New South Wales, and the Association of Surveying Lecturers of Australasia. The organising committee consisted of P.V. Angus-Leppan, J.G. Freislich and L. Eekhout.

Some of the papers have been slightly modified because they were originally presented with numerous slide illustrations, and others have been abbreviated by the omission of appendices. Discussion has been summarised and edited.

Thanks are due to the members of the organising committee and other members of staff of the Department of Surveying for their assistance in the organisation and in recording the discussion. The editor wishes to express sincere thanks to Mrs. F. Osborne for her devotion to the task of typing the proceedings; the Director of National Mapping for providing maps and illustrations for the papers by members of his staff; to Mr. D.S. Howie of the University Publications Section; Mr. E.D. Foster; and Mrs. P. Angus-Leppan for assistance in reading the proofs.

University of New South Wales,
Sydney.
September 1967

P.V. Angus-Leppan.
Editor.

CONTENTS

PREFACE	vii
AUTHORS	x
LIST OF PARTICIPANTS	xiii
OPENING SESSION - The Hon. T.L. Lewis, Minister for Lands	1
1. MAPPING THE MOON - G. Konecny	2
2. ANALYTICAL AERIAL TRIANGULATION IN TASMANIA - M.T. Noonan	30
3. AEROTRIANGULATION TECHNIQUE IN NEW SOUTH WALES - A. Zvirgzdins	42
4. STEREOCOMPARATOR PROGRAMMES ON THE HONEYWELL 400 COMPUTER - E. Chambers	55
5. CONTROL FOR AND BY BLOCK ADJUSTMENT IN VICTORIA - F.H. Edwards	70
Discussion	88
6. AUTOMATION IN PHOTOGRAMMETRY - G. Konecny	96
Discussion	120
7. PROBLEMS ENCOUNTERED IN THE USE OF THIRD ORDER LEVELLING FOR THE NATIONAL LEVELLING GRID - K. Leppert	123
8. LEVELLING IN NEW SOUTH WALES SINCE WORLD WAR II - P.R. Seidel	135
Discussion	146

9.	CONTROL SURVEYS FOR 1/100,000 SCALE MAPPING - J.D. Lines	152
10.	AUSTRALIAN DEVELOPMENTS IN THE USE OF HOVERING HELICOPTERS TO ESTABLISH SURVEY CONTROL - W. Child	170
11.	APPLICATION OF AERODIST MEASURING EQUIPMENT TO MAPPING CONTROL - E.U. Anderson	181
	Discussion	199
12.	THE APPLICATION OF WEIGHTS TO LEAST SQUARES ADJUSTMENT - A.G. Bomford	206
13.	LEAST SQUARES ADJUSTMENT OF OBSERVATIONS - J.S. Allman	209
14.	EFFECT OF CORRELATED MEASUREMENTS ON ERROR PROPAGATION IN A TRIANGULATION STRIP - S. Bervoets	240
	Discussion	262
15.	CONTROL SURVEYS FOR PHOTOGRAMMETRIC MAPPING AT LARGE SCALES - W.A.G. Mueller	267
16.	MAPPING CONTROL FOR HYDRO-ELECTRIC DEVELOPMENT IN TASMANIA - J.W.S. Linton, D. Jenkins, A. Apseniaks	289
	Discussion	315
17.	PHOTOGRAMMETRIC PLANIMETRIC ADJUSTMENT - D.R. Hocking	320

AUTHORS OF PAPERS.

- G. KONECNY. Dr. Ing, M.S.; Professor and Head of Department of Surveying Engineering at the University of New Brunswick; Visiting Professor, University of New South Wales. (April-June 1967).
- M.T. NOONAN. B.Sc., A.M.A.I.C.; Chief Computer, Department of Lands and Surveys, Tasmania.
- A. ZVIRGZDINS. Dipl. Eng., M.A.I.C.; Chief Photogrammetrist, Department of Lands, N.S.W.
- E. CHAMBERS. B.Surv., A.M.A.I.C., Assoc. I.S.Aust.; Research Division of Central Mapping Authority, Department of Lands, N.S.W.
- F.H. EDWARDS. M.Surv., M.I.S.Aust.; Superintending Photogrammetrist, Department of Lands and Surveys, Victoria.
- K. LEPPERT. Dipl. Ing., M.I.S.Aust., M.A.I.C.; Officer in Charge, Levelling Section, Division of National Mapping.
- P.R. SEIDEL. M.I.S.Aust., M.A.I.C.; Central Mapping Authority, Department of Lands, N.S.W.
- J.D. LINES. L.S., M.I.S.Aust., M.A.I.C.; Assistant Director, Division of National Mapping.
- W. CHILD. Major, Royal Australian Survey Corps.
- E.U. ANDERSON. Major, Royal Australian Survey Corps.
- A.G. BOMFORD. M.A., A.R.I.C.S., M.I.S.Aust., M.A.I.C.; Division of National Mapping.
- J.S. ALLMAN. B.Surv., Assoc. I.S.Aust., M.A.I.C.; Lecturer in Surveying, University of New South Wales.

S.G. BERVOETS. Ir.Geod. (Delft), M.A.I.C.; Senior Lecturer in
Surveying, University of Melbourne.

W.A.G. MUELLER. Dipl.Ing., M.I.S.Aust.; Supervising Surveyor
in Photogrammetry, Snowy Mountains Hydro-Electric Authority.

J.W.S. LINTON. L.S., M.I.S.Aust., M.A.I.C.; Deputy Supervising
Surveyor, Hydro-Electric Commission, Tasmania.

D. JENKINS. Assoc.I.S. Aust., M.A.I.C.; Senior Surveyor,
Hydro-Electric Commission, Tasmania.

A. APSENIIEKS. A.M.A.I.C.; Photogrammetrist-in-Charge,
Hydro-Electric Commission, Tasmania.

D.R. HOCKING. M.I.S.Aust., M.A.I.C.; Chief Drafting Officer,
Division of National Mapping.

PARTICIPANTS

Allman, J.S.	University of New South Wales	N.S.W.
Anderson, E.W.	Royal Australian Survey Corps	Vic.
Anderson, L.	Department of Lands	N.S.W.
Angus-Leppan, P.V.	University of New South Wales	N.S.W.
Apsenieks, A.	Hydro-Electric Commission	Tasmania
Barrie, J.K.	Australian Aerial Mapping	N.S.W.
Bellamy, R.	Department of Main Roads	N.S.W.
Bennett, G.G.	University of New South Wales	N.S.W.
Bervoets, S.G.	University of Melbourne	Vic.
Bomford, A.G.	Division of National Mapping	A.C.T.
Brennan, B.F.	Monash University	Vic.
Calderwood, G.C.		A.C.T.
Cameron, I.K.	Royal Melbourne Institute of Technology	Vic.
Cawthorne, A.	Laurie and Montgomerie	N.S.W.
Chambers, E.	Department of Lands	N.S.W.
Child, W.	Royal Australian Survey Corps	Vic.
Cocks, G.J.	Mapmakers	N.S.W.
Cooper, P.B.	Department of Main Roads	N.S.W.
Davies, P.B.	Department of Main Roads	N.S.W.
Dowman, I.J.	Mapmakers	N.S.W.
Edwards, F.H.	Department of Lands and Surveys	Vic.
Eekhout, L.	University of New South Wales	N.S.W.
Fletcher, L.N.	Surveyor-General, Department of Lands	N.S.W.
Freislich, J.G.	University of New South Wales	N.S.W.
Harley, I.	University of Queensland	Qld.
Hearfield, F.W.	Forestry Commission	N.S.W.
Herridge, J.K.	Department of Main Roads	N.S.W.
Hocking, D.R.	Division of National Mapping	Vic.
Humphries, B.	Department of Main Roads	N.S.W.
Jenkins, D.M.	Hydro-Electric Commission	Tas.
Johnson, F.L.	Wordsworth and Associates, Young.	N.S.W.
Johnson, R.	Department of Lands	N.S.W.
Jones, P.B.	University of Sydney	N.S.W.
Kearsley, W.	Department of Lands	N.S.W.
Kirsch, H.	Snowy Mountains Authority	N.S.W.
Konecny, G.	University of New Brunswick	Canada
Laurie, J.J.	Laurie and Montgomerie	N.S.W.
Leahy, F.J.	University of Melbourne	Vic.
Lenehan, A.T.	Department of Main Roads	N.S.W.
Leppert, K.	Division of National Mapping	A.C.T.
Lines, J.D.	Division of National Mapping	Vic.
Linton, J.W.S.	Hydro-Electric Commission	Tas.
Mather, R.S.	University of New South Wales	N.S.W.
McKinlay, B.	Department of Main Roads	N.S.W.
Mitchell, J.E.	Department of Lands and Surveys	Vic.
Molyneux, R.J.	Jones, Flint and Pyke	Qld.
Mueller, W.A.G.	Snowy Mountains Authority	N.S.W.
Noonan, M.T.	Department of Lands and Surveys	Tas.
Ostoja, B.	University of New South Wales	N.S.W.
Ovington, J.	Australian Aerial Mapping	N.S.W.
Powell, I.	Department of Lands	N.S.W.
Prins, P.J.	QASCO	Qld.
Purins, B.	Department of Lands	N.S.W.
Rassaby, H.S.	Department of Lands	N.S.W.
Seidel, P.R.	Department of Lands	N.S.W.
Shephard, A.	Laurie and Montgomerie	N.S.W.
Smith, W.R.B.	Department of Main Roads	N.S.W.
Spowers, A.	Department of Lands	Qld.
Stolz, A.	S.A. Institute of Technology	S.A.
Tait, J.G.	Australian Aerial Mapping	N.S.W.
Thomson, G.H.V.	Royal Melbourne Institute of Technology	Vic.
Trinder, J.	University of New South Wales	N.S.W.
Werner, A.P.H.	University of New South Wales	N.S.W.
White, L.A.	University of Newcastle	N.S.W.
Zvirgzdins, A.	Department of Lands	N.S.W.

OPENING SESSION

The CHAIRMAN, Professor P.V. Angus-Leppan welcomed all participants and introduced the MINISTER FOR LANDS, Mr. T.L. Lewis.

The Minister spoke of the importance of mapping to the community and stated that some reassessment of map specifications might be necessary. He wondered whether the community could be best served by maps in which customary standards were somewhat relaxed. He mentioned a recent trip in the Western Divisions in which the maps produced by a petroleum company were used in air navigation.

Mr. Lewis commended the organisers of the colloquium and wished participants success in their discussions.

The Chairman thanked the Minister for his attendance and his interesting and thought-provoking speech.

MAPPING THE MOON

by

G. Konecny

1. Introduction

Since ancient times the moon has evoked the curiosity of the human mind. Even very primitive cultures have used it as a timekeeping device. The age of exploration and rationalism brought about the development of mapping on the earth, while objects in the sky seemed so far out of reach, that only a casual interest was given by astronomers to locate and name various features on the moon's surface. About 70 years ago the telescopes of various astronomical observatories began to be used for lunar earth-based photography. Various small-scale planimetric maps resulted from these efforts, usually showing the entire visible surface of the moon in an orthographic view. In these maps relative crater heights were determined from shadow lengths, but due to a rather arbitrary choice of a lunar datum the lunar co-ordinates latitude, longitude and height varied greatly between maps produced by various observatories.

The first accelerated attempts to map the moon in detail came after it had been established that space flight was possible, and that the moon could become a target for man's exploration.

This paper has been slightly modified from the original presentation which included numerous slide illustrations.

2. The U.S. Space Programme

Shortly after the Russian successes of "Sputnik" to put a spacecraft into orbit around the earth and of "Lunik" to send a spacecraft to the moon the United States Government embarked on a large scale space exploration programme. Part of it is directed to explore earth from space; the "Tiros" satellites of the U.S. Weather Bureau for example concentrated on exploring the earth's atmosphere. The main effort, however, has gone into plans to explore extra-terrestrial objects by unmanned or manned missions.

Manned Space Flights. The National Aeronautics and Space Administration (NASA) began to develop techniques for manned spaceflights with project "Mercury". In 9 "Mercury" missions launch, orbit and landing manoeuvres were studied from 1960 to 1963. Project "Gemini" in its 12 missions between 1964 and 1966 put two astronauts into orbit; extravehicular activities were studied and the docking with a separate target vehicle, the "Agena", was successfully completed.

Project "Apollo" has the objective of putting 3 men into orbit around the moon and returning them to earth; two of them are to leave the orbiting vehicle in a smaller spacecraft, the "Lunar Landing Module". They are to land on the lunar surface; after gathering samples of lunar rocks they are to return with the Lunar Landing Module to the orbiting spacecraft, and with its help back to the earth. Despite the tragedy during Apollo mission 1 it is hoped to achieve this objective by 1970.

While the manned space efforts are being directed from NASA's Manned Spacecraft Center in Houston, various centres in the United States work on their preparation under subcontract or in co-operation with NASA laboratories.

Planetary Exploration. These comprise the various exploration efforts of extra-terrestrial bodies, earth-based, or from space vehicles carrying a variety of sensors. Such vehicles have already been successfully launched to obtain information from other planets: "Mariner 2" transmitted radiometric information on Venus as early as 1962. In July 1965 "Mariner 4" transmitted a series of TV-pictures from Mars taken from 5400 miles above its surface.

By far the greatest exploration effort is directed toward the moon to prepare for the manned landing.

Lunar Mapping from Earth-Based Photography. At the start a mapping programme was organised to produce detailed lunar maps from earth-based photography by the Aeronautical Chart and Information Center (ACIC). Two observatories situated at high elevation above sea level, at Pic du Midi in France and at Flagstaff, Arizona, gathered lunar photography by means of long focus refractor telescopes fitted with an aerial camera. The ACIC compiled maps at the scale 1:1000 000 with 300m. contours. As datum a sphere of radius 1738km. was chosen. The orientation of the datum is as given by Schrutka-Rechtenstamm (1958) (1), who adjusted the astronomic measurements of 150 lunar points carried out over the full range of libration. This periodic variation of lunar surface points in comparison to the moon's centre of $\pm 8.1^{\circ}$ in latitude and $\pm 6.8^{\circ}$ in longitude can be used effectively to create an apparent stereoscopic parallax corresponding to about 10 times the earth's diameter, simply choosing lunar photographs at extreme libration times.

The ACIC maps cover the moon's visible area in 84 sheets of the size 56 by 73cm. The equatorial area is imaged in the Mercator projection, the polar areas in stereographic projection tangent to the poles, and the mid-latitudes in Lambert conic conformal projection. The planimetry was transferred by rectification of photographic parts to a controlled grid based on the chosen datum. Contours were interpolated using the control; relative elevations were found using shadow heights of craters and the inclination of moderately inclined surfaces was estimated using photometric techniques, originally proposed by Van Diggelen (2).

The Army Map Service (AMS) produced maps from these earth-based photographs by stereophotogrammetric techniques. Special instrumentation according to the Kelsh Plotter principle was designed to accommodate the focal lengths and special projection conditions encountered with the type of photography used. The projection used was a general azimuthal projection, similar to an equatorial stereographic projection, except that the projection point lies at $5/4$ of the lunar radius through origin and the moon's centre extending outside the moon on its invisible hemisphere. These topographic maps were compiled at scales 1:2500 000 and 1:5000 000 over the visible hemisphere. As far as relative heights are concerned, they agree within 500m. between ACIC and AMS map types.

Lunar Datum. The Army Map Service also made some investigations of the Schrutka-Rechtenstamm datum. 254 points were selected and fitted to a triaxial ellipsoid. The standard error of the fit was ± 1.7 km. per point.

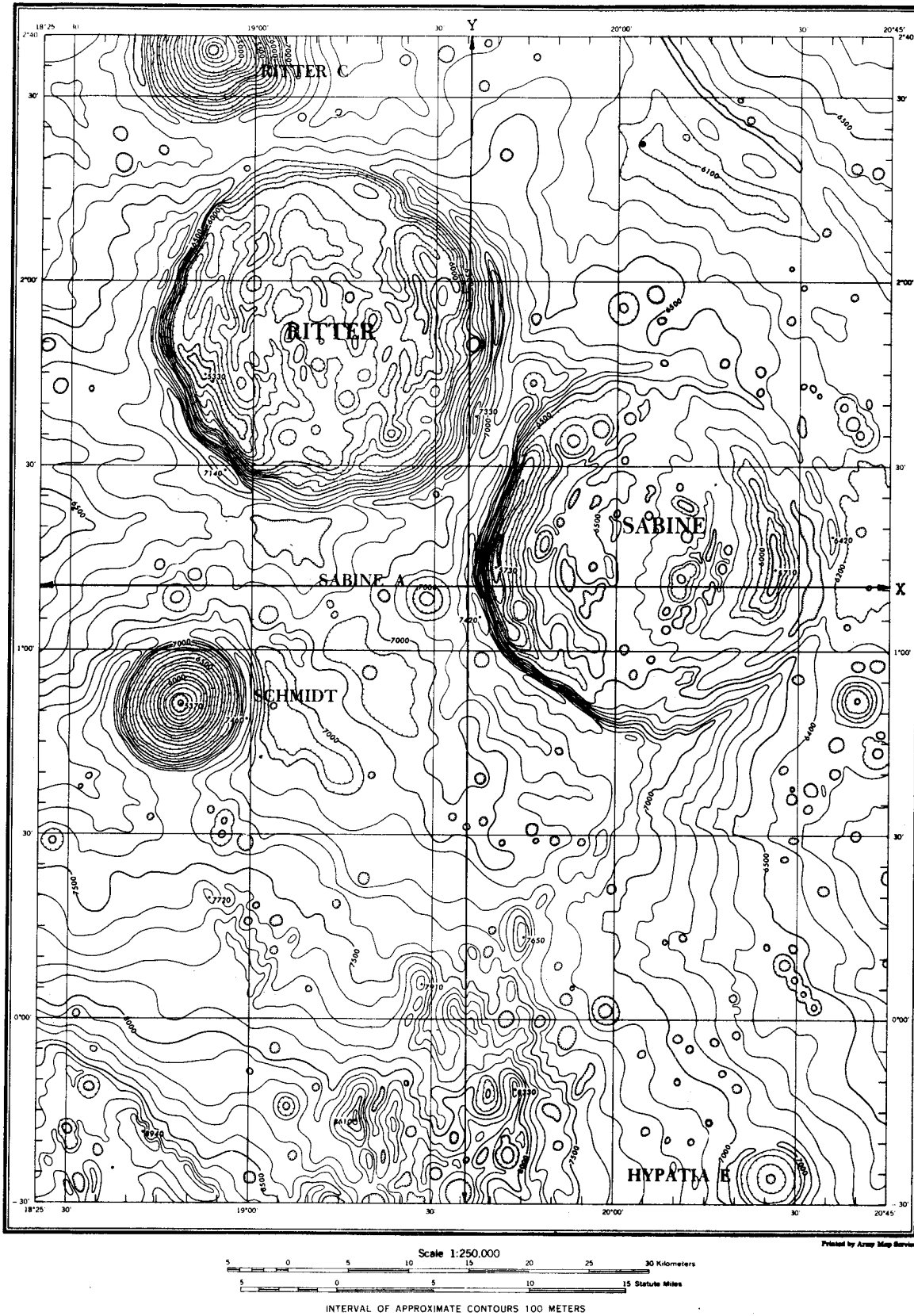

FIGURE 1.1 Topographic map compiled from Ranger 8 photography using comparator/analytical and digital contouring techniques.

Prepared for NASA by U.S. Army Map Service.

The axes determined were:

- a = 1735.6km, East axis
- b = 1738.6km, North axis
- c = 1743.4km, axis toward earth

An evaluation by spherical harmonics using symmetry conditions for a and b resulted in

- a = 1737.5km
- b = 1737.5km
- c = 1741.1km

Until there is an opportunity to confirm these figures by the dynamic behaviour of satellites orbiting the moon, changes of the Schrutka-Rechtenstamm datum are not yet justified.

Ranger Programme. The ACIC and the AMS maps provided the geometrical basis on which geological interpretation of the lunar regions was undertaken by the U.S. Geological Survey. To study the lunar surface characteristics close-up views of the moon's surface were needed. These were provided by the missions "Ranger 7" to "Ranger 9" from 1964 to 1965. These spaceflights were directed to transmit large scale lunar photographs shortly before impact. The "Ranger" spacecrafts carried 6 vidicon-TV-cameras of a 1 x 1 inch format, 3 of which had 1" wide angle lenses, and the other 3 were equipped with 3" narrow angle lenses. One camera of each type utilised a complete 0.44 square inch vidicon transmission pattern for distant photography and two cameras of each type used a partial, fast 0.11 square inch partial scan pattern for photographs immediately before impact. The resolution of the final two photographs of 2 feet is about 1300 times better than that of earth-based lunar photography. It was used for a detailed surface analysis.

The Army Map Service also attempted to use photographs of mission "Ranger 8" for experimental mapping purposes (3). Maps of the impact area were compiled at scales 1:250 000 with 100m. contours (Figure 1.1) and 1:50 000 with 50m. contours. To control the area an average of 9 points were identified on each Ranger photograph and on a number of earth-based observatory photographs. A three-dimensional adjustment procedure established the control for each photograph.

GROUND FORMAT

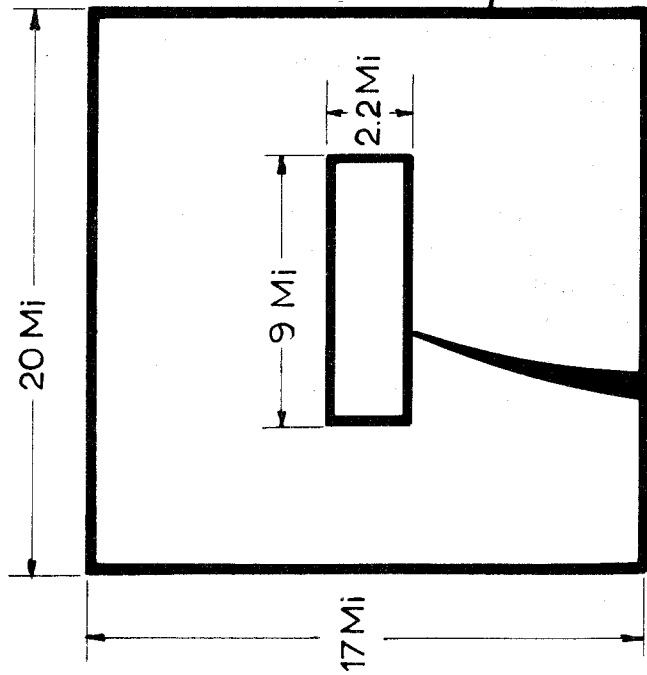

EDGE DATA STRIP - INCLUDES
9 LEVEL GRAY SCALE AND
RESOLVING POWER CHARTS.

DIRECTION OF
SPACECRAFT
MOVEMENT

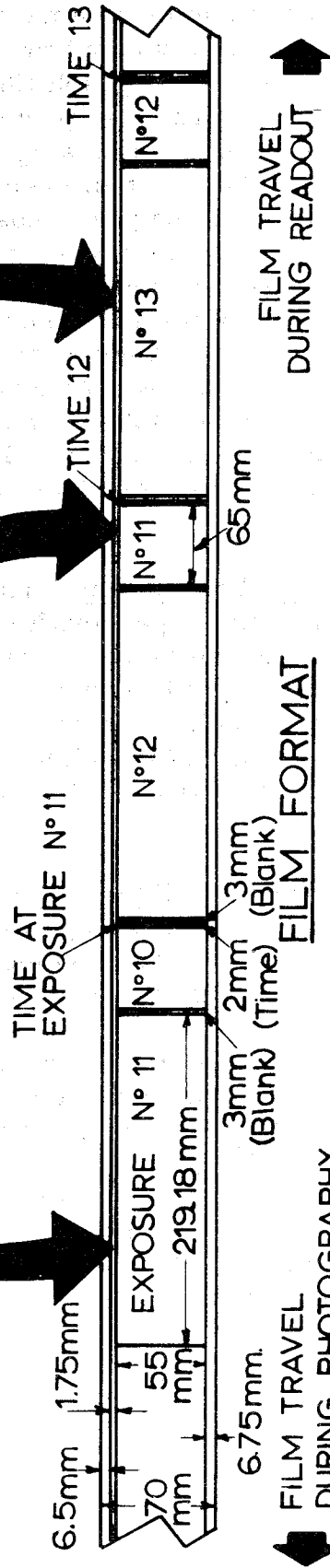
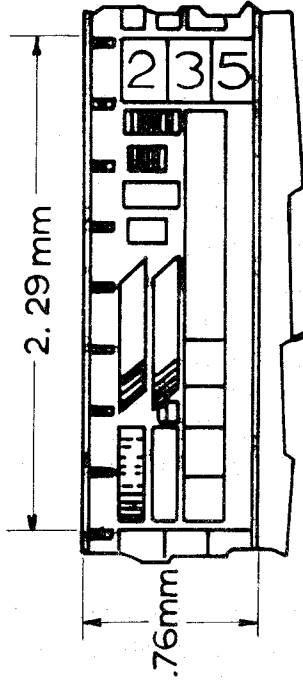

FIG.1.2 DETAILS OF GROUND COVERAGE, EDGE DATA AND FILM
FORMAT OF LUNAR ORBITER PHOTOGRAPHY.

Mapping procedures required the use of special techniques, since the small base-height ratios (the trajectory was at a steep angle) or excessive common camera tilts did not permit the use of conventional stereoplotters without modification. One adopted procedure, in which a Zeiss Stereoplanigraph C8 was fitted with two Balplex projectors to increase its ranges, permitted X, Y, Z measurements of about 800 points per model characterising the model surface. Proper rotation of the model could not be accomplished due to range limitations of the instrument, and therefore an analytical space transformation of the 800 points and the use of digital contouring techniques as an interpolation between the transformed point positions and heights were adopted. Another procedure used Zeiss PSK stereocomparator measurements for the numerical determination of model co-ordinates, which were then transformed in the same manner to permit digital contouring. A third procedure permitted the direct plotting of Ranger photographs in the OMI-Bendix Analytical Plotter AP-2 (or AS-11-A in military terms). The 16mm. format negatives were enlarged in each case for use in the respective instruments.

Surveyor Programme. The "Surveyor" programme in 1966 was designed to soft-land a spacecraft on the moon and to transmit photographs of its surface at the landing site similar to those of the Russian spacecraft "Luna 9". The "Surveyor 1" surface photos permit recognition of a lunar rock of 10 inch length and a crater with the diameter of a few feet. The Surveyor cameras are of the vidicon type and possess lenses which can be zoomed from a focal length of 1" to a focal length of 4".

Lunar Orbiter Programme. Since August 1966 3 "Lunar Orbiter" missions have been successfully carried out. Their purpose is to provide large scale photographs of selected portions of the lunar surface, on the basis of which potential landing sites for project "Apollo" may be made.

There are altogether 10 sites between latitudes 5°N and 5°S , 60°W and 45°E which come into closer consideration for photography. Each site covers 16 exposures. They are taken simultaneously with an 80mm. focal length and with a 610mm. focal length onto film with 70mm. width from a spacecraft altitude of 46km. The neat area of a wide-angle exposure covers 65 x 55mm. of film and an area of 20 x 17 miles with a ground resolution of 8 metres. A high resolution exposure covers 219.18 x 55mm. of film and an area of 9 x 22 miles at a ground resolution of 1 metre. (Figure 1.2)

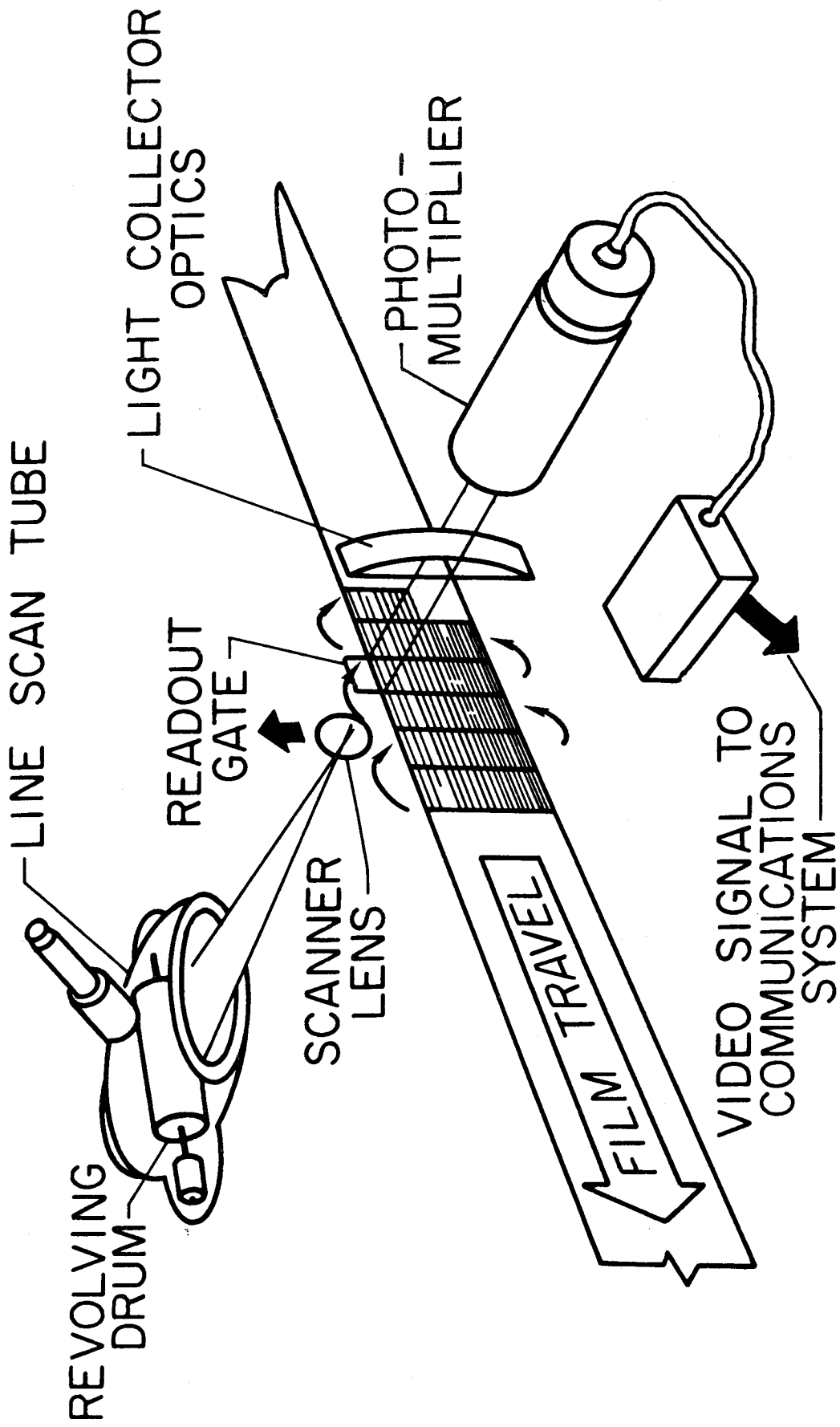

NASA

FIGURE 1.3 Lunar Orbiter photographic system read-out. Schematic.

The edge of the film strip carries a pre-exposed pattern of resolving power charts and a 9 level gray scale, which permit a subsequent photogrammetric and photometric calibration of each photo. The time of exposure is accurately coded onto the film.

The photographic system consists of 3 parts: the camera, the processor, and the readout. Each part is separated by a series of loopers which permit the system to operate and transport the film through each part separately, without affecting the other parts. After each exposure, for both lens systems onto one film, the film is advanced into the camera looper. After all photos are taken the camera looper feeds the film for Bimat-processing through the processor drum and the dryer onto the readout looper. After the development is completed the film is passed through the film scanner onto the take-up looper. (Figure 1.3)

To photograph the 10 sites a descending orbit was selected. To achieve optimum contrast conditions for the photographs a sun angle between 55° and 70° is required. Since the sites are about 105° apart in longitude it takes 9 days to obtain photographs of all 10 sites at ideal lighting conditions. The photography period is therefore completed at the 10th day after start of the final orbit. The readout period continues to about the 27th day. During the readout signals are transmitted while the Orbiter is on the earth-side of the moon. They can be picked up sequentially by one of the 4 tracking stations: Goldstone, California; Johannesburg; Woomera; and Madrid. The signals are passed to the Jet Propulsion Laboratory in Pasadena, California, for further processing.

In order to preserve the high photographic resolution and as much of the geometric and photometric fidelity as possible, the exposed and developed film is read out in small scan units, called "framelets". (Figure 1.4) One wide-angle or medium resolution photograph contains 28 framelets. A site is covered by 16 exposures which overlap by 87%. A total of 2436 medium resolution framelets constitute one site. One such framelet covers an area of 2 x 55mm. on the original film.

A high resolution exposure only overlaps to 5%; there are also 16 exposures per site; each exposure contains 96 framelets also of an area 2 x 55mm. on the original film.

The framelet readout produces an analog video signal which is modulated by the photographic density information. After reception the

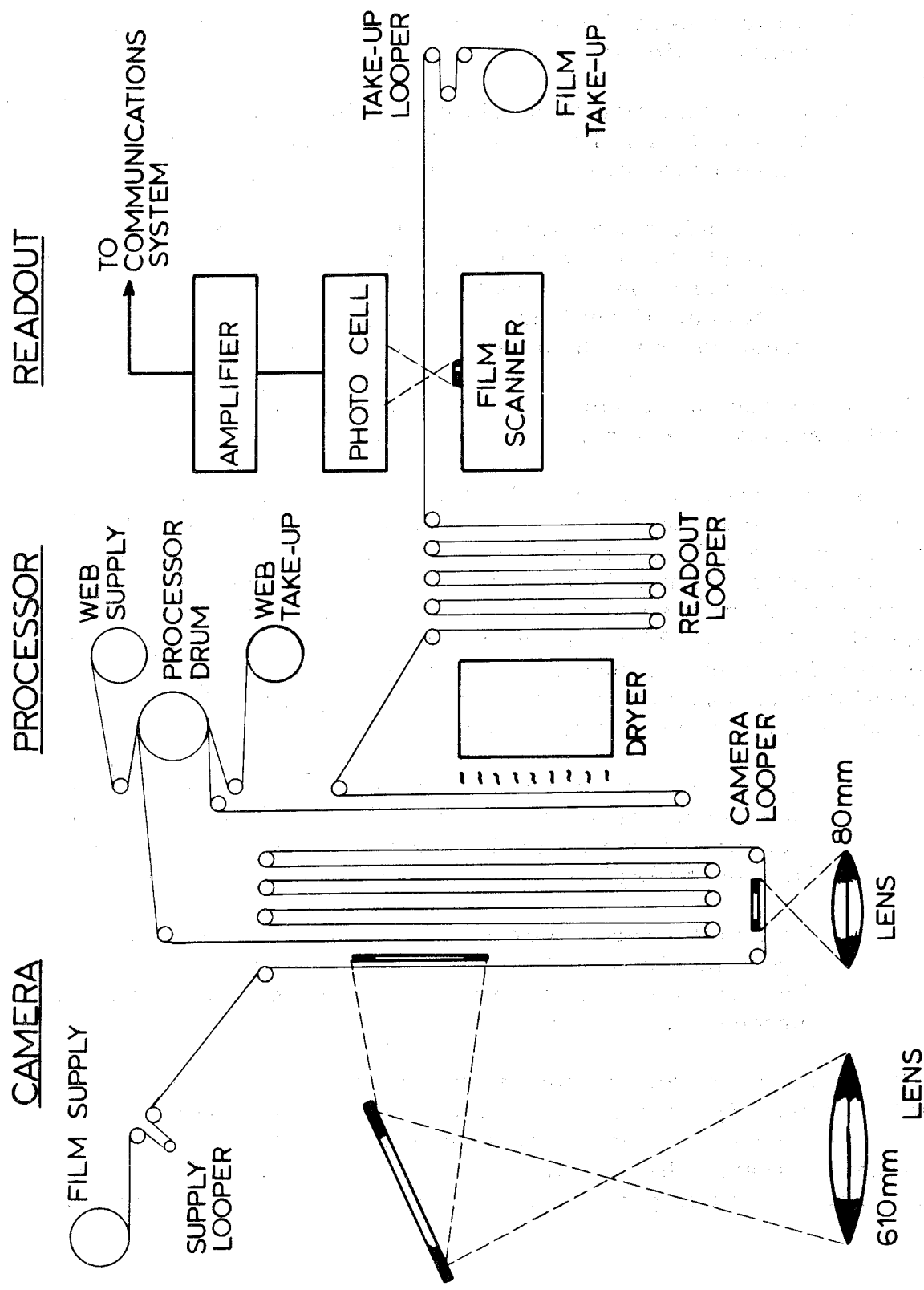

FIG. 1.4. LUNAR ORBITER PHOTOGRAPHIC SYSTEM. SCHEMATIC.

signal is made available for evaluation in three different forms:

1. a film record showing the demodulated video signals in a voltage - time sequence.
2. a reconstruction of the video-signals for each framelet in form of 35mm. film. Each framelet therefore has an approximate size of 22 x 605mm. in the reconstruction.
3. 14 framelets each are reassembled at a scale of 6 times the original film for observation of the photographs in subframes. Each subframe overlaps by 1 framelet with the adjacent subframe. From these the entire photographs may be recomposed by photographic reproduction.

Figure 1.5 shows part of medium resolution subframe and Figure 1.6 part of high resolution subframe.

These records are to be used for selecting the best possible landing site of the Lunar Excursion Module. This has a span of about 6m. between its legs. In order that it may return to the orbiting spacecraft the landing surface should not be inclined by more than 12° from the horizontal. A landing site must therefore be selected, where there are no slopes exceeding 12° . The probability of directing the Lunar Excursion Module to a predetermined spot is expressed by a series of concentric ellipses. A 99% probability ellipse covers an area of about 3 by 5km. The mapping programme consists of the following tasks:

1. to measure and evaluate lunar slopes of a number of areas selected by visual inspection, and to determine a probability landing ellipse with the least slope and with no slope exceeding 12° for the leg base of the Lunar Excursion Module.
2. to map the radar approach ray so that the automatically operating Doppler Radar control system will not be upset by unexpected topographical disturbances during the landing procedure.

These tasks are being performed at the Mapping Sciences Laboratory of the NASA Manned Spacecraft Center in Houston, Texas, where I had the opportunity to become involved with these mapping problems for 8 months of my sabbatical year. The laboratory is jointly operated by NASA, the Lockheed Electronics Company and the Autometric Operation of Raytheon.

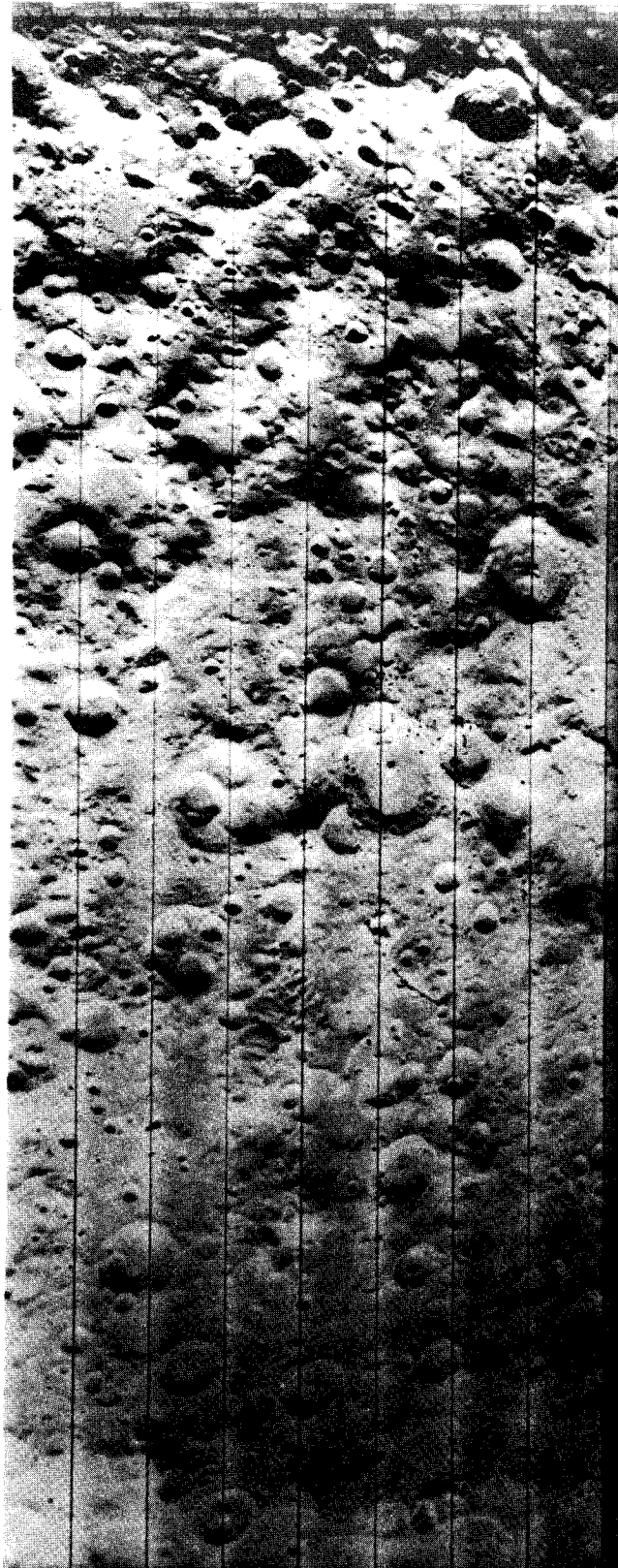

FIGURE 1.5 Lunar Orbiter photography: part of medium resolution photograph. Photo courtesy of National Aeronautics and Space Administration.

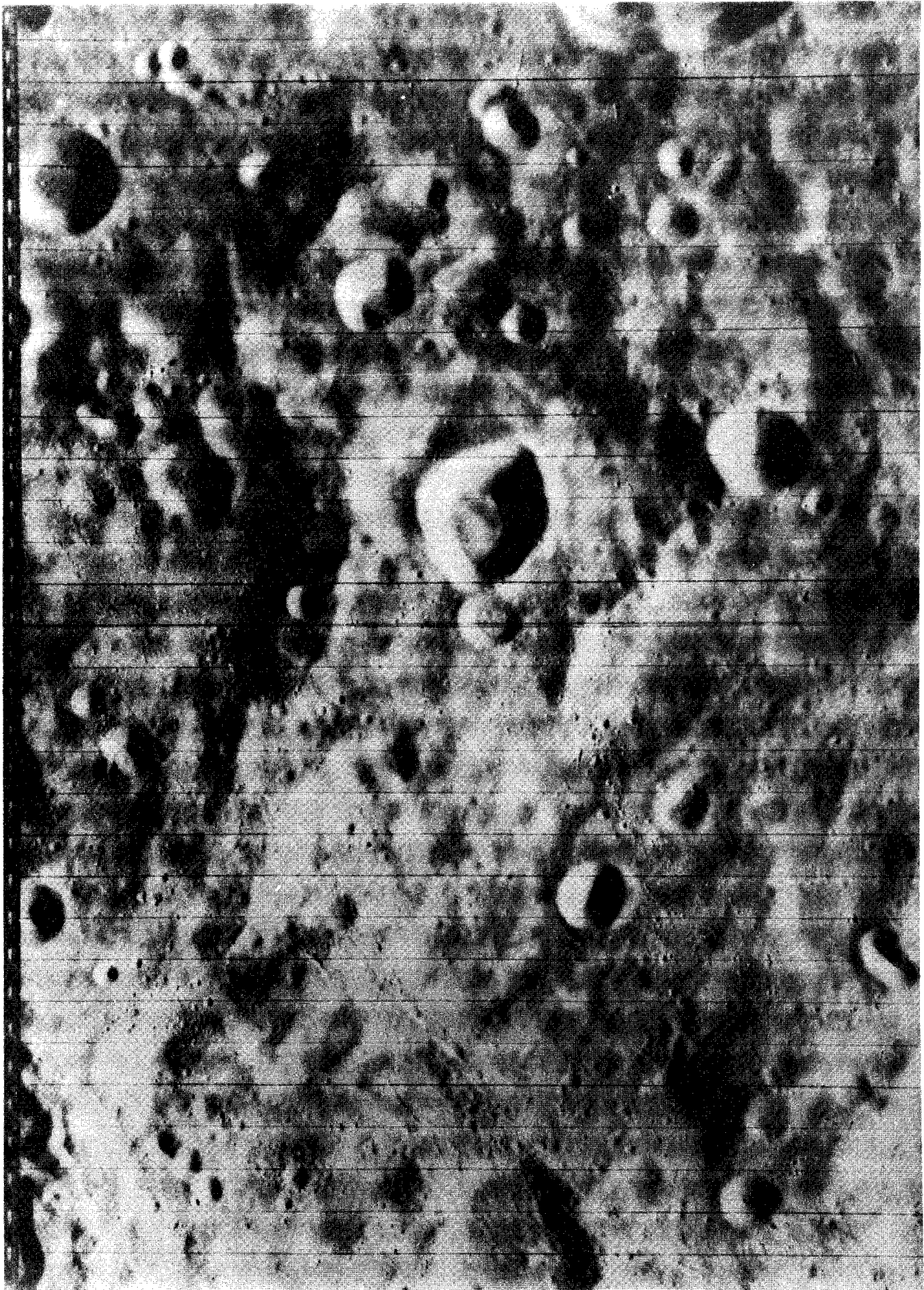

FIGURE 1.6 Lunar Orbiter photography: part of high resolution photograph.
Photo courtesy of National Aeronautics and Space Administration.

Three other U.S. agencies are working under subcontract in co-operation with the Manned Spacecraft Center on the mapping project: the Longley NASA Research Center in Hampton, Virginia, the U.S. Geological Survey, and the Aeronautical Chart and Information Center.

3. Reduction of Lunar Orbiter Photographs

Control by Aerial Triangulation. Tracking of the Orbit and the recorded timing of the photographic exposures permits determination of the position of the exposure station within the relative accuracy of a metre. The verticality of the cameras is stabilized within narrow limits by a sun- and a Canopus-sensor which also permit determination of the exact camera orientation. These auxiliary data provide better information than is customary for aerial photography.

The problems of control extension, however, are rooted in the many sources of geometric infidelity of the Lunar Orbiter image, most of all in the transmission of the photographic image, which involves the transformation of the photographic image into a voltage-time sequence and back into a photograph. For this two scanners must be used which are unavoidably affected by scale linearity errors.

While the Orbiter images are best viewed in subframes or assembled pictures, they must be evaluated framelet by framelet.

For stereo-evaluations, which include photogrammetric mapping and aerial triangulation, only the medium resolution photographs provide sufficient overlap. Using only every third medium resolution photograph would provide for a 61% overlap, which could be used for evaluations of the assembled photographs in a conventional manner. The distortions between framelets are of such a magnitude, however, that it is advisable to use every framelet of every photo for a more accurate result of the aerial triangulation.

For this purpose the 35mm. framelets of part of a subframe are copied side by side on 9 x 18" glass plate. Corresponding subframe-parts of the overlapping photographs are likewise copied onto 9 x 18" plates. The plates are used under a special stereoscope in conjunction with Zeiss snap markers to select and to transfer as a rule 16 transfer points for every framelet. A 60% overlap will thus be characterized by 10 x 28, or 280 transfer points instead of the customary 6 points in standard aerial triangulation.

The photoco-ordinates of the points and the edge-data calibration marks corresponding to each framelet are measured in a Mann-monocomparator and recorded on punch cards. The aerial triangulation is carried out analytically. A preprocessor reduces the data of each framelet in scale and affinity according to edge-data measurements. All framelets are then referred to the common interior orientation system of the photograph, and lens distortion corrections are applied. The main part of analytical aerial triangulation consists of a general computer programme developed by Raytheon/Autometric under contract to the Geodetic Intelligence and Mapping Research and Development Agency of the U.S. Army. It is based on a Herget formulation. Instead of proceeding with the computations model by model and using a subsequent strip or block adjustment, the programme uses the conditions of all intersecting rays and of all control points simultaneously for an adjustment of all photographs in a space rectangular system in one run. The programme is extremely versatile and has few limitations: up to 100 photographs of arbitrary camera positions and directions with an almost arbitrary number of transfer points and control points may be adjusted simultaneously. Control points, air stations and exposure directions may be introduced as known values with weights varying from 0 to ∞ . To process a block of 100 ordinary aerial photographs simultaneously requires less than an hour of computing time on the Univac 1108 computer. To process the triangulation of one Lunar Orbiter site of 16 exposure stations with over 1000 transfer points, each transferred up to 4 times takes only about 30 minutes.

Aerial triangulation residuals between framelets resulted in residuals of $\pm 100 \mu$ for the transfer points, which were intersected by up to 7 rays. Their simultaneous use is apt to improve the accuracy of determination of 2.5 times. Lunar Orbiter mission 3 photography possesses a pre-exposed film grid. Its use will permit a further reduction in systematic errors.

Mapping from Medium Resolution Photographs by Stereomat-Wild B8.

The aerial triangulation provides the control for subsequent mapping of each framelet. For the sake of convenience, however, individual framelets on 35mm. film are not used, but reductions of the reassembled photograph are used on glass diapositives, which have a scale of twice that of the spacecraft medium resolution photo to fit the ranges of the Wild B8. The Stereomat B-8, Model V, incorporates the capability of automatic relative orientation, automatic profile scanning for orthophoto-production and of automatic contouring. The various modes of operation can be selected on a control panel.

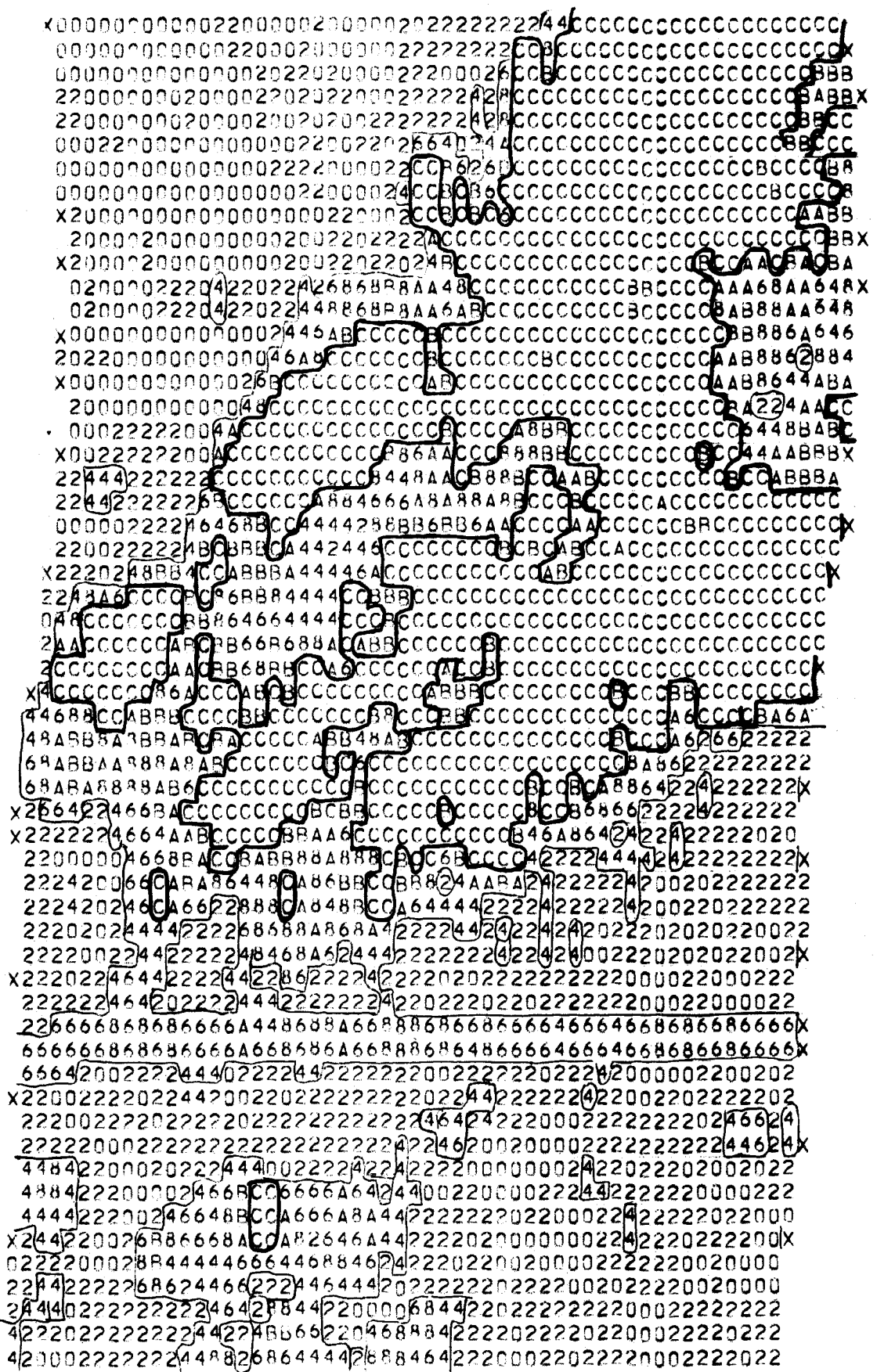

FIGURE 1.7 Computer output: slope chart. Symbolic representation of maximum slope.

Any analog stereoplotter, including the automated Stereomat B-8, is unsuitable for direct plotting from Lunar Orbiter photographs, which due to individual framelet distortions, appear like a row of warped stairs as seen from the top. The Stereomat B-8 possesses an Autotrol digitizing unit, which permits recording of X, Y, Z information of points or at certain increments during profiling, onto magnetic tape. Additional codes may be brought on tape by a keyboard, which also controls the digitizing operations. This digitizing unit can be utilized to record a digital terrain model on tape.

After automatic relative orientation, which can be performed in a few minutes, the area to be digitized is outlined on the plotting table with conductive tape. The profiling mode is started and the digitizing unit records a sequence of Y, X, Z co-ordinates, usually at 2mm. intervals, for the entire model. This can usually be accomplished in less than an hour.

Thereafter the co-ordinates are recorded for each framelet control point in the model, used in the aerial triangulation procedure. Its adjusted height is entered on the keyboard. The framelet edges are also recorded. The tape is then processed on a general purpose computer, such as the Univac 1108. From the measured and adjusted heights for all control point configurations it forms correction polynomials of the form:

$$Z = a_0 + a_1X + a_2Y + a_3XY$$

Such a polynomial is valid for all control point configurations up to the respective framelet edges. When a point of the digitized terrain model is called for further processing, its height is corrected according to its X, Y position by the corresponding polynomial.

The output is given in four forms:

1. an adjusted X - Z profile is printed out on 35mm. film for future reference; it may be enlarged, if needed by microfilm equipment.
2. the adjusted heights can be printed out by specific symbols, signifying that the point lies in a particular elevation zone. Testing the X - Y position of the point, it is printed in a corresponding printer position within the limitations of the output printer used.

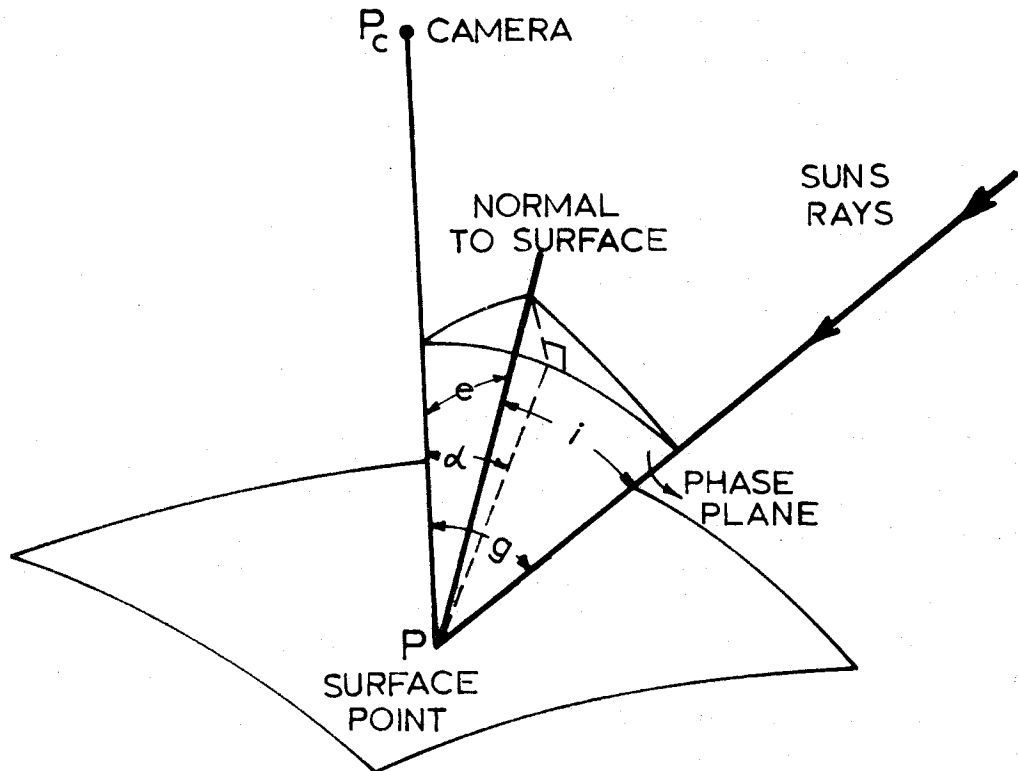

g =PHASE ANGLE
 i =INCIDENCE ANGLE
 e =EMISION ANGLE
 α =PROJECTION OF e ONTO
 PHASE PLANE

FIG. 1.8 REFLECTANCE ANGLES.

3. since the prime objective of the Lunar Orbiter Mission is to find areas with minimum slope conditions, a slope chart can be prepared in a similar manner. An alphanumeric symbol constitutes a maximum slope for a particular point. The maximum slope has been computed from the slopes to the 8 closest adjoining points. (Figure 1.7)
4. The computed slope information may be used for a summary of the slope statistics; the number of individual slopes in a certain category is counted up in a histogram manner.

It is likewise possible to produce altitude and slope charts by the digital contouring technique.

The mapping procedures outlined are used for mapping the radar approaches of selected landing ellipses, and for a rough selection of landing ellipse areas.

Photometric Evaluation of High Resolution Photographs. The final selection of roughly selected landing site areas is made using high resolution photographs. Due to their overlap of only 5% they cannot be used for stereo-evaluations. Their evaluation is carried out by photometric techniques. (4) These are based on the photometric relations between solar illumination intensity L_0 , the normal albedo of the surface ρ_0 and the observed surface brightness B . Depending on the viewing geometry the brightness becomes a function of the phase angle g (the angle between observer and sun subtended at the surface point) and the projection of the emission angle e (the angle between observer and surface normal) onto the phase plane, forming the angle α . (Figure 1.8)

$$B = \rho_0 \cdot L_0 \cdot \phi$$

$$\phi = f(g, \alpha)$$

The function relating the albedo-illumination product to brightness in dependence of phase angle and emission angle projection is referred to as the photometric function.

The lunar photometric function has been investigated by various astronomers measuring light intensities received for the same targets at varying positions of the sun. (Figure 1.9) Brightness can be related to

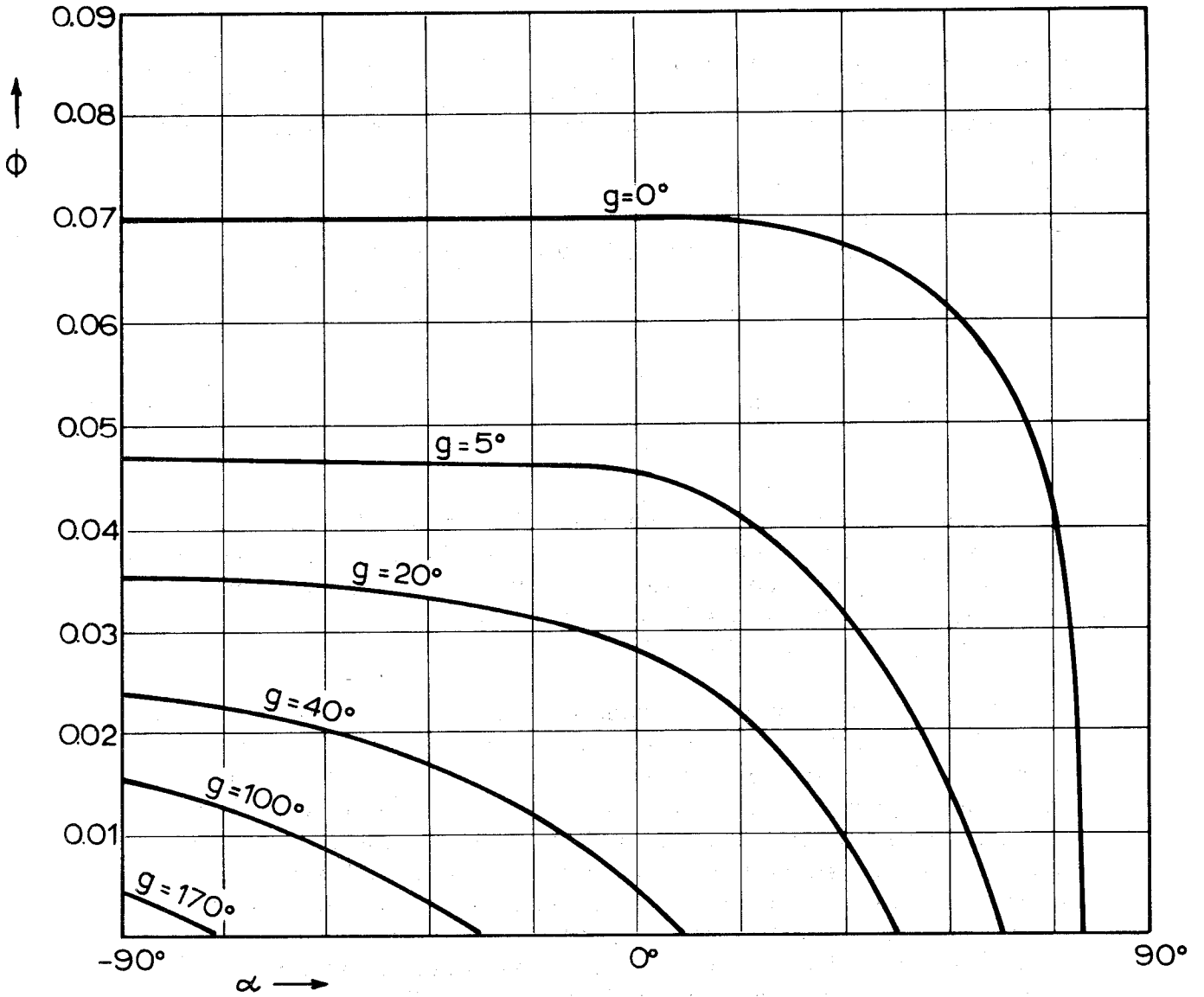

FIG. 1.9 PHOTOMETRIC FUNCTION CURVE $\phi = f(g, \alpha)$

exposure E_x on the photographic emulsion using a number of photographic constants, such as exposure time T , transmission coefficient of the lens τ , principal distance f , and lens diameter d_L :

$$E_x = \frac{\pi}{4} \frac{B \cdot T \cdot \tau}{\left(\frac{f}{d_L}\right)^2}$$

The density - exposure relation on a photographic emulsion is given by a Hunter - Driffield curve, normally referred to as a $d/\log E$ curve. The relation can mathematically be expressed in terms of an error function curve:

$$D = \frac{D_0}{2} \left[1 + \operatorname{erf}\left(X + \ln \frac{E_x - E_0}{E_g - E_0}\right) \right] ;$$

$$\operatorname{erf} Y = \frac{1}{\sqrt{\pi}} \int_{-\infty}^Y e^{-y^2} dy ;$$

The curve is characterized by a number of constants X , D_0 , E_0 and E_g ; these are usually dependent on the sensitivity of the emulsion and the γ or the $d/\log E$ slope of the development. In case of Lunar Orbiter photography further complications are introduced by transmitting and reconstructing the video-information.

To find a relationship between density and exposure for Orbiter photography the edge-data carry a pre-exposed calibrated gray-wedge in X direction. To eliminate scanner intensity variation effects in Y direction, a pre-exposed gray-wedge in form of the so called "Goldstone pattern" has been included at the beginning and at the end of the film. It permits preparation of a mask by which the densities measured in a microdensitometer may be reduced. The pre-exposed gray-wedges also make absolute calibrations of the microdensitometer unnecessary. After the known gray-wedges have been measured, absolute exposures can be computationally related to measured densities. The exposures are related to brightness by aid of the camera constants. For a known or assumed albedo-illumination product the photometric function can be calculated from photometric densities.

Knowing the relation between lunar photometric function, phase angle and emission angle projection the calculated photometric function may be used to calculate the only unknown in the relation, the emission angle projection onto the phase plane. The phase angle, involving the directions between sun, surface point and the camera can be calculated from known astronomical data for the time of photography, but the emission angle depends upon the direction of the surface normal, which is influenced by the slope of the terrain. The emission angle projection into the phase plane, in particular, is influenced by the slope in phase plane direction. It therefore becomes possible to calculate the slope component in the phase plane from density variations along a phase-plane profile.

A computer programme was first developed to construct an overlay for Lunar Orbiter high resolution photographs which shows a grid of phase plane directions and of constant phase angles for a particular photograph taken at a particular exposure station, with a specific solar position and a particular camera orientation. The computer output was fed to a Gerber X - Y Plotter, which plotted the overlay automatically.

This information permitted the transfer of the phase plane directions to the high resolution framelets on 35mm. film. The pricked profile starting and end points were related to the control system by means of a telecordex viewer, which provided the transformation constants required for the data reduction. Then a Joyce-Loebl microdensitometer with a digital recording possibility was used to obtain a densitometric record along each profile, and along subsequent parallel profiles on magnetic tape.

At the same time a graphical densitometric record in form of a drop-line density chart was provided by the instrument. The microdensitometer tape was then entered together with the required geometrical input data into the computer.

The photometric reduction programme requires the following input:

- (a) camera position (selenographic latitude, longitude, height and lunar radius);
- (b) solar position (selenographic latitude and longitude or its astronomical equivalent);
- (c) camera attitude (tilt and its azimuth);
- (d) exposure time;
- (e) camera calibration data (focal length, lens transmission factor, density mask);

- (f) transformation elements (to transfer densitometer co-ordinates to control);
- (g) gray scale calibration data;
- (h) illumination-albedo product;
- (i) logical constants (which programme options are to be followed);
- (j) photometric function values (expressed as a number of polynomials).

The programme proceeds to fit an error function curve or, as other options, a polynomial and a second order interpolation curve to given gray-scale relations. Then the photometric function is calculated for each point. The densitometer point co-ordinates are transformed into selenographic positions by aid of co-ordinate transformations, rectification and projection. Camera position, solar position and point co-ordinates are used to derive the phase angle g and an emission angle projection α' for the assumption of a plane terrain. For a known photometric function ϕ and a known phase angle g the corresponding emission angle projection α is calculated. The slope $\Delta\alpha$ is the difference between α' and α .

For a known densitometer profiling increment the slopes may be accumulated into elevation profiles. Their output may be in graphical profile form, produced by the computer, or in any other form, as described for the digital stereomat output, as altitude or as slope chart.

The photometric slope determination has the following drawbacks:

1. Slopes can only be calculated for the phase plane direction. Cross slopes cannot be determined except when the same site is covered by another mission with different illumination direction.
2. It assumes the knowledge of a photometric function. There are presently three standard photometric functions in use, which all give different results. (Figure 1.10) When adjusted to controlled end points the height variation is less serious, however. (Figure 1.11) It should be remembered, that the prime requirement in lunar mapping is the determination of slope, which is less affected than the height variation.
3. An incorrectly assumed albedo-illuminance product deforms the absolute slopes considerably. (Figure 1.12)

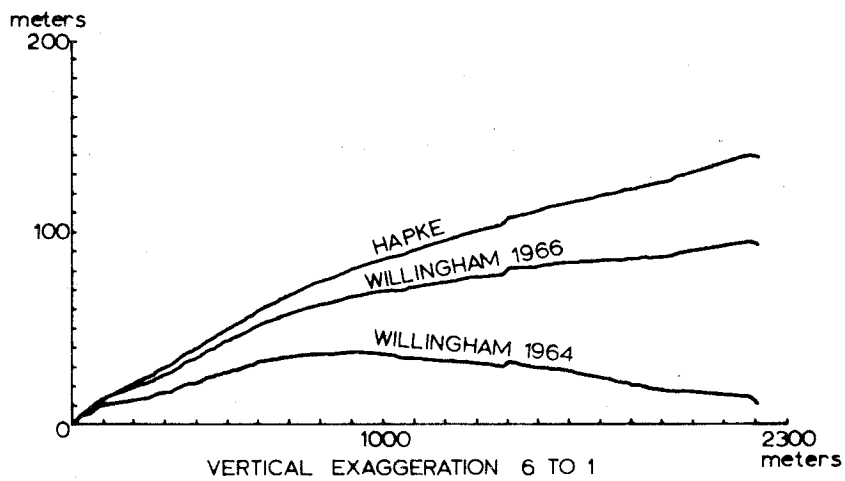

FIG. 1.10 PROFILES COMPUTED USING THREE DIFFERENT PHOTOMETRIC FUNCTIONS.

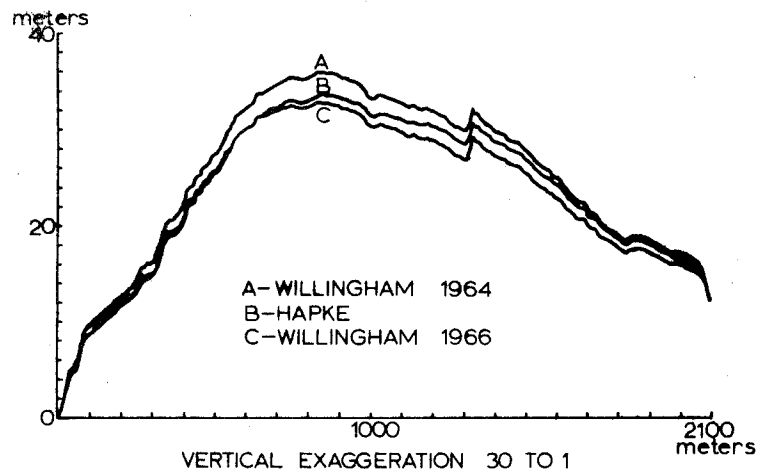

FIG. 1.11 ADJUSTED PROFILE COMPUTED USING THREE DIFFERENT PHOTOMETRIC FUNCTIONS.

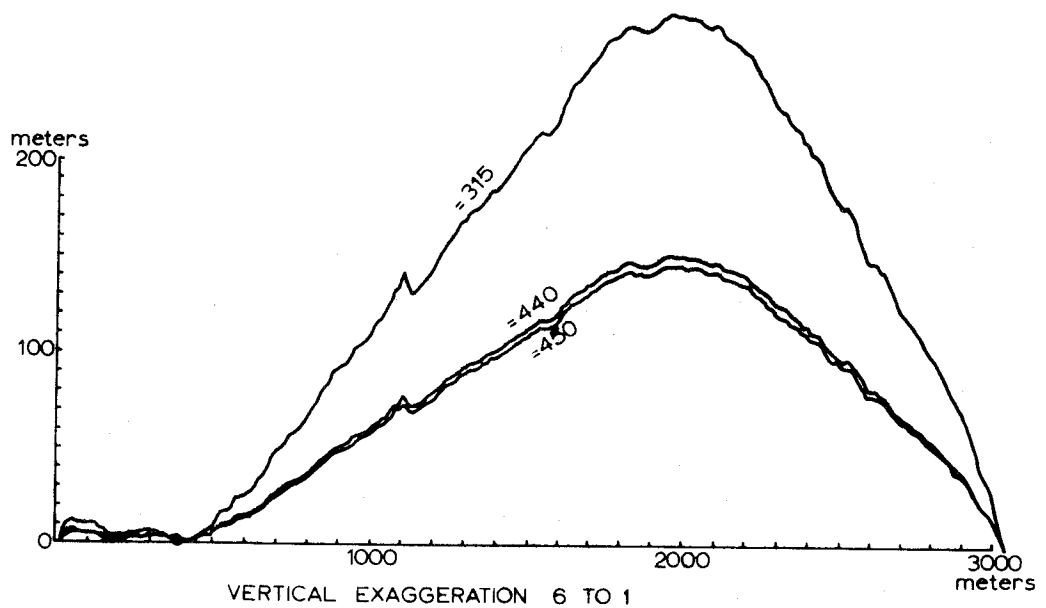

FIG. 1.12 PROFILE VARIATION CAUSED BY CHANGES IN RELATIVE ALBEDO-ILLUMINANCE PRODUCT VALUES.

It was therefore felt that a knowledge about photometric function and albedo-illumination product had to be gained directly out of Lunar Orbiter Photography. Considering that moderate resolution photography permitted a stereoscopic determination of slopes in phase plane direction, such slopes could be determined in the Wild B-8 for various cross profiles at constant phase angles.

The photometric computer programme was slightly modified to permit the input of measured slope values and to adjust the photometric function for a constant phase angle in dependence on the varying slope angle in form of a polynomial. Such a local photometric function incorporated a more properly determined albedo-illumination constant. The polynomial could now be used with high resolution photography to obtain a slope result estimated to be within $\pm 3^{\circ}$.

The described photometric reduction procedure is very slow since it requires the handling of individual framelet film strips. Another procedure has therefore been devised to handle the photometric reduction more efficiently. It makes direct use of the recorded video signals on film, rather than of reconstructed photographs. The analog video signals of a framelet portion are digitized and fed into the Univac 1108 computer in real time. A cathode ray-tube permits the monitoring and polaroid photography of the digital reconstruction. A computer programme along similar lines as previously described is used for the photometric reduction. The computer produces a digital slope chart printout and a digital contour plot. The advantage of the system is twofold:

1. It permits to evaluate several framelets and pictures in continuous succession.
2. Outside of a graphical record it provides statistical data about the slope distribution.

4. Conclusion

It can be concluded that a manned landing on the moon relies heavily on the information provided by mapping techniques. The mapping requirements are completely unconventional. Methods, instrumentation and even the acquisition of photography are novel; no established classical evaluation techniques exist. The effort is multi-professional, since classical earth-oriented mapping experts are not able to solve all problems

on their own in the short time available. Electronics experts, physicists with various specializations, are involved at par with photogrammetrists and geodesists (or selenodesists). It is a challenge in which the photogrammetrist has to prove his capabilities, with the requirements varying from day to day.

References:

- (1) G. Schrutka-Rechtenstamm, Neureduktion der 150 Mondpunkte der Breslauer Messungen von J. Franz . Sitzungsberichte der Osterreichischen Akademie der Wissenschaften, Mathem. - naturw. Klasse, Abteilung II, Springer Verlag, Wien 1958.
- (2) J. van Diggelen, A Photometric Investigation of the Slopes and the Heights of the Ranges of Hills in the Maria of the Moon . Bulletin of the Astronomical Institutes of the Netherlands, Vol. XI, No. 423, July 1951.
- (3) L.D. Bowles, D.L. Light, R.W. Harpe, Experimental Mapping from Ranger Photography . Army Map Service Technical Report No. 59.
- (4) T. Rindfleisch, Photometric Method for Lunar Topography . Photogrammetric Engineering, March 1966, pp. 262-276.

ANALYTICAL AERIAL TRIANGULATION IN TASMANIA

by

M.T. Noonan

1. Introduction

Analytical photogrammetry commenced in Tasmania in 1946 with the purchase of a Cambridge stereocomparator. Early methods of aerial triangulation were based on formulae developed by Professor Earl Church, but the results obtained were suitable for mapping only relatively flat terrain.

In 1954, the Department was faced with the problem of mapping large areas of the rugged Western half of Tasmania, and because of the mountainous nature of this country a new approach was required. The Ordnance Survey stereocomparator technique (1) was, therefore, adopted. Although this technique was developed by the Ordnance Survey primarily for the provision of horizontal control, only minor modifications were necessary to enable the provision of vertical control also. Further modifications were necessary to reduce the amount of computation involved and make this method an economic proposition using desk calculators.

With the purchase of a Hilger and Watts stereocomparator in 1963, and the installation of an Elliott 503 computer at the University of Tasmania the following year, changes were again necessary, and the current method of analytical aerial triangulation was, therefore, introduced.

2. Photography

All the photography used by the Department for analytical triangulation on the Hilger and Watts stereocomparator has been taken with a Wild R.C.8 camera. The picture format is 18 x 18cm. with a focal length of 115mm. The fiducial marks have been modified by the addition of 0.1mm. diameter holes placed at the intersection of the arms of the marks so that they can be accurately measured in the stereocomparator.

Kodak Plus X Estar Base film has been used on all projects to date. This is processed in the Department's own photographic section.

3. Diapositive Preparation

Natural points of detail are selected for pass points and tie points whenever possible. Otherwise pricked points, made by a pricking and circling attachment on a modified Cambridge stereocomparator, have to be used. All points are circled by accurately scribed concentric circles and, in the case of control points, this can obviate the reference to sketches by the stereocomparator observer.

Pairs of points are required in each of the six normal orientation positions. Of these, the two points in the centre of each diapositive are marked but only one of each pair of wing points. The other is left to the discretion of the operator to choose while observing the overlap in the stereocomparator. The four marked points on each diapositive are used for the connection of adjacent overlaps.

4. Stereocomparator Observations

The Hilger and Watts stereocomparator is a non-transistorized model, incorporating both typewritten and punched tape output. Annular floating marks with an internal diameter of 0.06mm. and a thickness of 0.015mm. are used in conjunction with 12x binoculars. Each point is observed only once and 'Y' parallax is eliminated by using dove prisms rotated to 90° either side of the normal position.

The observations made on each point are preceded by identification data of up to 12 digits pre-set on the console of the stereocomparator.

The point numbering code used is identical to the 10 digit reference system adopted as standard by the National Mapping Council of Australia (2). The additional 2 digits recorded are used to identify the observer.

Control and tie points are sometimes located in areas where the accurate elimination of Y parallax with the dove prisms is impossible. In order that these points should not be included in the relative orientation they must be the last ones read on the overlap and the total number of such points must be set in the special terminating data recorded at the end of each overlap.

The stereocomparator operator is presented with exact and detailed descriptions of the observing procedures. These procedures must be strictly adhered to as, otherwise, a mistake detected after a point has been accepted is often impossible to correct on the paper tape. This mistake could prevent the correct solution of the relative orientation or the connection between overlaps and, in such cases, the whole overlap would have to be re-observed. This, of course, is not a problem with punched card recording as a card can easily be replaced should a mistake be discovered.

5. Computational Procedures

The steps involved in the computational procedure are shown in flow diagram form in Figure 2.1. The heavily outlined portion of the diagram shows the steps involved if the computations proceed in the ideal way. If something is not in order then the course followed is indicated by the lightly outlined portion of the diagram.

The computations are divided into various stages, each stage being checked for errors before further computation is undertaken. The three stages for which computer programmes have been developed are:

- (1) Stereogram Solution.
- (2) Strip Formation.
- (3) Strip Adjustment.

Stereogram Solution. This programme carries out the following steps for each overlap:

COMPUTATIONAL PROCEDURE

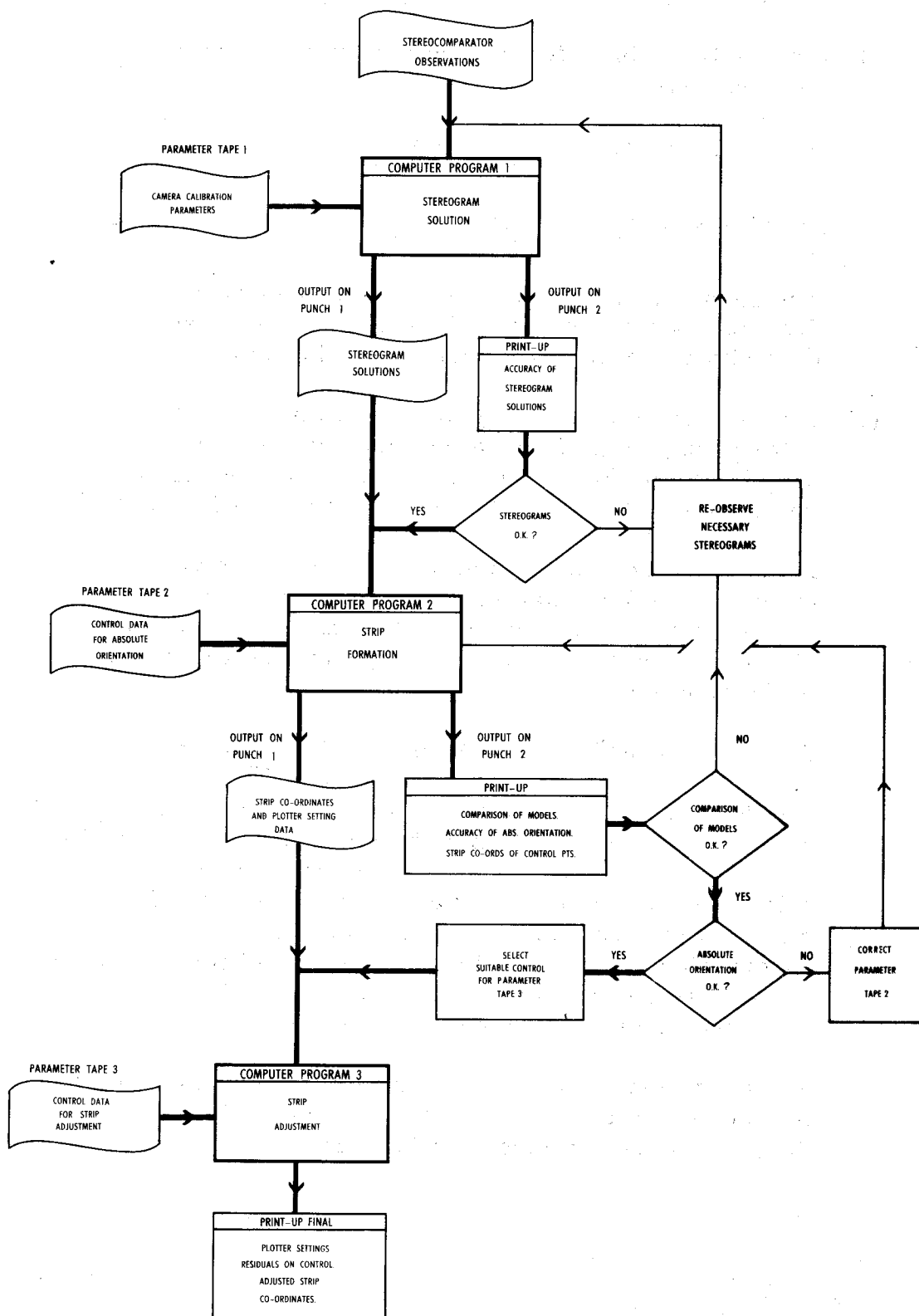

FIGURE 2.1

CONTROL FOR MAPPING

- (1) Converts the stereocomparator observations into photo co-ordinates with origin at the principal point.
- (2) Applies film distortion corrections to every point using the equations

$$dx = a_1x + a_2y + a_3xy + a_4 \quad 1.$$

$$dy = a_5x + a_6y + a_7xy + a_8 \quad 2.$$

The parameters a_1, a_2 etc., are derived from the differences between the calibrated and measured co-ordinates of the four corner fiducial marks (3).

- (3) Corrects each point for symmetric radial lens distortion. If the flying height is greater than 5000 feet, corrections are also made for earth curvature and atmospheric refraction, using formulae derived by Leyonhufvud (4).

Before commencing a particular project, the values of the combined lens distortion, earth curvature and atmospheric refraction are plotted against the radial distance. From this curve, the parameters a, b, c, d in the equation

$$1 - \Delta r/r = ar^6 + br^4 + cr^2 + d \quad 3.$$

are derived by least squares from suitable points on the curve. Δr is the combined distortion and r the radial distance. The four parameters, together with the calibrated values of the co-ordinates of the four fiducial marks, are input prior to the stereocomparator observations tape. Multiplication of the observed image co-ordinates of a point by the right hand side of equation 3. gives the corrected co-ordinates.

No correction is made for asymmetric lens distortion as the mean distortion curve differs from the four half-diagonal curves by less than 0.003mm.

- (4) Determines the relative orientation by a completely general least squares method using every suitable point no matter what its position in the overlap. The solution is an iterative process developed by Professor E.H. Thompson (5) and based on the correspondence condition that the rays from a ground point to the two camera stations are coplanar with the air base.

When the size of the corrections to the five independent unknowns in the solution falls below a set tolerance, the final iteration is carried out and the solution terminated. The model co-ordinates of all marked points, including those designated as unsuitable for relative orientation, are then computed.

- (5) Calculates the relative scale factor relating this stereogram to its predecessor. Normally relative scale factors for the 4 pass points and any suitable control or tie points are determined and the mean accepted. However, scale factors may be calculated for all points occurring in the triple overlap common to adjacent stereograms.

The output from this programme consists of two result tapes. One tape contains all the data for the subsequent strip formation, and the other is a check tape which is immediately printed up. A line printer will be available in the near future; but, at present, all printed results are done on a flexowriter. On this check tape appears the following information:

- (1) The corrected principal distances in the X and Y directions.
- (2) The residual film distortion on the four fiducial marks after a least squares linear transformation to the calibrated positions.
- (3) The residual scale differences on every connection point between overlaps.
- (4) The standard error of Y parallax.
- (5) The residual Y parallax of every point measured.

This information is then analysed to determine whether any overlap should be re-observed. The analysis requires a skilled person with a complete knowledge of the computational process. He has to make the correct decision as to how a mistake can be rectified: whether by punching additional information on the original tape, or by re-observing the faulty overlap. Normally, a point with a residual Y parallax greater than 0.010mm. or a relative scale factor differing from the mean by more than 0.025% is carefully investigated. Only about 2% of the total number of overlaps observed to date have been re-observed.

Strip Formation. This programme carries out the following steps in forming the strip:

- (1) Takes the result tape from the stereogram solution programme, together with a similar tape for any re-observed overlaps, and produces strip co-ordinates by connecting all the stereograms together. The resulting strip co-ordinates are at the same scale and in the same co-ordinate system as the first stereogram of the strip.
- (2) Scales and levels the strip with respect to the ground by a linear three dimensional transformation. A maximum of four ground control points, two situated at either end of the strip, may be used for calculating the scale. When more than two controls are used, the mean scale is accepted.

Four vertical control points, situated near the corners of the strip, are used to calculate two of the three parameters required for the construction of an orthogonal matrix representing a rotation in three dimensional space. The third parameter does not affect the levelling of the strip and is set to zero. The application of this matrix to the strip levels it, leaving equal and opposite residuals in height at adjacent corners. The Ordnance Survey formulae for strip formation (1) were used in this programme.

The output from this programme also consists of two result tapes. One tape contains all the necessary data for subsequent processing in the strip adjustment programme while the other is again a check tape

containing the following information:

- (1) The differences between the two sets of model co-ordinates for all points common to two adjacent stereograms.
- (2) The residual scale differences on every connection point between re-observed and adjacent original stereograms.
- (3) The difference in the two determinations of the strip scale if more than two ground control points are used.
- (4) The residual in height on the four vertical control points.
- (5) The scaled and levelled strip co-ordinates of all ground control points.

This check tape is printed up and the results examined for errors. The control points especially are carefully examined for misidentification and incorrect ground co-ordinates by means of a linear transformation.

Strip Adjustment. This programme adjusts the strip as follows:

- (1) Transforms the strip in position by a least squares second degree conformal transformation on all suitable horizontal control points.

The equations used are:

$$x' = a_1x - a_2y + a_3(x^2 - y^2) - 2a_4xy + a_5 \quad 4.$$

$$y' = a_2x + a_1y + a_4(x^2 - y^2) + 2a_3xy + a_6 \quad 5.$$

where x' , y' are the adjusted strip co-ordinates.

- (2) Transforms the strip in height by a least squares second degree transformation on all suitable vertical control points using the equation:

$$z' = a_7x^2 + a_8x + a_9xy + a_{10}y + a_{11} + z \quad 6.$$

where z' is the adjusted height.

- (3) Calculates the setting data for the plotting machines.

The output from this programme is a single tape containing the following information:

- (1) The setting data for each overlap.
- (2) The residuals in feet on all control points used in the adjustments.
- (3) The adjusted strip co-ordinates and heights of all points.

6. Block Triangulation

An average size block of photography flown for the production of the 1:31680 series of topographical maps covers some 1200 sq. miles. The blocks are controlled by three tie runs flown at right angles to the main body of cross runs. The tie runs are controlled by a pair of control points at each end of the strip and one in the middle. Extra single height control points are located on the tie runs and the first and last cross runs midway between the main control areas. Points transferred from the tie runs are used to control the cross runs. With this arrangement it is sufficient to mean the tie points between cross runs to obtain the necessary accuracy for standard mapping control.

Where originally all the photography for block triangulation on the Hilger and Watts stereocomparator was flown from 20,000 ft., the altitude has now been reduced to 12,000 ft. so that the scale of the photography is more suited to the requirements of all agencies using it. The average size block requires 11 cross runs of 25 overlaps and 3 tie runs of 20 overlaps for coverage from this altitude. From the results to date, it appears to make little difference to the final accuracy whether the photography is flown at 20,000 or 12,000 ft. above ground level.

7. Large Scale Projects

Large scale plans plotted from single strip photography constitute almost half of the stereoplotting produced by this Department. The strips are controlled by pairs of control points fixed in plan and height on every third overlap. This control has proved quite satisfactory

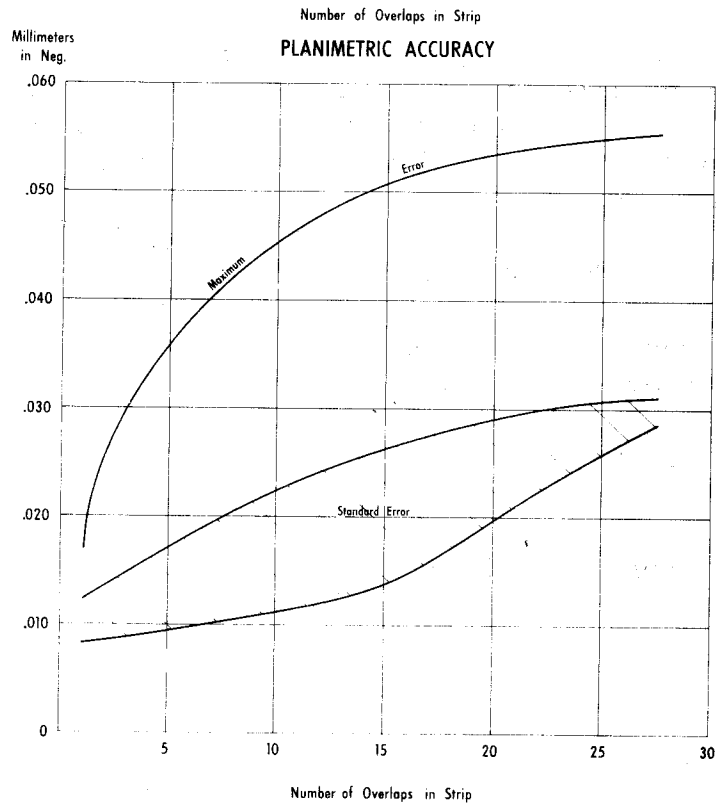
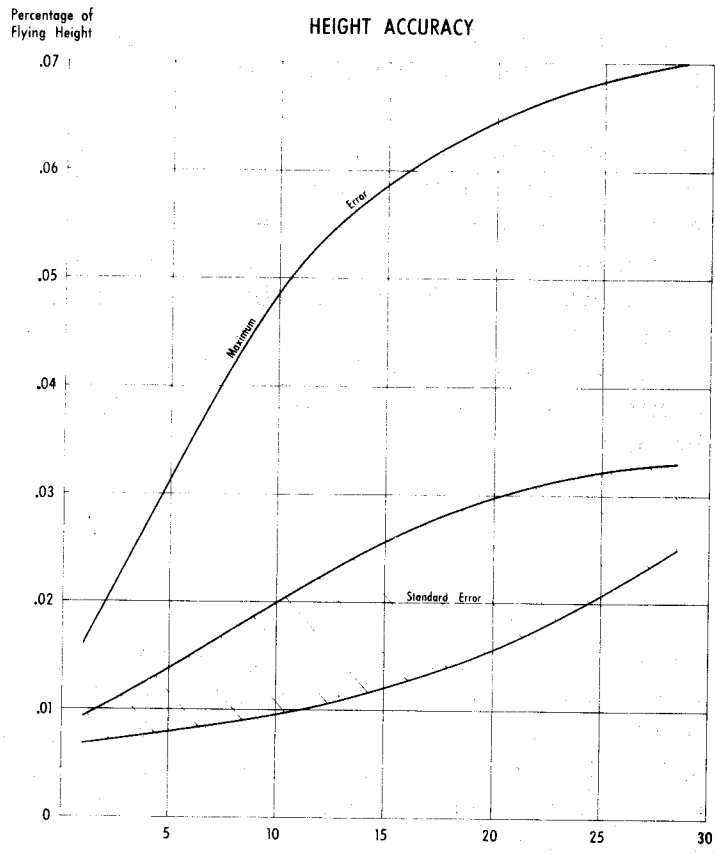

FIGURE 2.2

when plotting 5 foot contours at 1:2400 from photography flown at 5000 feet, or plotting 2 foot contours at 1:7200 from photography flown at 2400 feet.

Apart from the obvious saving in ground control, aerial triangulation has other advantages in large scale mapping. The plotting machines are supplied with easily identified pricked pass points in good positions in the four corners of each overlap and also near the principal point. (The latter are particularly useful when a big enlargement from photo to plan necessitates plotting the overlap in two halves). Control errors and identification problems are ironed out during triangulation and also a better fit is achieved between overlaps and a higher relative accuracy obtained for the plan.

8. Accuracy

Up to 40 check points per strip were used for the determination of standard errors and maximum errors obtained from 12 runs triangulated on the stereocomparator and shown in the graphs in Figure 2.2. The flying heights range from 2,400 feet to 20,000 feet and the forward overlaps are nominally 60%. All strips were adjusted separately in height and plan by second order curves using a pair of control points at each end and a pair in the middle of the strip.

Details of the relative accuracy obtained on the Hilger and Watts stereocomparator were published by the Department in 1964 (6) and a full report of the results obtained on an average size block flown from 20,000 feet was published in 1965 (7). The absolute accuracy obtained on this block was as follows:

Error in position on 25 check points:

Standard error	\pm 5 feet
Maximum error	8 feet

Error in height on 81 check points:

Standard error	\pm 4 feet
Maximum error	10 feet

References

- (1) D.W.G. Arthur. A Stereocomparator Technique for Aerial Triangulation. Ordnance Survey Professional Paper No. 20, H.M.S.O. 1955.
- (2) Technical Sub-committee Working Group. Standardised System of Photogrammetric Point Numbering Code. Proceedings of National Mapping Council of Australia, 22nd Meeting, Part 3A-Annexure M, 1963.
- (3) Lands and Surveys Department, Tasmania. Film Distortion in Non-Reseau Cameras. Proceedings of National Mapping Council of Australia, 21st Meeting, Part 3, 1962.
- (4) A. Leyonhufvud. On Photogrammetric Refraction. Photogrammetria, IX, 1952-1953, 3.
- (5) E.H. Thompson. A Rational Algebraic Formulation of the Problem of Relative Orientation, The Photogrammetric Record, Vol. III No. 14, 1959.
- (6) Lands and Surveys Department. Tasmania. Hilger and Watts Stereocomparator Results. Proceedings of National Mapping Council of Australia, 23rd Meeting, Part 3A-Annexure L, 1964.
- (7) Lands and Surveys Department, Tasmania. Report on Analytical Aerial Triangulation with Hilger and Watts Stereocomparator. Proceedings of National Mapping Council of Australia, 24th Meeting, Part 3-Annexure H, 1965.

AERO-TRIANGULATION TECHNIQUES IN NEW SOUTH WALES

by

A. Zvirgzdins

Abstract. Development of various aerial-triangulation methods in the Central Mapping Authority of the Department of Lands at New South Wales are described and some possibilities of further improvements and developments are indicated.

1. Introduction

In 1947 when a New South Wales Government Mapping Investigation Committee recommended the establishment of the Central Mapping Authority less than 10⁰/o of the 310,000 square miles of N.S.W. Territory was mapped.

A publication scale of 1:31,680 with 25 or 50 feet contour interval, depending on the topographical character of the terrain, was selected. The National Mapping Council's standards of map accuracy were adopted, which provide horizontal tolerances of 0.5mm. and half the contour interval for 90⁰/o of well defined test points. However, in practice any errors in excess of 0.5mm. or more than half a contour interval are investigated and rectified by field survey or photogrammetric methods. (1)

From two A5 Autographs, seven A6 Stereoplotters, one Kelsh plotter and a seven-projector Multiplex in 1952, the number of

photogrammetric instruments has increased to 22. At present the Photogrammetric Division of the Central Mapping Authority has one Stereocomparator with IBM card punch recording, one A5 Autograph, two A8 Stereoplotters one of which is equipped with an EK5 and an IBM card punch, three B8 stereoplotters, seven A6 Stereoplotters, one Stereometrograph, two PG2 Plotters and five PG2L stereoplotters. An increase of five more instruments has been indicated.

Since the establishment of the Central Mapping Authority some 22,000 square miles have been mapped and the progress at present is approximately 4,000 square miles in a year. Besides the standard mapping a large number of large-scale mapping projects are carried out for various Authorities every year.

2. Aero-triangulation in the early stages of the Central Mapping Authority

In the early stages of the Central Mapping Authority several different methods were used for extension of horizontal control.

Templates and stereo-templates were used for several areas. A5 autographs and A6 stereoplotters were used for single strip triangulation. The aerial triangulation observations were adjusted by Zarzycki's graphical methods and the heights observed in the triangulation on A6 stereoplotters were adjusted analytically by using the following polynomial

$$\Delta h = ax^2 + bx + cxy + d \quad 1.$$

The disposition of the control was as indicated in Figure 3.1.

As the first model was fully controlled the following polynomial could be used for the adjustment instead of 1.

$$\Delta h = ax^2 + bx + cxy \quad 2.$$

This polynomial has no control of non-linear changes in internal tilt of the strip and therefore control requirements for a single strip were adopted as indicated in Figure 3.2.

The observations were adjusted by Zarzycki's graphical method. In this case we have more control as it is required for the determination

of non-linear changes in lateral tilt and it provides some information about error development in a single strip. Often it was observed that the adjustment curves based on three cross-sections did cut through a fully controlled model as indicated in Figure 3.3, which shows a longitudinal section of a strip.

Assuming that a map area is covered by five runs there are 30 control points required to adjust the aerial triangulation by single runs. However, in the early stages of the standard mapping the aerial photographs were taken from approximately 16,000 feet above the ground and 6 to 8 runs were required to cover a map-sheet and therefore the actual control requirements were 42 to 58 points per sheet.

From the above example it is understandable that an attempt was made to find ways of reducing the control requirements of aerial triangulation adjustments. As a solution to this problem, cross or key runs were introduced and the control requirements were as indicated in Figure 3.4.

In such a way the control requirements were reduced to 36 points per map-sheet.

The key-runs were triangulated twice and control was derived for the triangulation of the longitudinal strips. It is clear from Figure 3.4 that partly the reduction of control requirements was achieved by increasing the volume of the aerial triangulation. In the triangulation of the longitudinal strips several points common to adjacent strips were observed, which only served the purpose of checking the agreement or disagreement between the runs.

It seems natural that possibilities of reducing control requirements still further and using common points to improve the quality of a map should be investigated.

3. Developing semi-graphical block adjustment methods

About 1957 two officers of the Department of Lands in N.S.W. started to develop methods of simultaneous adjustment of several aerial triangulation strips or "blocks" for planimetry and heights.

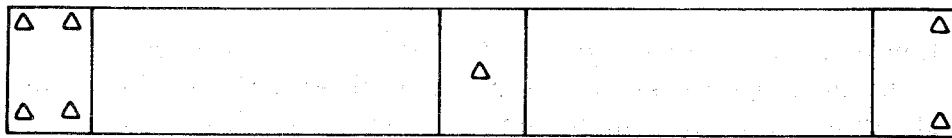

FIG. 3.1 POSITIONING OF CONTROL IN STRIP

FIG. 3.2 POSITION OF CONTROL IN STRIP.
NON-LINEAR CHANGES OF TILT
CONTROLLED.

FIG. 3.3 LONGITUDINAL SECTION OF STRIP.

FIG. 3.4 REDUCTION IN CONTROL REQUIRED
THROUGH USE OF CROSS-STRIPS.

The author of this paper suggested the use of the available control at an early stage by adjusting a strip using the derived values of common points for a preliminary adjustment of the adjacent runs (2). The polynomial used for the adjustment is as follows:-

$$\Delta x_i = a_0 + a_1 x_i + a_2 x_i^2 - b_1 y_i - 2b_2 x_i y_i$$

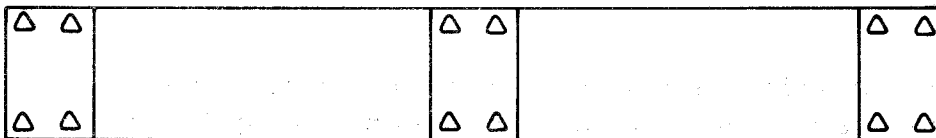
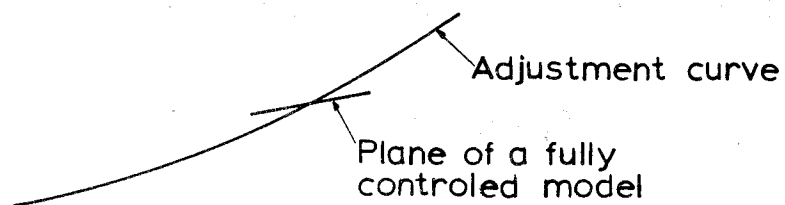
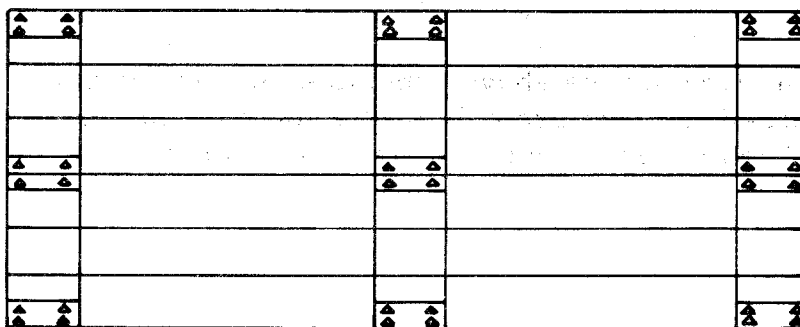
$$\Delta y_i = b_0 + a_1 y_i + 2a_2 x_i y_i + b_1 x_i + b_2 x_i^2$$

3.

Experiments indicated that the required corrections up to 1mm. at triangulation scale may be expected after joining five strips on one side of the run adjusted to three control points.

For the "final" adjustment to control a set of curves based on nine control points was used. The x and y co-ordinates were adjusted separately.

For the computational method of adjustment a set of nine equations of the following form was used:-

$$\Delta \bar{x}_i = A_1 x_i^2 y_i^2 + A_2 x_i^2 y_i + A_3 x_i y_i^2 + A_4 x_i^2 + A_5 y_i^2$$

$$+ A_6 x_i + A_7 y_i + A_8 x_i y_i + A_9$$

4.

and for the adjustment of the y co-ordinates

$$\Delta \bar{y}_i = B_1 x_i^2 y_i^2 + B_2 x_i^2 y_i + B_3 x_i y_i^2 + B_4 x_i^2 + B_5 y_i^2$$

$$+ B_6 x_i + B_7 y_i + B_8 x_i y_i + B_9$$

5.

At the same time as the above experiments were carried out S. Bervoets proposed to make use only of the common points between adjacent runs to form a "block" independent of any control (3).

The basic formula is the same as 3., but to be able to compute the parameters, sets of equations of the following form are used:-

$$\begin{array}{rcl}
 a_1 - a_2 & & = \alpha_{1-2} \\
 & a_2 - a_3 & = \alpha_{2-3} \\
 & \dots & \\
 & a_{n-1} - a_n & = \alpha_{(n-1)-n} \\
 a_1 + a_2 + a_3 + \dots + a_n & & = 0
 \end{array}
 \tag{6.}$$

The introduction of the last equation in 6. enables the system to be solved. This method, in general, reduces the deformation of the separate runs and the block itself too. There is no attempt to find the true co-efficients for each run.

The adjustment to control is by sets of curves or by using expressions 4. and 5. for computational methods.

This method has been adopted by the Department and it has been programmed for Utecom and Honeywell 400 electronic computers (4), (5).

The minimum horizontal control for a block is nine points and their disposition is as shown in Figure 3.5.

4. Present techniques of aero-triangulation

Since the development of the triangulation techniques described in the previous section the volume of mapping by the Central Mapping Authority has increased greatly in both fields: standard and large scale mapping. The type of instruments used for the aerial triangulation has changed too.

Instead of the universal type instruments, the A8 for independent model triangulation and the stereocomparator for analytical triangulation are used now. In both cases each strip is formed on an arbitrary scale and azimuth and therefore the method of adjustment described above

cannot be used directly in its original form.

For the formation of a strip from the independently observed models in an A8 E.H. Thompson's method is used. (6)

At the time when the selection of the method was made the independent model triangulation was developed for manual computation and little advantage was seen between Thompson's and Schut's method of joining the models together. The fact that it is not necessary to find the scale factor before the rotation elements can be computed was considered as a slight advantage in Thompson's method.

Later on, after a closer study it was revealed that in Thompson's method it is not advisable to use points near the principal point for the connection of models, because the denominator in the formulae 7. to compute the stereographic co-ordinates tends to approach zero.

$$x_i = \frac{X_i}{\sqrt{X_i^2 + Y_i^2 + Z_i^2} - Z_i} \quad 7.$$

$$y_i = \frac{Y_i}{\sqrt{X_i^2 + Y_i^2 + Z_i^2} - Z_i}$$

where x_i and y_i are the observed co-ordinates of the pass points reduced to the right hand projection centre as origin, which for the points near the principal point tends towards zero and therefore the above expression 7. for these points approaches the following form:-

$$x_i = \frac{X_i}{\sqrt{Z_i^2} - Z_i} \quad 8.$$

$$y_i = \frac{Y_i}{\sqrt{Z_i^2} - Z_i}$$

Several commercial photogrammetric mapping organisations in N.S.W. are using Schut's formula, in which this restriction does not exist.

For the analytical triangulation in the Department a Hilger and Watt stereocomparator is being used. The observed picture co-ordinates are corrected for film shrinkage and lens distortions, and the effects of earth curvature and atmospheric refraction are removed before a model is formed.

The film shrinkage correction is applied by a co-linear transformation

$$\frac{A_1 x_i + B_1 y_i + C_1}{A_3 x_i + B_3 y_i + 1} = \bar{x}_i \quad 9.$$

$$\frac{A_2 x_i + B_2 y_i + C_1}{A_3 x_i + B_3 y_i + 1} = \bar{y}_i$$

where x_i and y_i are the observed picture co-ordinates. The parameters A_1 , A_2 , A_3 , B_1 , B_2 and B_3 are computed by substituting the observed co-ordinates and the calibrated values of the fiducial marks into 9. This transformation makes the observed values of all four fiducial marks agree with the calibrated co-ordinates.

The lens distortion correction presented a problem due to the assymetry of the distortion along the four semi-diagonals. It was found that by applying a transformation to the lens distortion, similar to that used to correct the film shrinkage, a mean distortion curve could be found which agreed much better with the distortion curves along each semi-diagonal than if the original values were used for the mean curve. The correction for the lens distortion is expressed as a third-order function of the radial distance from the principal point.

Several formulae for computing the effect of earth curvature were studied and it was found that the difference between H. Barrow's formula

$$S = Hw \left[1 + \frac{w}{2} \Delta p + \frac{w^2}{6} (1 + 3w^2) \Delta p^2 + \frac{w^4}{8} (3 + 5w^2) \Delta p^3 + \frac{w^4}{40} (3 + 30w^2 + 35w^4) \Delta p^4 \right] - Hw(1 + w^2) C_1$$

$$\begin{aligned}
 & - Hw^1 (1 + w^2) \left[(1 + 3w^2) C_1 \Delta p - (2 + 3w^2) C_2 \Delta p \right. \\
 & \left. + \frac{3}{2} w^2 (3 + 5w^2) C_1 \Delta p^2 - \left\{ 2 + 15w^2(1 + w^2) \right\} C_2 \Delta p^2 \right]
 \end{aligned} \tag{10}$$

and Schut's formula (7)

$$\Delta t = \frac{t^3}{3HR} \tag{11}$$

is negligible up to distances of 17km. and photographing heights up to 10km. and the latter has been adopted.

The formula of Leyonhufvud (8)

$$P = 10^{-7} \frac{\operatorname{tg} Z}{\cos Z} (2803.11h - 134.629h^2 + 3.2966h^3) \text{ km} \tag{12}$$

was adopted for the computation of the effect of atmospheric refraction.

To be able to apply Bervoets' procedure for block adjustment it is necessary to obtain the separate strips of a block reasonably parallel to each other and on approximately the same scale. This is achieved by a three-dimensional linear transformation into the axis of flight system of each run followed by a linear transformation to join the strips at the beginning and the end. Finally the strips are joined into a block as suggested by Bervoets. (3), (4).

There have been also some developments in the field of height adjustment. To reduce the requirements for height control key-runs have been re-introduced. The selection of control requirements are as indicated in Figure 3.6.

From the 18 points nine have horizontal and vertical values and the other nine have height only. The saving in the field work is in the fact that 'satellite' points for height control only may be placed reasonably close to the points of full control. In the procedure the key runs are triangulated and a single row of points along a straight line near the centre line of the key is derived. These values are used for the adjustment of the lateral runs.

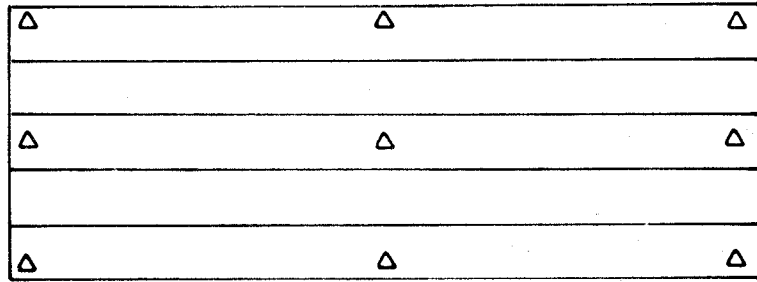

FIG. 3.5 SEMI-GRAPHICAL BLOCK ADJUSTMENT.
MINIMUM NUMBER OF HORIZONTAL
CONTROL POINTS.

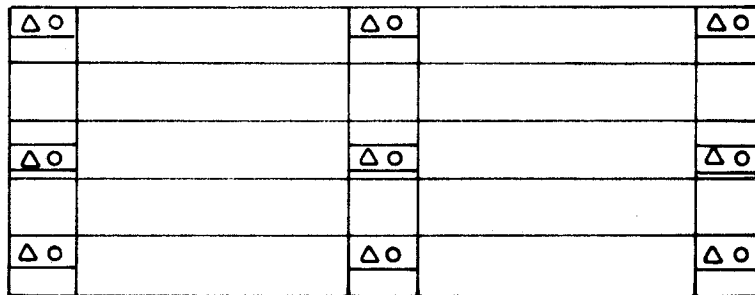

FIG. 3.6. HORIZONTAL AND VERTICAL CONTROL
REQUIREMENTS FOR AEROTRIANGULATION.

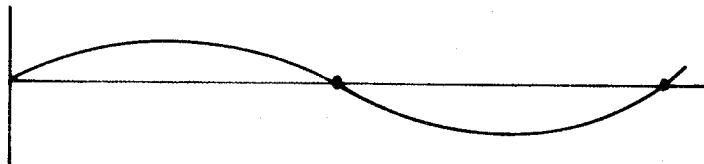

FIG. 3.7 COMMON FORM OF RESIDUAL HEIGHT
ERRORS.

5. Future developments

At this stage we have a system which produces acceptable results. However, some points need to be mentioned to indicate that further improvements are necessary.

In several cases it has been observed that the error development in a strip triangulation does not strictly follow a second-order curve. In the adjustment for position with the block method this is not so critical because the joining of the strips is based on best mean fit of all common points.

For the adjustment of heights only three banks of control are used and several times it has been observed that the differences on common points after the adjustment produces a curve similar to that in Figure 3.7.

However, there is some indication that in cases where these differences approach intolerable magnitude the mean value taken is very close to the true values. On the other hand if the differences are small the mean value still may not be as close to the true value as one would like it.

It seems that there could be two possibilities to restrain random error development into a local systematic error. One possibility would be by obtaining photography with 60% side lap, which would provide a possibility of developing a uniform surface by making use of best mean fit of common points. Such an experiment has been carried out in the Department by using grid plates (9). The result is promising.

A second possibility may be found in getting away from the formation of single strips and trying to straighten them out afterwards. Some such methods have been developed by using smaller units instead of strips.

The author has started an experiment along these lines. A strip is being formed as a preliminary measure to find by a second-order conformal transformation corrections which are applied to the single model co-ordinates (not to the mean values between adjacent models). It is expected that this procedure should introduce only negligibly small deformations in the original shapes of the models and maintain a very

close agreement on common points between models in a strip and also between adjacent runs. After this a simultaneous linear transformation applied to all models in a block should produce the final values of each model in a single solution. The corrections necessary to make the common points agree, will indicate the magnitude of the model deformation.

An objection to such an approach to solve a block adjustment is the great number of condition equations to be solved simultaneously. However, the co-efficient matrix contains more than 90% zeros and it should be considered as a challenge to programmers to be able to solve this problem on a medium-sized electronic computer. By using photography with 60% side-lap the solution may be made stronger and an adjustment for height too may be possible.

Acknowledgement

This paper has been prepared under the direction of the Surveyor General and the approval of the Under Secretary of the Department of Lands of New South Wales. Permission to make use of official records for publication is gratefully acknowledged.

References

- (1) H.S. Rassaby. Photogrammetry applied to Standard Topographic Mapping at 1:31,680 in New South Wales.
- (2) A. Zvirgzdins. An Experiment in Block Adjustment, Part 1. Cartography Vol. 3, No. 3, September, 1960.
- (3) S.G. Bervoets. Block Adjustment. Cartography, Vol. 2, No. 4, 1958.
- (4) S.G. Bervoets. Further thoughts on Analytical Adjustment including Analyses of Results. Cartography, Vol. 3, No. 3, 1960.
- (5) A. Zvirgzdins. Present Techniques and Modifications for Electronic Computing. Cartography, Vol. 3, No. 3, 1960.
- (6) E.H. Thompson. An exact linear solution of the problem of absolute orientation. Photogrammetric Record, XV, No. 4.

- (7) H. Schut. Computation of height deformation in models caused by distortion of the photogrammetric image. Canadian Surveyor, XIV, 1.
- (8) A. Leyonhufvud. On photogrammetric refraction. Photogrammetria, 1952/3, No. 3.
- (9) A. Zvirgzdins. An Experiment in Block Adjustment, Part 2. Cartography, Vol. 4, No. 3, 1962.

STEREOCOMPARATOR PROGRAMMES FOR THE H-400 COMPUTER

by

E. Chambers

Abstract: It is the intention of this paper to set out a brief but adequate outline of the programming procedures devised to process data obtained from the Hilger and Watts stereocomparator and their integration, without existing photogrammetric programmes. The author is a Cartographic Surveyor in the Research Division of the Central Mapping Authority, Department of Lands, N.S.W.

1. The Stereocomparator

The Hilger and Watts Stereocomparator equipped with an IBM 026 card punch is used for automatic registration of the co-ordinates of corresponding images on a stereo-pair of photographs. It is used with register glasses for non-reseau photography with a calibrated grid of 1cm. intersections.

Its basic use is in aero-triangulation, at photo-scales of approximately 1:58,000, for the intensification of photogrammetric control for plotting at 1:25,000 or 1:31,680 for standard mapping purposes. To a lesser extent it is used in the supply of control for project mapping at various larger scales. The necessity of a computer programme system to carry out the complete phase of analytical procedures from photo co-ordinates to final adjusted strip or block co-ordinates is obvious.

2. Existing Programmes

Prior to December 1963 this Department used a Block adjustment programme coded for UTECOM at the University of N.S.W. The introduction of a Honeywell-400 computer in September 1963 and the subsequent creation of an Automatic Data Processing Bureau in July 1966 within the State Public Service led to the recoding of this system and to the further programming of Photogrammetric problems. This Bureau now has four Honeywell computers at its command.

The Photogrammetric programmes have been coded in the Efficient Assembly System (E.A.S.Y.) for the Honeywell-400 Computer (H-400). Chief among these being the block adjustment system, fixed base 3-dimensional join system for single model observations, Helmert Transformation system and more recently the stereocomparator and strip adjustment systems.

3. The Honeywell-400 Computer

The H-400 is a medium range computer containing 4,096 words of memory. A word consists of 48 binary bits. Each is capable of storing a signed 11 digit fixed point number, 8 alphabetic characters or a 10 significant digit floating point number. It is equipped with seven magnetic tape drives, paper tape reader-punch, card reader-punch and printer. Throughout the programme system advantage is taken of the magnetic tapes available to store partly processed data while printed results are examined.

4. The Efficient Assembly System (E.A.S.Y.)

EASY is a symbolic three-address assembly system of coding. It is a versatile language in the sense that every bit in each word can be manipulated by the programmer. This is an advantage in sorting procedures and as such is used to the utmost extent in collating photogrammetric points throughout the programme system.

While not a pure mathematical language it is satisfactorily adapted to it, using special subroutines available through the Honeywell library. Floating point arithmetic is generally used throughout the system. While this ensures precision in computation it has the

disadvantage in EASY of not being readily available in defloated form. Consequently many of the results required for checking purposes e. g. residual parallaxes and pass-over differences are printed directly in floating point while the more important results e. g. adjusted co-ordinates, have been defloated and printed in correct decimal point form. Close to 4,000 EASY instructions excluding subroutines and working locations have been used in the programming of the stereocomparator system.

5. Preparation before Programming the Stereocomparator

Before effective programming could be carried out an investigation into existing procedures and programme systems had to be made to allow for maximum usage and flexibility of these together with a formulation of the stereocomparator problem. This resulted in the modification of existing programmes, the adoption of a new numbering system and standard observational procedures.

Point Numbering System. This system was devised to cover all points observed in an aerial triangulation. It is a ten digit system of the form "AABBCCDEEEE" and is explained fully in the attached Appendix I. It replaces the six digit system used previously for UTECOM as explained by A. Zvirgzdins (4).

Theoretically this system allows for ten different point classifications, 1,000 unique points in a photogrammetric block, 100 strips per block and 100 models per strip. While these are the theoretical limits it was found necessary due to computer storage problems to physically limit the number of strips processed per block to 10 and the number of tie-points per join to 40. These limits have proved sufficient for production requirements thus far encountered.

A standard system such as this is mandatory for identification and programming purposes. It has proven ideal for programming and equally ideal in the automatic registration of stereocomparator and A8 (E.K.-5) data.

Modification of Existing Programmes. Well before the stereocomparator system was coded it was appreciated that the existing block adjustment programme would be required to carry out the final adjustment of triangulated areas. This at the time accepted cards as input either from

A-5 bridged strips or from cards produced by manual punching of printed results from the A-8 fixed base 3-dimensional join programme.

In an efficient computer system the logical and desirable procedure is the sequential programming of the work for the entire job with as little manual intervention and repunching as possible. For the stereocomparator this entails having the automatically punched photo point-pair data as initial input with little other input, except for parameter cards, throughout the programme system with adjusted co-ordinates as final output.

For this reason the block adjustment system was modified to accept the ten digit numbering system and a magnetic tape as input rather than data cards. The 3-dimensional join programme was modified to produce a magnetic tape output acceptable as input into the block adjustment system. It was planned, and subsequently achieved, to produce a magnetic tape output from the stereocomparator programme to also act as input into the block adjustment system. This design allows for the smooth flow of work from one system to another without repunching data cards. The block adjustment forms the core of the photogrammetric programme systems.

Sequence of Measurements. To minimize programming requirements and to ensure that the necessary points in a photo-pair are observed, the sequence of observations has been standardized. The computer is programmed to recognize the fiducials and scale transfer points by their sequence in the input deck.

Ten columns of the keyboard on the console are used for registration of the point number. An eleventh column (A) is used to indicate the end of a model, end of a strip and panel disposition of the photo-pair observed. The panel disposition needs to be known for correct application of the film shrinkage correction. The programme only accepts strips triangulated from left to right in the comparator. The observational sequence is as follows.

- (a) The four fiducial marks in order 1 to 4. The order is in reference to the panel disposition on the diapositives. For panel-down in the eleventh column A = 4 and panel-up A = 5. (Figure 4.1)

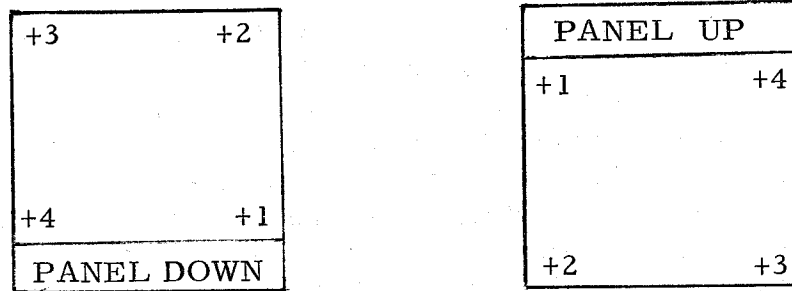

Figure 4.1. Position of data panel on diapositives

- (b) The a, b and c pass-points on the left of the photo-pair which are to be used as scale transfer points to connect models. $A = 0$ for these.
- (c) All other points (except pass-points) in arbitrary sequence in the photo-pair. $A = 0$ for these.
- (d) The a, b and c pass-points on the right of the photo-pair. $A = 0$ for a and b points. $A = 1$ for the c pass-point being the last point in the photo-pair or $A = 2$ if this is the last photo-pair in the strip.

At one stage the data cards were the only permanent records of the measurements made. Difficulties were initially encountered due to malfunctions of the automatic recording equipment. This resulted in many illegally punched data cards being produced and escaping detection before computer input. A special programme was written to detect these cards. This programme fulfills a three-fold purpose.

- (a) It detects illegally punched data cards thus allowing for their correction before entering the main sequence of processing.
- (b) It produces a permanent hard copy of the observations.
- (c) This hard copy can be visually checked to ensure that the observational sequence is correct.

6. The Stereocomparator Programme System

General Flow of Work. Due to the limitations of memory and amount of calculations involved the system is split into five separate programme segments. The first forms the uncorrected plate co-ordinates and computes and applies corrections for film shrinkage, earth curvature, refraction and lens distortion. The second is the stereogram solution. The third joins models forming strip co-ordinates. The fourth applies a linear conformal three-dimensional transformation to each strip. The fifth averages common points within strips and sorts all points in the block onto magnetic tape in a format suitable for block adjustment input. A general flow chart of the Photogrammetric programme systems is shown in Appendix II. Reference to this appendix will give a clear picture of our photogrammetric programme systems.

1. Formation of Uncorrected Plate Co-ordinates -

These are formed by the rotation and summation of the reseau and micrometer readings of a point through the recorded angle. Within a photo-pair each point may be read with different plate rotations thus allowing for any accidental or intentional rotation of the plate holders.

2. Plate Calibration -

Calibration data is available for each grid plate used on the comparator. Maximum calibrated correction is 2 microns. These corrections are not accounted for in the programme due to their small size, the probable error in point identification and the amount of additional programming necessary to allow for them.

3. Film Shrinkage -

This is achieved by the application of a perspective transformation. A unique solution for the eight co-efficients for each plate is obtained using the calibrated and observed co-ordinates of the four fiducial marks. The calibrated fiducial co-ordinates with principal point as origin are introduced into the computer using a parameter card. This is done to accommodate for the variation in calibration data with different cameras. Plate co-ordinates resulting from this transformation have the principal point as origin.

4. Earth's Curvature and Refraction -

Refraction for each point is calculated using a parameter function as described by Leyonhufvud (1). This function expresses the effect of refraction on photo images using the standard series of refraction for the I.C.A.N. atmosphere. Earth's curvature correction is combined with this to give a composite correction. Flying height and camera focal length are introduced into the computer by parameter card to allow for different flying heights and different cameras.

5. Lens Distortion -

This is based upon a third-order correction curve computed from distortion data for our camera and is a function of the radial distance from the principal point. Parameters in this equation, for our particular camera, are held in memory as constants or may be introduced into the computer using a header card if a different camera is used.

Any one or all of the corrections from 3. on may be applied or omitted at the discretion of the user.

Stereogram Solution. Relative orientation of photo-pairs is achieved using a single-centre orientation technique as described by Thompson (10), (11) and is similar to the Ordnance Survey Method. It is an iterative least squares process using coplanarity condition equations. The computer is programmed to carry out four iterations per model and to use all points observed in a photo-pair (except for the four fiducials) for orientation. Maximum number of points per model is set to 40. Print out consists of model co-ordinates, scale factors, residual parallaxes and relative orientation matrices.

Strip Formation. The stereograms are connected right to left by successive transformations using the relative base components, scale factors and matrices computed for each stereogram solution. Scale factors used are those derived for the a, b and c pass-points common to models. Print out consists of strip co-ordinates with orientation and scale based upon the first model in each strip. Pass-over differences between models are also printed out.

Three-dimensional Transformation. A conformal three-dimensional linear transformation is applied to each strip to bring co-ordinates into an approximate ground system, known scale and to account for planimetric and height errors due to the original neglect of tilt in the first model. For this the co-ordinates of three known points suitably placed in each strip are required. If values of ground control are not available then values of suitably placed points may be derived from previously processed strips. For each strip this ground system is transformed into the "Axis of Flight" system whose X axis passes through the first and last projection centres of each strip. Three input cards containing transformation point numbers and co-ordinates at a chosen scale are required per strip. Print out consists of the unadjusted strip co-ordinates in the ground and "Axis of Flight" systems and are at the same scale as the input data. After this stage of processing the co-ordinates of successive strips are in a compatible ground system and in separate "Axis of Flight" systems.

Application of this transformation has produced results in height very close to finally adjusted height values. Maximum height discrepancy to be adjusted for from strips so far processed has been 1mm. at 1:25,000. Again this transformation has so far kept the difference in tie-points along joins between successive strips well below 1.2mm. at 1:25,000.

Magnetic Tape for Internal Adjustment. Successive strips requiring block adjustment are only processed via this segment. The block adjustment requires strips to be in approximately the same co-ordinate system with the X co-ordinate axis roughly parallel to the centre line of the strips. This occurs for strips flown in an east-west direction. Strips not flown this way are said to be oblique. For these this segment linearly transforms the previously computed ground system of co-ordinates into the "axis of flight" system of the first strip thus forming a co-ordinate axis system suitable for the block adjustment programme. Further still this segment averages common points within strips, sorts out tie-points along joins and produces a magnetic tape with format suitable for block adjustment input. Print out consists of all points together with tie-points along joins.

If results after this stage of processing are found to be non-acceptable or partially acceptable then the error may be corrected in the original input deck and the previous processing stages re-run. Alternatively

new cards may be punched for the useful data and a new tape produced for the block adjustment via a special card to tape programme. Decisions here are based upon the nature of the error, the size of the job in question, urgency of results and computer time involved.

7. Block Adjustment System

The planimetric block adjustment is divided into two separate processing stages. The first takes care of the internal agreement between strips allowing for a maximum of 40 tie-points per join. The second fits the whole block to ground control based upon a maximum of 30 controls in the block. It follows the methods originally programmed for UTECOM which is adequately described by Bervoets (2), (3) Zvirgzdins (4) and Fouad Amer (9).

8. Strip Adjustment System

At the end of the strip formation or strip transformation phases of processing the tapes produced may be passed through a strip adjustment system. This is capable of carrying out any one or more of the following four strip adjustments on one pass through the computer:-

- (a) Conformal 2nd order planimetric adjustment.
- (b) Conformal 3rd order planimetric adjustment.
- (c) Near conformal 3-dimensional, 2nd order adjustment.
- (d) Non-conformal 3rd order height adjustment.

9. System Checks and Processing

Being one of the many Honeywell-400 users we have only medium access to the computer. A break down in any processing phase could delay production up to a week. For this reason and to obtain maximum results from a single pass through the computer processing is divided into the following phases:-

- (a) Print out of comparator cards.
- (b) Formation of corrected photo, model, strip and transformed strip co-ordinates.
- (c) Internal adjustment or strip adjustments.
- (d) External adjustment.

Sufficient print-outs e.g. residual parallaxes, pass-over differences etc. are produced to allow for external checks at the end of each processing stage. At present there are no internal checks or rejection of points within the computer except for the normal error routines to safeguard against physical machine errors e.g. magnetic tape read or write errors. These may be included at a later stage in the light of experience gained with the system as it now stands.

10. Proving the Programme

In programming it is always a great worry to know when one has checked the system to a sufficient degree. It is not enough to say that the results seem sensible without checking them against known results. Check data was obtained from the Tasmania Lands and Survey Department use of which is very gratefully acknowledged. This consisted of photo-pair co-ordinates with known stereogram solutions. Strip co-ordinates for these were manually computed and the programme coded to accept either stereocomparator data cards or photo co-ordinates cards directly. Again stereocomparator data for a photo-pair was obtained and the photo co-ordinates and corrections manually computed. Proving of the programme was successfully carried out on these.

11. Computer Processing Times

Typical computer times based upon a strip of 13 models with 16 points per photo-pair are tabulated below. These do not include computer set up times.

<u>Operation</u>	<u>Time</u>
Data card print-out	30 secs./strip
Formation of corrected photo-co-ords.	25 secs./photo-pair
Stereogram Solution	25 secs./model
Strip formation	60 secs./strip
Strip transformation	30 secs./strip
Averaging and sorting points	120 secs./5 strip block

A production job containing 5 of the above strips requires approximately 70 minutes computer time to process the data via these phases.

For the same job with an average of 14 pass-points per join internal and external adjustment, using 25 control points for external solution, require approximately 9 and 4 minutes computer time respectively.

12. Results

Full scale production using the stereocomparator and computer programme system began in March, 1966. Since then eight standard mapping sheets (500 mile areas, approximately 5 runs by 14 models) have been observed and processed together with a number of large scale projects jobs.

Internal and external adjustment results from these have been in sympathy with those shown by Bervoets (3) using analogue triangulation techniques. Mean square pass-over differences in x, y and z have been in the order of 6, 10 and 16 microns with maximum of 30, 67 and 92 microns at photo scale respectively. Mean square residual parallax for each job has remained relatively constant at 4 microns at photo scale with maximum residual parallax, obtained so far on any one point, of 11 microns at photo scale.

13. Conclusions

1. The accuracy of final results are in sympathy with those obtained using analogue triangulation techniques.
2. Results are obtained faster and with less manual intervention than those obtained from first-order analogue triangulation techniques.
3. More concentration can now be placed on the preparation stages prior to observations.
4. An integrated programmed system such as this which allows for the free flow of work from original comparator, model or strip co-ordinate observations to final adjusted co-ordinates is in line with modern system analysis procedures and is necessary for efficient computer usage.

5. Use of the stereocomparator has resulted in our first-order instruments being basically relegated to large scale plotting projects.
6. The stereocomparator operator should have a basic knowledge of the requirements of the computer programme system.
7. Use of the stereocomparator should allow for a build up of a reserve of plotting work.
8. Few errors have occurred in model and strip formation calling for a re-run of a production job. When these have occurred they were due to the inexperience of the observer and his lack of knowledge of the programme requirements. Now with experienced observers and again as we have only limited access to the computer there seems little need for internal checks within the main body of the programme system. If these are included at all they should be basically simple checks and placed in the first phase of processing which checks the order of observations and legality of cards.

Acknowledgment

This paper has been prepared under the direction of the Surveyor-General, Department of Lands, with the approval of the permanent head. The use made of official records is gratefully acknowledged.

References

References used in formulating the Photogrammetric Programme Systems were:-

- (1) A. Leyonhufvud. On Photogrammetric Refraction, Photogrammetria No. 3, 1952-3.
- (2) S.G. Bervoets. Block Adjustment, Cartography Vol. 2, No. 4, 1958.

- (3) S.G. Bervoets. Further Thoughts on Analytical Adjustment Including Analyses of Results, Cartography Vol. 3, No. 3, 1960.
- (4) A. Zvirgzdins. Present Techniques and Modifications for Electronic Computing, Cartography Vol. 3, No. 3, 1960.
- (5) I.A. Harley. Some notes on Stereocomparators, The Photogrammetric Record Vol. IV, No. 21, 1963.
- (6) F.E. Ackermann. The Northern Rhodesia Analytical Triangulation Test, I.T.C. Publication Series A, No. 19/20.
- (7) D.W.G. Arther. A Stereocomparator Technique for Aerial Triangulation Ordnance Survey, Professional Papers, New Series No. 20.
- (8) H.A.L. Shewell. The Use of the Cambridge Stereocomparator for Aerial Triangulation, The Photogrammetric Record Vol. 1, No. 2, September, 1953.
- (9) Fouad Amer. Digital Block Adjustment, The Photogrammetric Record Vol. IV, No. 9, April, 1962.
- (10) E.H. Thompson. A Rational Algebraic Formulation of the Problem of Relative Orientation, Photogrammetric Record Vol. 3, No. 14, 1959.
- (11) E.H. Thompson. A Method for the Construction of Orthogonal Matrices, Photogrammetric Record Vol. 3, No. 13, 1959.
- (12) F.J. Doyle. Analytical Photogrammetry, Manual of Photogrammetry Vol. 1, Third Edition. Pages 461-512.
- (13) C.H. Barrow. Very Accurate Correction of Aerial Photographs for the Effects of Atmospheric Refraction and Earths Curvature, Photogrammetric Engineering XXXI No. 5, 1960.

APPENDIX ITen Digit Point Numbering System

General form AABBCCDEEE

where

AA is the last two digits of the photo number in which point occurs.

BB is the run number in which the point is observed.

CC is the common run number - if the point is not common to another run, then the run number is repeated.

D is the classification of the point.

Classification No. (D)	Representation
∅	Tie point
1	Top pass point
2	Centre pass point
3	Bottom pass point
4	Control point (Horizontal)
5	Control point (Vertical)
6	Point from an adjacent block
7	Supplementary point (including cadastral Pt.).
8	Extra Relative orientation point
9	Fiducial point

Classifications 8 and 9 are only used in stereocomparator work. They are used by the programme for film shrinkage and relative orientation respectively and then eliminated.

EEE Point numbers chosen for classifications 0 to 7. Each number is unique in approximate series throughout the block.

e.g. Point number 9501020031 represents tie point numbered 31 observed in run 1, model 95 and is on the join between runs 1 and 2.

General Flow Chart - Photogrammetric Programme Systems.

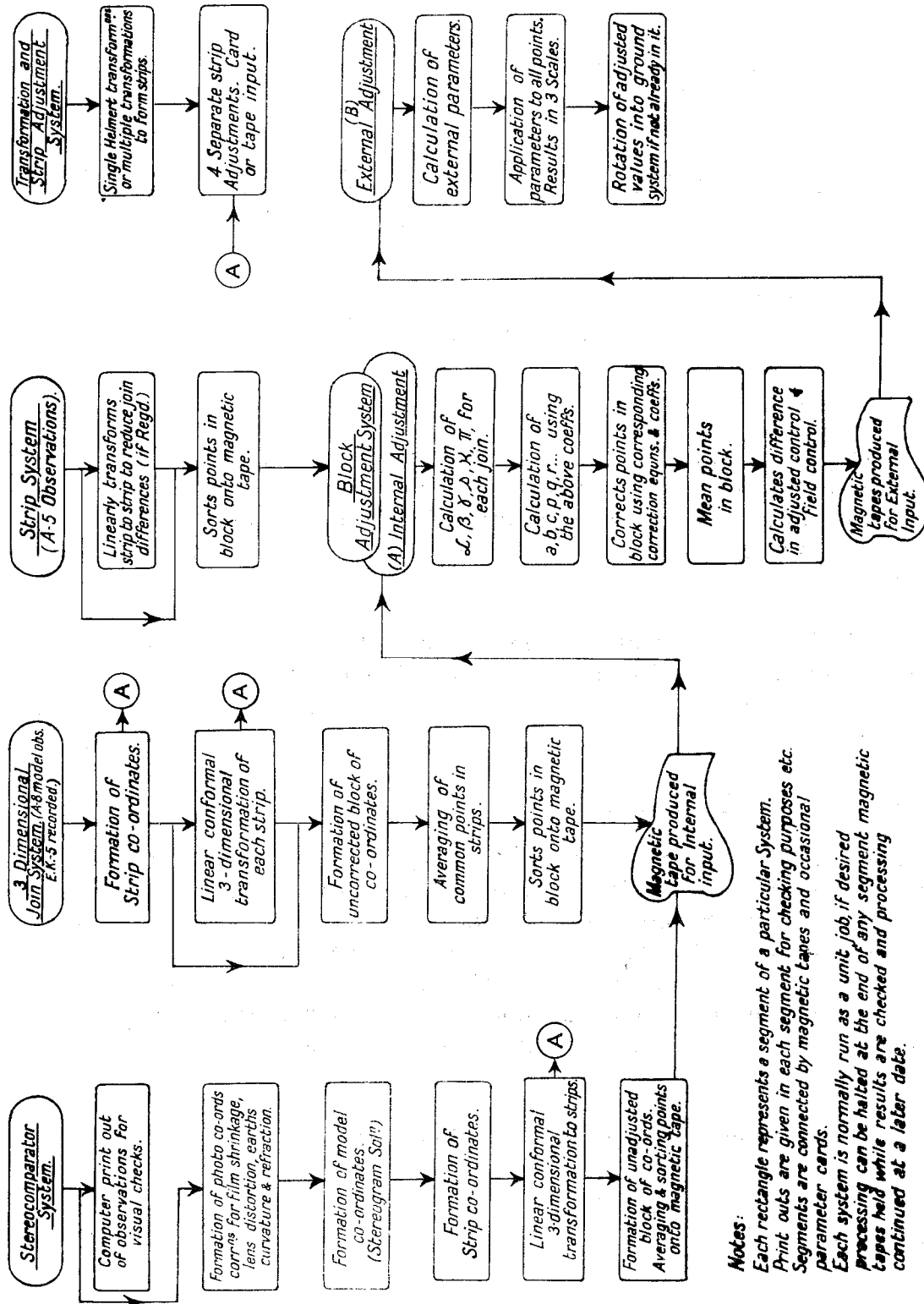

Notes:

Each rectangle represents a segment of a particular System. Print outs are given in each segment for checking purposes etc. Segments are connected by magnetic tapes and occasional parameter cards. Each system is normally run as a unit job, if desired processing can be halted at the end of any segment magnetic tapes held while results are checked and processing continued at a later date.

CONTROL FOR AND BY BLOCK ADJUSTMENT

by

F.H. Edwards

Abstract. This paper outlines what is required of control for block adjustment and of control from block adjustment. It supports the Bervoets system in a practical environment from results and experience in production. A method is described which can be used to quickly isolate control errors.

Following an analysis of the results gained from Victorian "blocks" an empirical formula is suggested which will predict the mean square error of a block.

1. Victorian Computer Programme

In 1961 the Victorian Department of Lands and Survey completed the development of an electronic computer programme for photogrammetric block adjustment. This programme, based on the principles suggested by S.G. Bervoets varied the original procedures inasmuch as the original article (1) published in 1957, was simplified to allow an easy solution by hand calculation and graphical methods. In the programme these simplified methods were replaced by more sophisticated numerical routines.

To date thirty satisfactory block adjustments have been completed under this system.

Although analytical methods are used in connection with both large and small scale mapping activities, most of the experience in Victoria has been gained with project mapping which demands a high degree of accuracy in its finished product. The production of project plans does not strictly come under the classification of "mapping", nevertheless a representation of these large scale projects is included in the analysis of this paper.

Examples and inferences are all based on the limited experience gained in Victoria with an almost static configuration of operators, cameras and instruments.

2. Ground Control

What are the features of the ground control required for a block adjustment? An aerial photograph, the unit from which a block is built, does not possess the magical property of producing results more accurate than the field survey which controls it. Most aerial surveys are completely dependent upon the ground survey done in conjunction with it. This is particularly true (errors excepted) in the case of a block. By and large photogrammetric strips and blocks are no respecter of the ground surveyor. Navigational hazards will sometimes cause a strip to deviate from its ideal position and occasionally points posing difficult field problems are required. Despite the field difficulties these points must be located accurately and every effort is made to ensure this.

Where possible the control point or its associated trig station is made to form an integral part of a closed geometric figure which can provide an independent check. Sometimes this is topographically and/or economically impossible and recourse is made to a single radiation together with an electronically measured distance. This type of point without an independent check can give much trouble. This sort of point must be determined a second time on a different day and where possible using a different RO for the geodetic angle and an eccentric for the distance measurement.

Luminous targets are preferred to opaque ones and the electronically determined course or approximate distance is tested against the vertical reciprocal angles using a standard earth radius and coefficient of terrestrial refraction.

The photogrammetrist does not question the field values he is given and regards them as error free. Obviously this is not quite true as over distances involved in 1:250,000 mapping we might expect absolute errors of ± 5 feet in the primary survey alone. In the case of 1:50,000 mapping we could expect our control to have a basic error of ± 3 feet. Finally, in the case of project mapping at 1:5,000 we would hope to achieve an accuracy of better than ± 1 foot for points located by our control survey.

The photogrammetrist requires the field values of points identified on the photograph. These points must be such that they can be observed photogrammetrically to an accuracy commensurate with that of a control point. If this is not so all the effort expended in its accurate fixation in the field is of no avail.

Where possible naturally occurring features are used as photo points. This can be difficult in heavily timbered or uniformly scrubby terrain and where impossible, clearing and pre-marking must precede the photography.

If naturally occurring points are used, these are picked in triads. This is to guard against mistakes in identification on the ground or the differences between the field and office interpretation of the centre of a particular object. When the latter error is present this is shown up during the adjustment by markedly different vector corrections to the three adjacent points; this is because adjacent "error free" points have highly correlated vector corrections: see Figure 5.4.

Large scale project mapping requires low altitude photography and where this is over a cleared and grassed gently undulating surface there is such a lack of detail that pre-targeting is necessary. The targets are made of plastic, they can be folded, carried and set out quickly and easily. They are a square of black with a square yellow centre. Squares of 2 feet or 6 feet are used, depending upon the flying height.

Reference marks are trenched and the target centered over it. On completion of the photography the targets are recovered without interfering with any uncompleted survey. These reference marks provide a useful record in the event of any further ground work.

3. Blocks and their Adjustment

Fouad Amer (2) classifies block formation into three groups:

1. Block comprised of a set of unadjusted strips.
2. Block consisting of sets of bundles of rays.
3. Block consisting of a set of independent models.

He considers that group 1 to which the Bervoets system belongs is "simply a continuation of the old way of thinking - and a rather unfortunate solution". He prefers to regard the block as a series of separated models, but admits that with standard techniques of 60°/o forward overlap and 30°/o side lap the three-dimensional linkage along the strip is stronger than the linkage down through the block. The linkage between adjacent strips is inclined to be a "hinge joint" along the common points with only planimetric strength.

There is agreement that greater strength exists along a strip and so it is desirable that the relative positions determined within a strip be deformed as little as possible.

We might now infer that the weakest link is this hinge joint and so the old approach of making adjustments on the bases of this hinge joint still merits consideration. This approach in practice has the advantage of a direct solution of a limited number of unknowns which allows segmentation and the utilisation of smaller electronic computers.

Provided torque and sag along a strip are small, we assume correlation between plan and height adjustment to be negligible, allowing simplification of individual processes by treating these two adjustments separately. Victorian experience indicates height errors and plan errors to be of a different nature and in this paper further discussion is confined to planimetric adjustment.

What does a practical mapping authority want from a block adjustment?

1. It requires that in and between the strips, the values are harmonised in such a way as to give a continuous plot from the individual models.

2. It requires that the values on which the models are set up give minimum distortion to that model.
3. It requires that the values are such that the resultant plan falls within the desired accuracy.
4. It requires that any given out values of a particular point will be sufficiently accurate to control an adjacent block.
5. It expects that the system will reduce the amount of field work in obtaining control.
6. It hopes that the system is capable of providing some form of quality control with checks at critical stages.

There is a high probability that raw observational data will contain a small percentage of errors which must be eliminated or resolved before proceeding.

Any systematic method of data smoothing must rely on some logical assumption which may or may not approximate the truth. A standard simple approach is to regard the error propagation through the strip as a constant which occurs in transferring scale from model to model, with a similar rule applying to the rotational parameter errors. Then for convenience, considering this as a continuous function instead of a step function, the "instantaneous" error factors become a linear function of x , whence strip deformation becomes a second-order function of the distance along the strip, x .

Practical results show that this is a workable assumption most of the time, but on occasions there is a third-order tendency (4). This third-order effect as often as not can be attributed to a discontinuity in the scale or azimuth factors mentioned by Amer (2). Whilst a third-order curve may satisfy the x corrections, the y corrections may still remain second-order or linear (see Figure 5.6). It is considered unwise to employ any function higher than second-order for planimetric adjustment as the higher order curves tend to absorb mistakes and result in serious departures from the truth.

The fundamental idea proposed by Bervoets (1) is that successive strips are fitted to their predecessors by using the most appropriate second-order conformal transformation. After this "internal adjustment"

the computer programme applies arbitrary correction curves second-order in both x and y to reduce the internal values to adjusted values.

For the effective development of these curves 9 symmetrically located control points are used, groups of 3 points being collinear and forming parallel lines.

When in practice conditions do not substantially deviate from the assumptions and only small residual errors are involved, any form of arbitrary smoothing curve is satisfactory. On the other hand, should there be a deviation or an error in control, these arbitrary correction curves can produce undesirable side effects.

In some blocks much time and effort is spent on isolating and eliminating errors associated with control points - the arbitrary adjustment which gives zero residuals on 9 points renders this very difficult at times. This search is made easy if extra suitably located independent control is available. In the absence of this, a means of quickly locating a defective point is most desirable.

4. Natural Block Development

If our second-order postulation is valid, we could assume that the "internally adjusted" or "naturally developed" block will retain the attributes of a second-order conformal transformation. This factor can be tested in practice.

The rigorous second-order conformal transformation formulae

$$x' = a_0 + a_1x + a_2(x^2 - y^2) - b_1y - 2b_2xy.$$

$$y' = b_0 + b_1x + b_2(x^2 - y^2) + a_1y + 2a_2xy.$$

require only three points to uniquely determine the transformation. If the mean square error given by the best fitting conformal transformation is of the same order as the expected m. s. e. of the block, we could say that our assumptions are valid and the naturally formed block is indeed conformal. A brief analysis of this is shown in Table I, which includes the m. s. e. of independent check points against the m. s. e. of the 9 standard

control points under different conditions of conformal and arbitrary adjustment. As the arbitrary curves give zero residuals at the 9 points the only valid assessment of the m. s. e. here is on the check points not used in the adjustment. Orbost is included as a bad example and will receive separate attention. Apart from Orbost the figures that have been obtained encourage the investigation of the above idea.

TABLE I

COMPARISONS OF MSE'S: CONTROL AND ADJUSTMENT

Name of Block	Number of Check Points	Vector M.S.E. - Feet				
		(1)	(2)	(3)	(4)	(5)
Orbost	7	22.5	27.2	23.0	-	32.3
Scoresby	32	2.9	-	2.0	2.2	2.1
Echuca	19	0.9	-	1.5	-	-

<ol style="list-style-type: none"> 1. M.S.E. of check points, when control is at 9 standard points, using arbitrary adjustment. 2. M.S.E. of check points, control at 9 standard points, using the conformal transformation. 3. M.S.E. of the 9 standard control points, using these same points for control and adjusting by conformal transformation. 4. M.S.E. of the 9 standard control points, using only 5 as control, adjusting by conformal transformation. 5. M.S.E. of the 9 standard control points using only controls at the four corners, adjusting by the conformal transformation.

Figures 5.1 and 5.2 show diagrammatically the naturally developed blocks of "Scoresby" and "Orbost".

EXAMPLES OF NATURAL BLOCK DEVELOPMENT

CONTROL POINTS
○ Standard ○ Check ⊗ Error

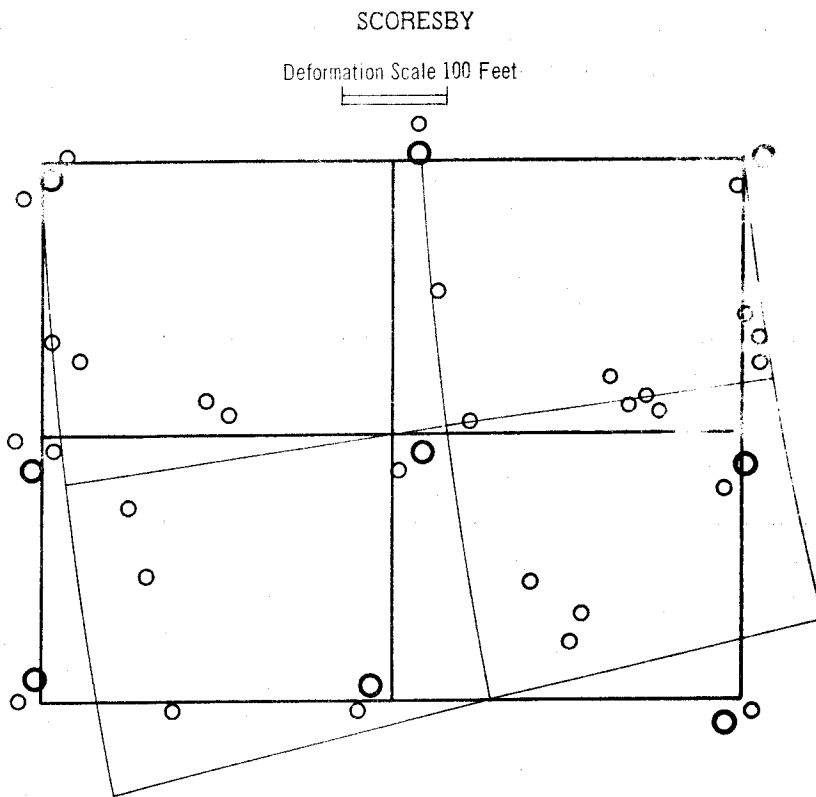

FIGURE 5.1

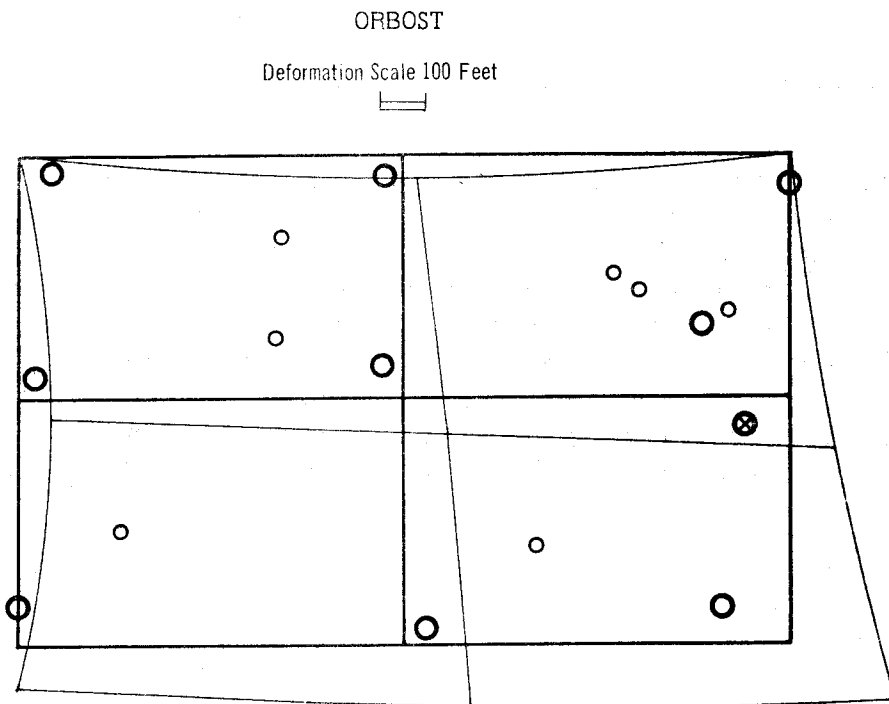

FIGURE 5.2

Therefore, if we want to locate a defective member in one of our nine points and as we require only three points to transform an entire block, the simultaneous use of the 9 points with a least squares solution is the answer. The offending point is distinctly indicated by its residuals: see Table II.

TABLE IIORBOST

Conformal transformation with control at 9 points
* Point 6 in error

Residuals in feet

Point	Diff E	Diff N
1	4.9	- 9.8
2	- 9.0	-16.4
3	31.9	- 9.0
4	-37.7	- 7.4
5	-20.5	1.6
*6	31.2	50.8
7	27.1	8.2
8	32.8	- 1.6
9	- 0.8	25.4

At this stage it is profitable to investigate the effect of an error on a second-order conformal transformation. Figure 5.3 deals with an error occurring at one point where only three control points exist. This error in all cases is in x and is of the same magnitude. Error curves corresponding to various combinations and locations of faulty control are shown. These have been obtained by considering a square block to be transformed into itself. Instead, an error has caused a difference in transformation indicating the propagation of error through the system. Note that in places the vectorial magnitude can be larger than the initial error.

CONFORMAL DISTORTION PATTERNS
FOR PARTICULAR COMBINATIONS
OF CONTROL AND ERROR LOCATION

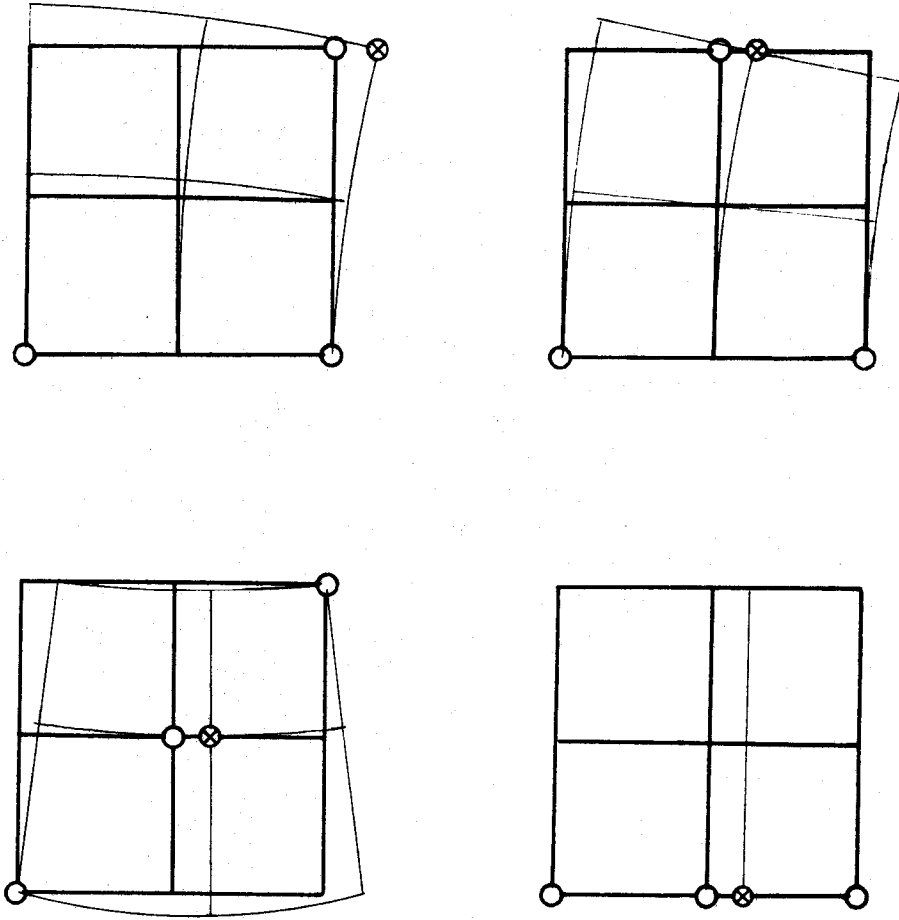

FIGURE 5.3

ADJUSTMENT CORRELATION IN A LOCALITY

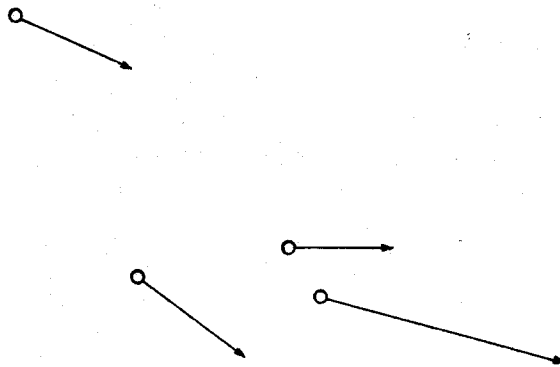

FIGURE 5.4

5. Reduction of Field Control

Field Control has been substantially reduced by existing block methods and it is tempting to ask is it possible to make a further reduction in the existing 9 points.

In most cases where the naturally formed block has been substantially conformal, a second-order conformal transformation to ground control has not significantly increased the vector m. s. e. of the residuals and the 9 points could be reduced to 5 or 4 with one at each corner without a substantial loss of accuracy; see Table I.

Experiments in the Victoria Lands Department of a purely mathematical nature with conditioned quantities have shown that control around the edges and at the four corners of a region is far more significant than in the middle where internal conditions govern the strength. Amer has come to the same conclusion (2). Provided that the internal agreement between strips has given no cause to suspect a natural second-order development of the block, a conformal transformation on a reduced number of points should not result in a marked loss of accuracy. This does not advocate the reduction of control but rather a method to be used with discretion when it is not feasible to obtain the full set of control points.

6. Block Accuracy

Does a criterion exist in this particular system whereby we are able to assess or judge the accuracy of a particular block?

From previous analysis (3) a block m. s. e. has been given as 0.06mm. at picture scale.

But to investigate this question, consideration must first be given to the factors which govern the accuracy of the block.

1. the validity of the assumptions used to form the block
2. the observing capabilities of the photogrammetrist
3. the precision of the photogrammetric instrument
4. the method used for aero-triangulation
5. the film and lens reliability
6. the camera focal length
7. the altitude of the photography

BLOCK ACCURACY FACTOR

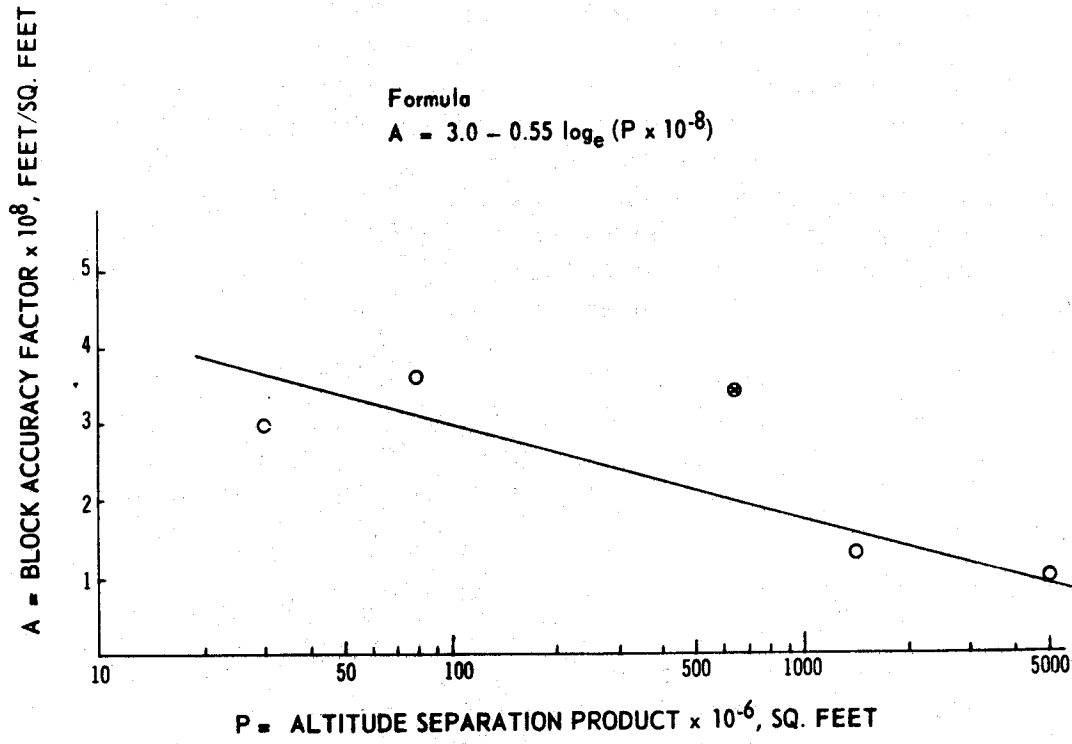

FIGURE 5.5

COMMON POINT DIFFERENCES BETWEEN STRIPS

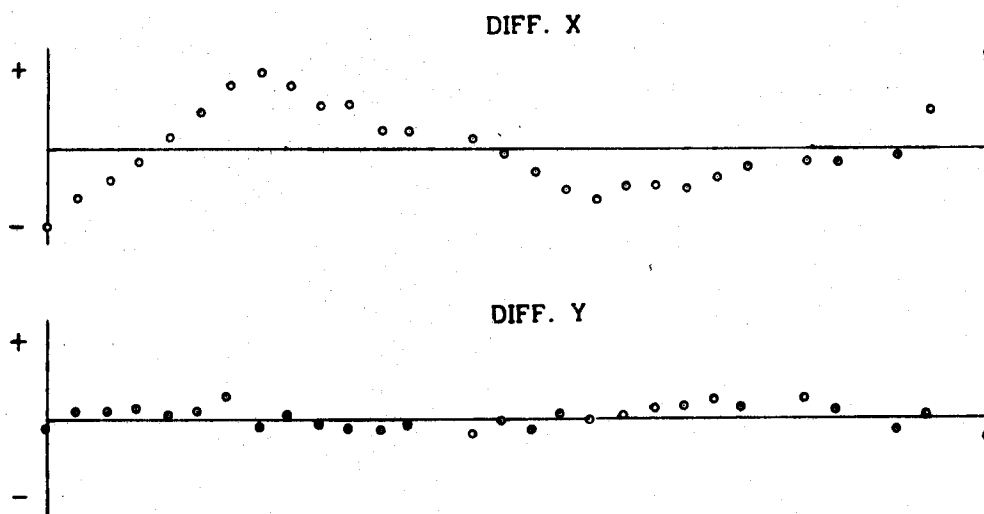

FIGURE 5.6

8. the number of models in a block
9. the density of control and size of block
10. the basic accuracy of the ground survey.

It is presumed that aero-triangulation will be performed by the best observers with the best instruments available to the organisation. Aero-triangulation has been done in the Victorian Lands Department using Wild A7 instruments by employing conventional base in - base out methods on independent models. The blocks analysed so far do not include one observed on the stereocomparator. For a given establishment we might regard factors 2. to 4. as being fairly constant.

Some of the factors, such as 6. to 9. and even 10., cannot be regarded as completely independent. In an attempt to formulate a simple rule it was thought that the m. s. e. of a block might be considered as a function of two major variables; the flying height and the separation of the ground control.

As mentioned any m. s. e. 's calculated are based on independent check points, as the residuals are zero on the 9 control points. After this adjustment, the second-order arbitrary curves will leave a presumably second-order pattern of residuals, whose variance can be shown to be proportional to the square of the distance between the zero residual points and whose m. s. e. is therefore proportional to the distance.

All observed values, whether control points or not will have an observational m. s. e. dependent upon such factors as operator, instrument, camera flying height etc. We will allow all of these to be represented by the flying height.

Because the total m. s. e. will be inversely proportional to some function of both these factors, the altitude separation product P, will be defined:

$$P = H \times S$$

where H = flying height

S = separation of control.

Now consider an empirical Block Accuracy Factor "A" defined by

$$A = \frac{\sigma}{P}$$

where σ is the m. s. e. of the block. Evaluating A from the results of different size blocks it was found that this was not a constant but decreased with an increase in P, i. e. it was still some function of P: see Table III.

The fundamental error will be a function of the field survey which on small blocks flown at low altitudes could be of the same magnitude as the photogrammetric error and it would thus be impossible to discriminate between them. Although the field error increases along with S it is obvious that its proportionate effect on A progressively decreases as P increases.

If A could be predicted in terms of P we would have our criterion.

$$A = \frac{\sigma}{P} \quad \text{for any given block}$$

$$\therefore \Delta A = \frac{1}{P} \cdot \Delta \sigma - \frac{\sigma}{P^2} \cdot \Delta P$$

$$\frac{\Delta A}{\Delta P} = \frac{1}{P} \left(\frac{\Delta \sigma}{\Delta P} - \frac{\sigma}{P} \right)$$

As A is not constant the term in brackets is not zero but will be small and will not vary as rapidly as P, so regarding this as a constant = -m.

$$\frac{dA}{dP} = - \frac{m}{P}$$

$$\therefore A = c - m \log_e P$$

and from practical figures: see Figure 5.5

$$A \times 10^{+8} = 3.0 - 0.55 \log_e (P \times 10^{-8})$$

TABLE III
 DETAILS OF BLOCKS AND "A" FACTORS

Units Feet

Name of Block	Camera	Flying Height	Block Size	No. of Runs	Mods per Run	Mean Control Separation	0.06mm at Ph. Scl.	Obsv MSE	Factor A
Echuca	RC7	3000	25000 x 15000	7	18	10000	1.7	0.9	3×10^{-8}
Scoresby	RC7	4000	48000 x 35000	10	23	21000	2.4	2.9	3.5×10^{-8}
Orbost	RC5	12000	150000 x 90000	7	21	60000	6.3	22.5	3.2×10^{-8}
Eildon	RC5	15000	300000 x 180000	11	40	120000	7.8	19.7	1.1×10^{-8}
Wangaratta	RC9	(25000)	450000 x 360000	9	20	200000	17	(50)	1.0×10^{-8}

$$\text{so } \sigma = P \times 10^{-8} (3.0 - 0.55 \log_e (P \times 10^{-8}))$$

where σ is the vector m. s. e. in feet.

$$P = S \times H$$

where H = altitude in feet

S = mean separation of control in feet.

Wangaratta. To complete the series in Table III the Wangaratta block is included. The purpose of this block was to produce a 1:250,000 map. Wangaratta is an example of a co-operative effort between the Royal Australian Survey Corps and the Victorian Lands Department. The Department supplied the field control and the Army performed the aero-triangulation on their Wild A9 instruments. The adjustment was done using the Department's programme. Figures quoted in brackets are approximate.

Orbost. In practice the jobs that receive the most analysis are the ones which give the most trouble and being in this category the data was available for inclusion in this investigation.

This block is an example of a block not sufficiently bad to be completely rejected. The m. s. e. is seen to be ± 22.5 whereas the expectation value is ± 15 feet, see Figure 5.5.

Defects in this block:

1. Between two of the runs a pattern of residuals appeared which may have been resolved better by a third-order function.
2. A major fault was located in one of the standard control points.
3. Three of the control points were obtained from an old tie run which had been proved faulty.
4. The old tie run was based on values obtained by old triangulation methods.
5. New control was based on first and second-order triangulation strengthened by distance measurements.

The deformation pattern (Figure 5.1) might not illustrate poor block development as much as it illustrates faulty control.

TABLE IV

ORBOST

RESIDUALS IN FEET ON CHECK POINTS

POINT	ARBITRARY AT 9 POINTS		CONFORMAL AT 9 POINTS		CONFORMAL AT 4 CORNERS	
	DIFF E	DIFF N	DIFF E	DIFF N	DIFF E	DIFF N
A	28.7	13.1	17.2	23.8	-39.4	12.3
B	19.7	- 9.0	6.9	- 9.8	- 4.9	-22.1
C	13.1	9.0	0.0	- 0.8	-10.7	- 5.7
D	- 3.3	-11.5	-26.2	-32.8	-41.0	-39.4
E	18.0	10.7	8.2	11.5	- 8.2	1.6
F	17.2	-13.1	- 4.9	-34.4	-18.9	-41.0
G	-13.1	- 9.0	-13.1	-10.7	-24.6	-15.6
MSE	22.5		27.2		37.7	

With 4 doubtful points out of 9 the residuals of the conformal analysis (Table IV) still locates the defective point but not as markedly as it does with only one point in error.

7. Summary

The photogrammetric requirements of the Victorian Lands Department have been satisfied with the results given by the present system.

The introduction of the method of independent pairs showed an improvement in block results and it is hoped that blocks observed on a recently purchased stereocomparator might improve results further.

The system provides a measure of quality control which is felt may be lacking in other methods.

References

- (1) S.G. Bervoets. Block Adjustment. Cartography, Vol. 2, 1957-8.
- (2) Fouad Amer. Digital Block Adjustment. Photogrammetric Record, Vol. 2, No. 4.
- (3) S.G. Bervoets. Further thoughts on analytical adjustment. Cartography, Vol. 3, No. 3.
- (4) A. Zvirgzdins. Present Techniques and modifications for electronic computing. Cartography, Vol. 3, No. 3.

DISCUSSION ON PAPERS: No. 2, 3, 4 and 5 .

Chairman: Mr. H.S. Rassaby, Assistant Director of Mapping, N.S.W.

A. SPWERS: It would appear that the three main users of Stereo-comparators employ different equations to correct both for film distortion and lens distortion.

- (1) Are these equations justified?
- (2) On what basis were they derived?
- (3) Is it not dangerous to use equations which leave no residuals? e.g. for the correction for film distortion from four fiducial readings.
- (4) Do the lens distortion equations used satisfactorily correct for RC9 lenses?

M.T. NOONAN: For correction of lens distortions a third order

polynomial in r^2 was used: i.e. $f(r) = a(r^2)^3 + b(r^2)^2 + c(r^2) + d$. It was appropriate firstly because it simplified the programming and secondly because it fitted the plotted curve better than the more usual third order polynomial in r .

The equations used to correct for film distortion as shown by the measurements on the 4 fiducial marks involve eight unknowns and thus give an exact fit. However, the residual film distortion at the 4 marks, after a linear transformation to the calibrated positions, is also derived so as to give a measure of the regularity of the distortion. The method of deriving the equations is given in (3).

A. ZVIRGZDINS: For the correction of the lens distortion a third order polynomial is used.

For the correction of the film distortion a collinear transformation is used to make the observed co-ordinates of the fiducial marks agree with the corresponding calibrated values.

G. KONECNY: What is the cost of computer time involved in aerial triangulation?

NOONAN: An example of computer costs for triangulation:

Strip of 25 overlaps.

Stereogram Solution	\$14.00
Strip Formation	10.00
Strip Adjustment	<u>8.00</u>
	<u>\$32.00</u>

The cost works out at approximately \$1.30 per overlap.

J. OVINGTON: Mr. Noonan mentioned a rate of observation on the Stereocomparator of 7 models per day. I have seen estimates of a higher rate of production but taking this figure, I make this to represent 1820 models per year, if we assume full use of the instrument. (52 weeks each of five eight-hour days)

If the instrument is fully used, how does Mr. Noonan's Department manage to supply the field control for the triangulation of so many models?

The amount of plotting of medium scale mapping represented by this quantity of models would occupy the full-time employment of about 20 stereo-plotting instruments. Is such a quantity of instruments available to Mr. Noonan's Department?

While not decrying the use of the Stereocomparator in mapping, this can only be justified by full-time employment of the instrument (since it is useless when not employed in aerial triangulation). It seems evident that there are too many Stereocomparators in Australia for the amount of triangulation carried out.

NOONAN: Rate of observation of stereo-models is 7.5 overlaps/day with an average of 12 points (excluding fiducial marks) per overlap. We have sufficient field control at present. However if in the future we are waiting on control, the cross runs can be observed without field control.

There are not sufficient plotting machines. However we are investigating the possibility of co-ordinating cadastral survey by analytical photogrammetry. Also we have recently bridged two strips for the Department of the Interior. If the comparator runs out of work this type of work could possibly fill the gap.

F.H. EDWARDS: Eighteen to twenty models per day can be observed in the stereocomparator.

OVINGTON: In analogue aerial triangulation it is possible to detect blunders in field control at an early stage, sometimes in the course of the triangulation procedure. With the Stereocomparator, this is not possible until considerable expensive electronic computations have been carried out to form the models and then the strip. How much of this time (and money) is expended before blunders in ground control are detected, (including the re-observation of the affected models, together with the repetition of the electronic computations)?

ZVIRGZDINS: It is not possible to detect bad control until the strip has been formed, scaled and transformed.

KONECNY: The analytical method of executing photogrammetry normally provides a substantial number of redundancies which can be used in the detection of blunders and incorrect field control.

W.A.G. MUELLER: On the Snowy Mountains Scheme only analogue methods have been used. With these it is relatively simple to detect errors.

S.G. BERVOETS: What standards are applied in assessing the accuracy of block adjustment?

EDWARDS: Different authorities have different criteria (dependent upon their functions) for the requirements of block accuracy.

An indication of block accuracy could be given by the vector M.S.E. of independent check points not used in the adjustment. Engineering projects dictate their own accuracies so flying heights, selection of camera and methods are designed so as to achieve this accuracy.

No rule for the magnitude of the error exists, in my belief, and the proposed formula in my paper was a reversal process whereby observed block mse's were analysed under varying conditions.

CHAIRMAN: Surely the criteria which should apply are those which satisfy the requirements for producing a map of the desired accuracy ?

J.G. FREISLICH: What is the relationship between final accuracy and the accuracy of the block?

EDWARDS: This would need a lot of intensive ground checks after the map had been drawn. It would be difficult as I consider the determination or assessment of final "map accuracy" in the field a rather vague problem. No attempt by the Victorian Lands Department has been made in this direction.

A. APSENIIEKS: In the Hydro-Electric Commission, the question of accuracy requirements for photogrammetric control points to control a stereo model and ensure that the map produced will meet normal mapping specifications, is dealt with by adhering to the following criteria:

All well defined control points must be accurate to within 0.2mm. at the respective map scale. Normally, all details plotted, should be then within 0.4mm. at that map scale.

L. EEKHOUT: ZVIRGZDINS raised the question of aerial triangulation with 60% side-lap. A thesis on the triangulation of sub-blocks of photography with 60% overlap was completed by J. M. Anderson at Cornell University, N.Y. Technical reports on the subject have been published by that University.

EDWARDS has referred to the use as control points of points derived from aerial triangulation in adjacent blocks. I should like to know what provision has been made for weighting in this case.

EDWARDS: No allowance for weighting has been made in the Victorian Computer programme. Before any "passed out" control from other blocks is used it is generally checked independently in a separate strip adjustment.

The adjustment of "individual square sections" will still leave discontinuities at their mutual edges. Such an approach might be difficult for authorities who have only a small computer at their disposal.

The existing process of forming "strips" which are used in the adjustment gives a quality control, and does not require an iterative solution.

BERVOETS: So far I personally have only joined individual models into a single strip and not yet into a block. Any adjustment in the true sense of the word takes place when the stereograms are formed by relative orientation using parameters bz , ω , ϕ and χ of dependent pairs.

A matrix of variance and co-variances, or rather a matrix of weight coefficients, is set up for the purpose of adjusting the originally measured picture co-ordinates. These picture co-ordinates are in fact adjusted so that true intersections are obtained between corresponding rays. I believe the greater part of error development can be controlled by using the appropriate matrix. A comparison of results obtained with a simplified matrix and those obtained with the rigorous matrix showed that the development of warp (ω -error) almost disappeared. There is however no appreciable effect on or reduction of the longitudinal error. This question needs further investigation.

ZVIRGZDINS: In the N. S. W. Lands Department procedures no weighting of control is used. Usually points derived from adjacent blocks are used only for checking purposes. If it becomes necessary to use a derived point for adjustment, it is used with the same weight as a control point fixed by field survey.

KONECNY: I would like to take EEKHOUT's question a step further, and suggest that with the advantages offered by modern computers a full adjustment may be made taking into account all redundancies and adjusting these according to rigorous least squares.

The various steps: model formation, fitting model to model along a strip, fitting then adjusting to control and adjustment strip to strip, followed by a similar procedure for height control, is replaced by a single rigorous operation based for example on the collinearity principle: ground point, photo image point and camera nodal point must all lie in a straight line.

I. HARLEY: What is the economy of block adjustment relative to other methods of providing control?

EDWARDS: No figures (especially in dollars) are available from the Victorian Department of Lands of the economies of block adjustment. This would have required doing a job twice. I feel that about a 50% saving is achieved in field survey. This released the field staff for control of individual models so that, both systems, block adjustments and individual control can proceed simultaneously.

Block adjustment does not give something for nothing: it does increase office work as well as decreasing field work.

CHAIRMAN: My experience has been that there is a significant saving in cost. Where the use of a block adjustment has resulted in the number of control points being reduced from 35 to 9, there has been a proportionate saving in field expenses.

J. TRINDER: J. Ovington has deduced that the use of stereocomparators in Australia is unjustified from the point of view of the proportion of the time which they are used. Users have admitted that their instruments are not in constant use. Also from the point of view of the accuracy which they achieve, stereocomparators are not justified.

Stereocomparators give measuring accuracies of 3-4 microns if, as in some work in Australia, a plate camera is used. The accuracies resulting from block adjustments are quite inconsistent with a stereocomparator accuracy of 4 microns.

Should there not be a new approach towards block adjustment, and the introduction of a better, more sophisticated method of aerial triangulation, in order to use the accuracy of the comparator?

EDWARDS: A new approach to block adjustment is worth consideration. However a practical mapping authority with a given system will probably stick to the devil it knows rather than launch off into the unknown. A radical change in systems can only be justified by a significant improvement in results, when the present system is proven adequate in practice.

The Victorian Department of Lands has only recently gone into Stereocomparator work and no blocks from this have been calculated.

Any system would still require to be able to take information from existing analogue techniques.

KONECNY: We should look at the question of adjustment of strips and blocks from another point of view. In my opinion there is only one correct approach to adjustment. This takes into account all existing conditions between the original measurements in the photographs. All other adjustment procedures are approximations, which can only be justified by economics.

BERVOETS: I heartily agree with KONECNY. However rigorous methods are not necessarily justified, unless an improvement results from their adoption.

CHAIRMAN: Is not the medium of photography the limiting factor as far as accuracy is concerned?

KONECNY: In case of analytical procedures we are able to make use of redundant observations to a much greater extent. These redundancies (for example 15 orientation points instead of 5 or 6, 9 transfer points instead of 1 to 3, 90% overlap instead of 60%) will be able to reduce systematically acting errors of the photographic medium. An example of this was given for the reduction of Lunar Orbiter photography, where the use of 87% overlapping photos reduced the RMS error of the mean for the position of a point from $\pm 100\mu$ for 60% overlap to about $\pm 40\mu$ for 87% overlap.

I. J. DOWMAN: I would like to mention the fact that in all the discussions nobody has considered the small operator. In this regard there appears to be a very good case for the use of analogue block adjustment.

BERVOETS: I would like to enquire of Mr. Chambers as to the meaning of a 4K memory.

E. CHAMBERS: This refers to a computer with a memory of 4000 words, each word consisting of 48 binary bits.

P. B. JONES: I would like to ask Professor Konecny how many simultaneous equations were involved in the adjustment of the lunar photogrammetric triangulation.

G. KONECNY: About 800.

ZVIRGZDINS: It is worthwhile mentioning that in the solution of these large systems of normal equations, generally about 95% of the terms involved in the relevant matrices are zero. It is often possible to break down the solution since only the terms along the main diagonals of the matrices are of significance.

PAPER NO. 6

AUTOMATION IN PHOTOGRAMMETRY

by

G. Konecny

1. Introduction

In automation human functions are being replaced by the action of devices. The impetus to automation comes from the fact that certain devices are able to perform human tasks either much faster, more conveniently or more economically. To automate the human functions of sensing, manipulation and judgment human reactions must be copied by these devices operating according to various laws of physics. The last century commences with the development of mechanical machinery to replace a number of human manipulations. The human functions of sensing and judgment operate on electronic principles and this is why a more complete automation of processes could not begin until a revolutionary development in electronics had taken place during the last two decades.

Automation can therefore be carried to various stages. In the elementary stage one human process is simply replaced by another which is faster, more accurate, more convenient or more economical. Photogrammetry is a first stage automation of the surveying or mapping process.

2. Automation of the different phases of photogrammetric plotting

A more advanced stage of automation is entered when the different phases of the photogrammetric plotting process become automated.

The various phases of photogrammetric plotting can be classified as: data input, orientation, restitution and data output. Data input entails the collection of input material such as analog information in form of photographs, and control point identification images, and of digital information, such as the co-ordinates of control points, auxiliary data about camera positions and camera attitudes, camera calibration data about interior orientation and lens distortion, and of administrative decisions, such as plotting scale, plotting limits and alternative directions for procedures of orientation and output. Orientation is classically divided into interior, relative and absolute orientation. Restitution involves the process of converting image co-ordinates of a point into model, ground, or map co-ordinates. The data output concerns the form in which the result of the photogrammetric process is to appear: digital, in the form of numerical data, or analog in form of graphical plots of contour maps, or profiles, or of photographic reproductions, such as orthophotographs and drop-line outputs.

The phases of photogrammetric plotting involve various functions, which must be performed by man or machine: selection, correlation, mensuration, calculation, recording, plotting, interpretation and translation.

Selection is required in the phases of relative and absolute orientation, and when selected point objects are to be restituted, such as boundary points in plotting or transfer points in aerial triangulation. It is very difficult to automate this function, and the progress made so far has been in the experimental stages.

The Bendix Corporation has developed a system in which transfer points are automatically selected (1). Two stereo images are scanned by two cathode ray tubes. The cross-correlation function resulting out of the intensity modulated CRT voltages is used to test for optimum point location by the following criteria:

1. Best geometrical location.
2. Best image correlation.
3. Least slope.
4. Least surface roughness.

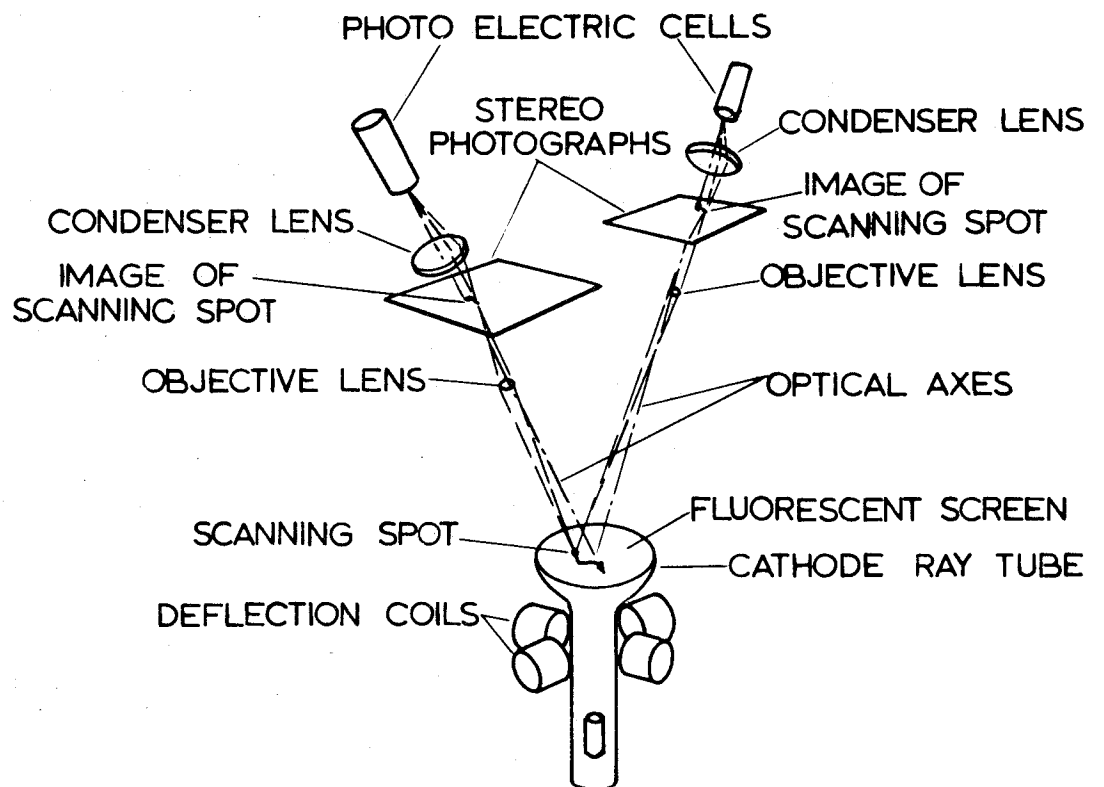

FIG. 6.1 OPTICAL SYSTEM OF STEREO MAT
I AND II

The Link Division of General Precision developed an automatic point identification, marking and measuring instrument (2). A reference photo and approximate image co-ordinates are used to select and to measure images on a photographic plate. The instrument also operates on the principles of image correlation.

Star images have been selected on the basis of precalculated approximate positions by computer; their automatic centring and measurement can also be accomplished by electronic means (3).

A practical instrument for automatic point selection does not yet exist, however. The organizational activity of collecting ground co-ordinates of points will always require human selection.

Correlation is a technique to relate corresponding images. The human counterpart is stereo-perception. Automats perform the correlating function in the following way: (Figure 6.1) One or two cathode ray tubes are subjected to a regular scan pattern. The light emitted on the face of the tube is intensity modulated when passing through different parts of the two photographic images during the scan. Two photomultipliers pick up the intensity modulated light variations and transform them into time varying voltages. These voltages are fed into an electrical analog computer, the so-called correlator. The signals are filtered, differentiated, delayed and smoothed. If corresponding images are viewed the correlator output is zero. For a time lag of one of the images, as is the case for an X parallax, the correlator produces an error voltage, which can be used to control a servo-mechanism to remove the source of the discrepancy, such as the height in a stereo-plotter or a parallax in a comparator.

Automatic image correlation is faster than human correlation, but expensive circuitry or the use of an on-line real-time digital computer is necessary to scan in such a manner that correlation will not get lost. In that case the human vision, within its limitations, can act faster.

Correlation is required for the transfer of points as well as for the stereoscopic measuring and plotting process.

Mensuration involves the determination of image or model co-ordinates. Various types of analog-to-digital converters exist to obtain an automatic digital record for the co-ordinates of all selected

points. Most systems in comparators and plotters operate on a lead screw principle, and rotational encoders translate rotations into digital counts. Faster devices, such as the Ferranti-Moire fringe counter, the laser-interferometer or the Bausch and Lomb DIG have not yet found use in photogrammetric instruments. It is in this area where speed and accuracy of automation can still considerably be improved.

The calculation function has traditionally been the one which was automated first. Von Gruber defined photogrammetry "as an art to avoid computations". The development of all analog stereoplotters, optical or mechanical, falls into this category. The advantage of all optical, mechanical or electrical analog computers is the immediate availability of the result. On the other hand all analogs are limited in accuracy and in the speed of moving from one calculation condition to another. Digital calculations, on the other hand, can be performed with unlimited accuracy; the development of digital computers has been so fast, that even complicated mathematical relations, such as the transformation from image to model-co-ordinates can be performed in real time, with all desired corrections for lens distortions, refraction, and the co-ordinate system in use. For point images this calculation is usually performed off-line, as in the case of analytical aerial triangulation. Analytical stereoplotters, which possess a digital computer as an integral part of the system perform the computations on-line in real-time. They offer the advantage of extreme flexibility. They have almost no limitations as far as type and conditions of photography are concerned; they even permit evaluations of aerial imagery systems such as strip or scan imagery over the range of the electromagnetic spectrum, which follow geometric laws other than those of the perspective. (Figure 6.2)

The recording function concerns the listing of image, model, or ground-co-ordinates, after these have been measured or calculated. Today all major photogrammetric instruments of the plotter - or the comparator - type can be equipped with readout devices such as a typewriter, a card punch, a tape punch, or a magnetic tape unit.

The plotting function requires plotting of points and lines. This can easily be accomplished by on-line co-ordinatographs. Automatic on-line plotting, however, has the inherent difficulty, that elevation information referring to contour identification or the altitude of a point cannot be recorded. Automatic co-ordinatographs, operating off line,



FIGURE 6.2 OMI-Bendix Analytical Plotter AP/C.

controlled by digital data on tape or cards, have the advantage of being able to mark points with certain symbols and to add alphanumeric information to the plot.

Most difficult to automate is the function of interpretation. In the process of plotting only a small part of the information contained in the photographs is abstracted and represented in form of a map. This abstraction involves the recognition of specific objects under varying conditions of contrast, illumination, viewing angle and scale.

A considerable effort is being put into automatic terrain type discrimination (4), (5), and into the automatic detection of objects (6), mostly for military purposes. But only elementary success has so far been achieved.

The translation function deals with the symbolization of interpreted features into the map. This problem is closely tied with the problem of identification, and no workable automatic solution exists so far.

In order to avoid the most serious difficulties connected with the automation of all phases of photogrammetric plotting, it is merely necessary to find alternate solutions for the functions of interpretation and translation. It is for this very reason, that other outputs have been sought, which permit the interpretive function to be carried out afterwards. All current automatic stereomapping systems possess an orthophoto-output, and most also produce a drop-line chart. (Figure 6.6)

For the orthophoto an overlay with all pertinent additional information and symbolic abstraction may be made on the basis of a correct geometry. To extract contours and to add elevation symbols to a drop-line chart overlay is also a simple matter. The drop-line chart must nevertheless be considered as an alternative to a contour-plan, which developed out of the difficulty to trace contours automatically; enclosed contours would repeat the contouring procedure over and over, and contouring was impossible simultaneously with the orthophoto-production.

Orthophotos have in the meantime gained widespread popularity not only as an output for the derivation of maps by cartographic techniques, but also as a substitute for planimetric maps.

A large variety of orthoprinters has been developed. These have mechanized the plotter motions and have automated the output, but they still require the correlating function of the human operator. Such systems have the advantage of a low cost and high resolution, but they are only partial solutions in the sense of automation.

Whenever it becomes possible to separate the individual functions of photogrammetric processing into separate operations a relatively simple automatic approach will be possible. This is the case for aerial triangulation: While no suitable point selection device is available to photogrammetric practice, and while automatic image correlation would be unreasonably expensive for this purpose alone, these operations can be substituted by manual selection (pricking) and transfer of points under the stereoscope or in a transfer device. The subsequent operation of mensuration and recording can be carried out in a mono- or a stereo-comparator. While the identification and selection of points is done by the operator the recording is automatically made on punch cards or punched tape. The processes of calculation and output by an on- or off-line printer, and if need be a graphical representation of the points are carried out automatically off-line and in sequence.

There is considerably room for the improvement of the automatic phase. Most formulations for analytical aerial triangulation follow the analog-instrument approach, in which model after model is formed and joined together. The strip and the block is adjusted by more or less arbitrary practical procedures, with intermediate outputs on cards used as inputs for the refining adjustments. In some cases the orientation and computation phase is still partly or completely carried out in analog instruments. This is justified, if a number of analog plotters are already available, and if they are also used for plotting purposes; but after it has been established that analytical procedures are more accurate and less costly, there is certainly no reason why first or secondary order plotters should be purchased for the main purpose of triangulation. A further improvement in accuracy and an overall saving is to be encountered by the revision of present analytical procedures. It is an established fact that computation costs per output decrease when the size of the computer increases. Most analytical programmes have been written for small computers. The logic and the data-manipulation in such programmes is wasteful in the long run. Programmes which are able to incorporate all conditions existing in a block permit a more proper treatment according to probabilistic theory; they are technically feasible in even medium sized computers of the size of the IBM 7094

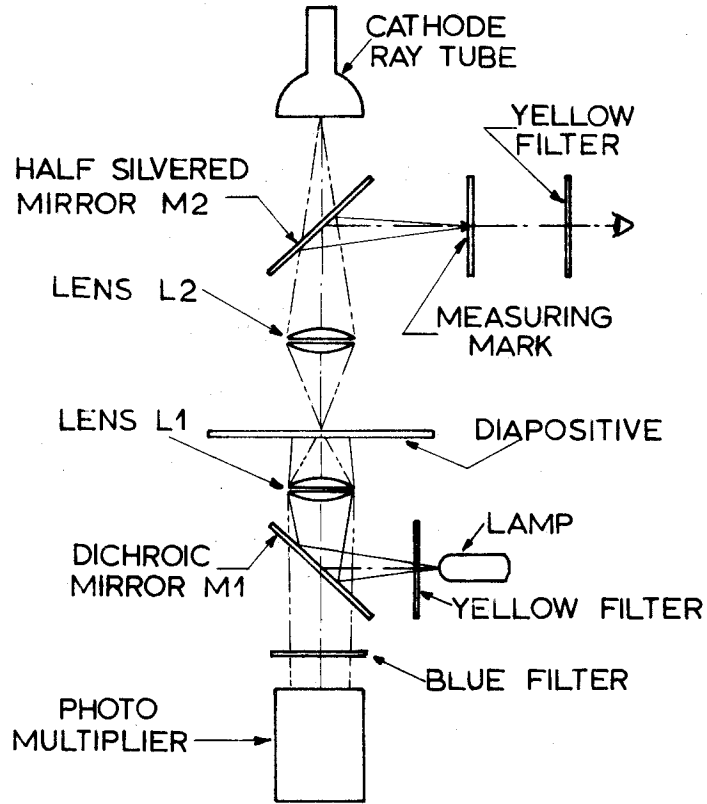

FIG. 6.3 OPTICAL SCHEME OF B-8 STEREOMAT.

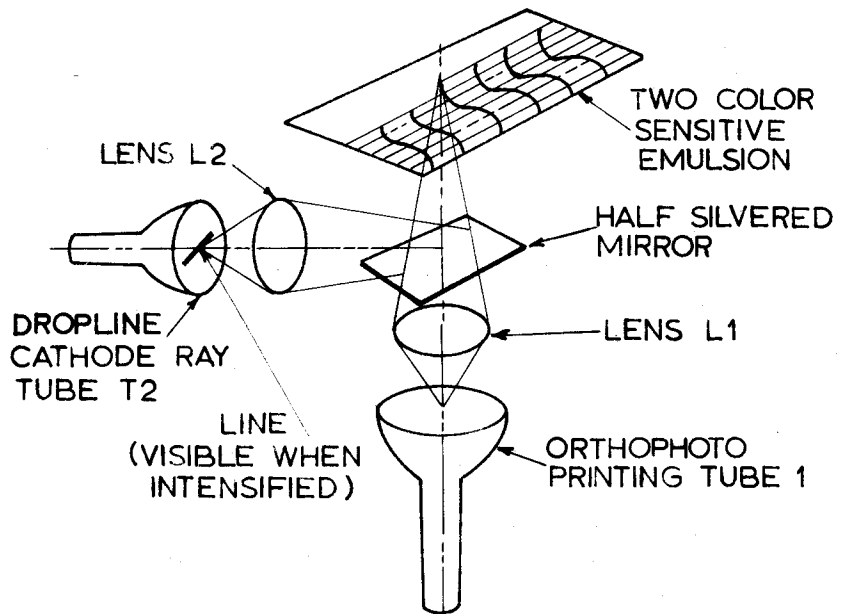

FIG. 6.4 STEREOMAT VI — SYSTEM ENABLING SIMULTANEOUS PRINTING OF ORTHOPHOTOGRAPHY AND DROP LINE CONTOURS.

with about 30 000 words of core memory. On this computer 100 photographs can be fully triangulated and adjusted in less than 2 hours at a cost of less than \$600. Larger computers should reduce this cost even further.

The programmes should be written in as general a manner as possible. While auxiliary data will provide values for exposure stations, exposure directions, or their co-ordinate and direction differences, and even heights for various terrain points, these data are not expected to be of the same or of a superior accuracy than can be expected from photogrammetric triangulation. It should therefore be possible to include auxiliary data, control points, photo-co-ordinate observations and any additional conditions (a lake has equal elevation) with appropriate weights into the adjustment. Such a programme already exists for a capacity of 100 photographs. It has been written by Raytheon/Autometric for the research agency of the U.S. Army. Another programme of even larger extent is being prepared by Dr. Schmid at the U.S. Coast and Geodetic Survey. The adjustment principle is that of observation equations with conditions.

The use of such a programme will permit the calculation of adjusted values for the orientation elements of a plotter to be used for the restitution. A careful plotter calibration may then eliminate the need for relative and absolute orientation procedures.

Returning to the problem of photogrammetric plotting, one finds that the individual functions to be performed are closely interrelated in the various phases of the process. Orientation requires selection, correlation, calculation and measurement, and the plotting of contours requires selection, correlation, calculation, measurement and plotting all at the same time. This is only possible in automated systems which are able to integrate most of the functions required. The exception remains the selection of control points and the interpretation of photographic information, which still has to be done by the operator.

3. Automatic Stereomapping Systems

All significant automatic stereomapping system developments are adequately described in the "Photogrammetric Engineering" issues of the last 10 years. Here it is only necessary to refer to the systems which have crystallized as potential production instruments.



FIGURE 6.5 Automatic Map Compilation System AMCS. Developed by Bunker Ramo division of Thompson - Ramo - Wooldridge under subcontract to GIMRADA.

The first in this category is the Stereomat - B8, an analog stereoplotter with automatic image correlation. It is the least expensive answer to the problem of automatic plotting. It costs about \$120 000. The versatility of a digital computation has been sacrificed for the lesser expense of a simple second order analog plotter. (Figure 6.3)

It has two cathode ray tubes generating blue light in a synchronous random scan pattern while the carriage moves in X or Y direction. The photomultiplier receives the blue light, which has been intensity-modulated by the diapositive and passes it on to the correlator. The viewing of the diapositive occurs in reverse order by use of yellow light and dichroic mirrors and filters. The random scan pattern can be used to determine X- and Y-parallaxes and thus the removal of Y-parallaxes may be used in an automatic relative orientation procedure. The X parallaxes control either the Z-movement in the profiling mode, or the X - Y movement in the contouring mode, for which a special scan arrangement is used in order to automatically determine the slope of the terrain. The output consists of an orthophoto, which is produced in the profiling mode. The new Stereomat VI model also has the provision to produce a contour plot onto the orthophoto. Whenever the Z passes a predetermined contour level a second CRT produces a line perpendicular to the direction of the slope which is mirrored onto the orthophoto. (Figure 6.4)

The stereomat can evaluate a complete model in about 2 hours including automatic relative orientation and operator controlled absolute orientation. During a working day an operator is therefore able to operate several instruments of this kind at one time, or he can be engaged in other preparatory and organizational work.

A more versatile, but also more costly system is the Universal Automatic Map Compilation Equipment (UNAMACE). It developed out of the prototype of the Automatic Map Compilation System. (Figure 6.5) Both instruments were designed by the Bunker Ramo division of Thompson-Ramo-Wooldridge, Glendale, California under subcontract to GIMRADA, the U.S. Army's photogrammetric research organization. The Unamace has a cost of about \$600 000.

It combines the versatility of an analytical plotter with the speed and convenience of an automatic image correlation system. It consists of 7 parts: a correlator, a digital computer, a viewer and 4 plotting tables, interchangeable in their functions. In the plotting procedure 2 tables are used to carry the diapositives; they are equipped with flying

spot scanners which feed the video signals to the correlator. The digital computer contains the photo-geometry in digital form and the correlator signal is used to change the digital values of height during the scan. The scan pattern is a modified TV scan with 128 lines per area element. The analog circuitry of the correlator permits to derive X- and Y-parallaxes, as well as slopes, out of the video signals. These are used to change the scan pattern, so that corresponding images are scanned, despite the perspective representation in the photographs. For production of the orthophoto and the dropline output undeformed scan patterns are used on the two other tables. (Figure 6.6) While the Stereomat B-8 operates on a similar principle, it does not make use of the scan pattern deformations in viewing: The Unamace also feeds the undeformed scan patterns of the two diapositive table flying spot scanners into the two cathode ray tubes of the viewer. It is therefore electronically possible to produce stereo-images for any type of image geometry. The Unamace has successfully been used to evaluate radar imagery, which is impossible to view stereoscopically without electronic image deformation. The viewing possibility is of course only of secondary importance for monitoring in an automatic system, as long as correlation is achieved.

The Unamace can also successfully be used for a more automated form of aerial triangulation. For this purpose up to 4 diapositives can be placed onto the plotting tables. When interior orientation is established by a simple procedure and when approximate photo co-ordinates of a control point or of a transfer point are fed into the digital computer, the system automatically brings this approximate location into the viewer. The measuring cross can manually be set onto the control point, the 3 corresponding photographs can be automatically correlated in sequence, and their co-ordinates read out. For image transfer it is not even necessary to select a transfer point, since the correlation is automatically carried out over an area, and since the subsequent analytical triangulation will determine exposure stations and exposure directions, which can be numerically introduced on most plotters.

Analytical plotters such as the Unamace only require this type of input in digital form. If this information is substituted by control point information, orientation procedures provide the necessary parameters. But even in this phase analytical plotters are more versatile. They can solve relative and absolute orientation in one effort in form of a double resection in space or they can utilize points lying outside of the stereoscopic coverage on one photograph for a space resection of one camera and a subsequent relative orientation of the second photo.

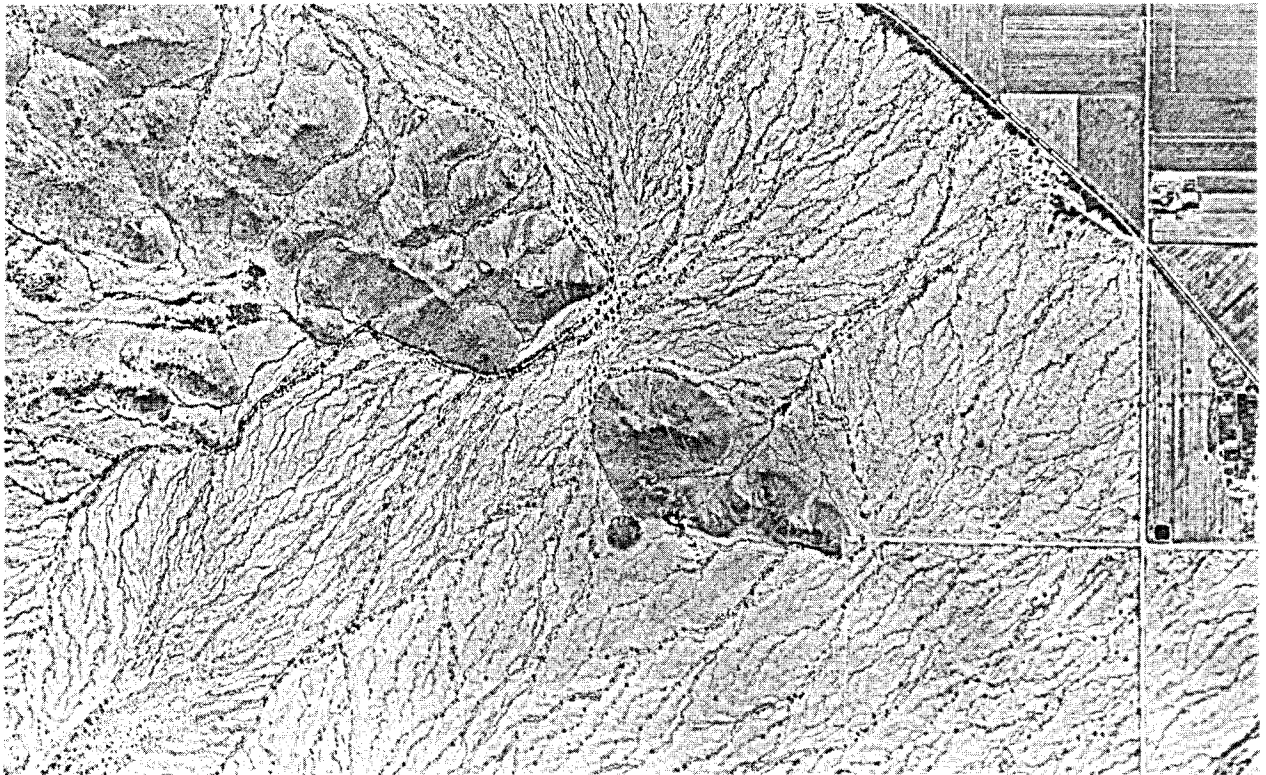
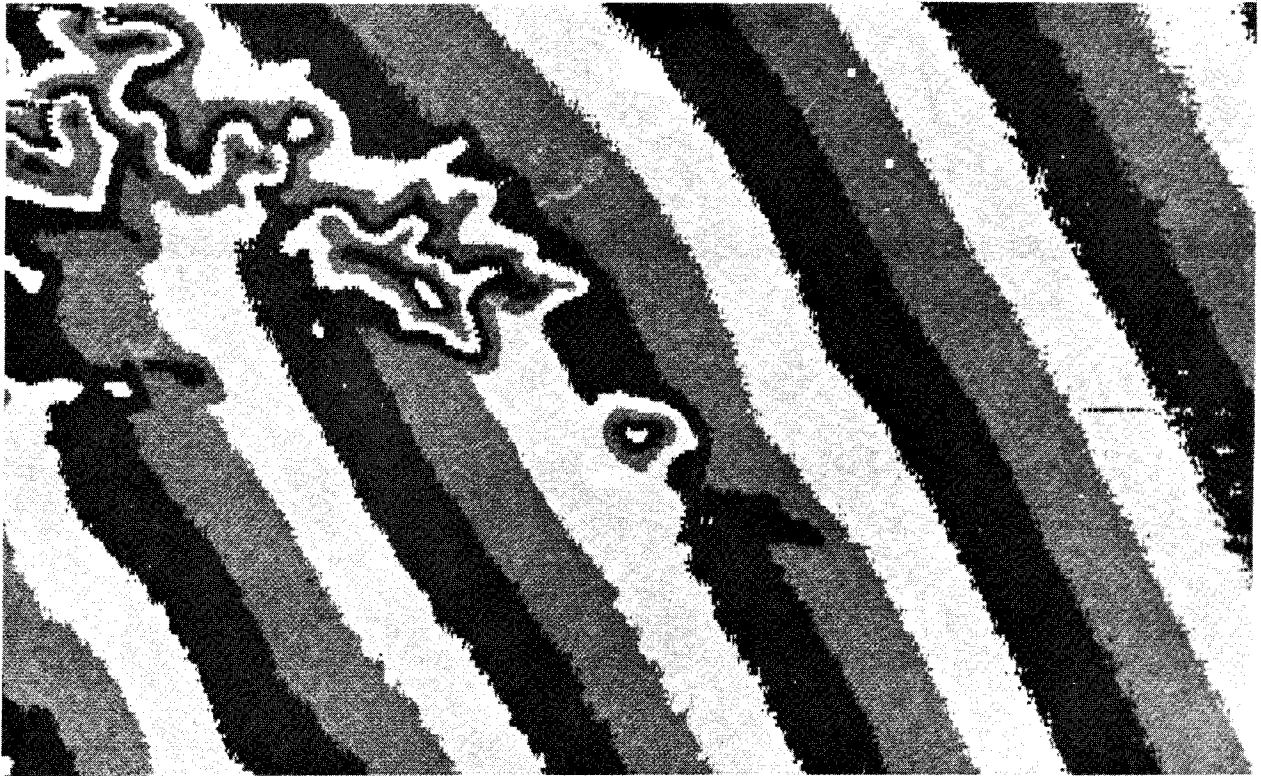

FIGURE 6.6 Drop line chart and ortho-photo compiled by UNAMACE.

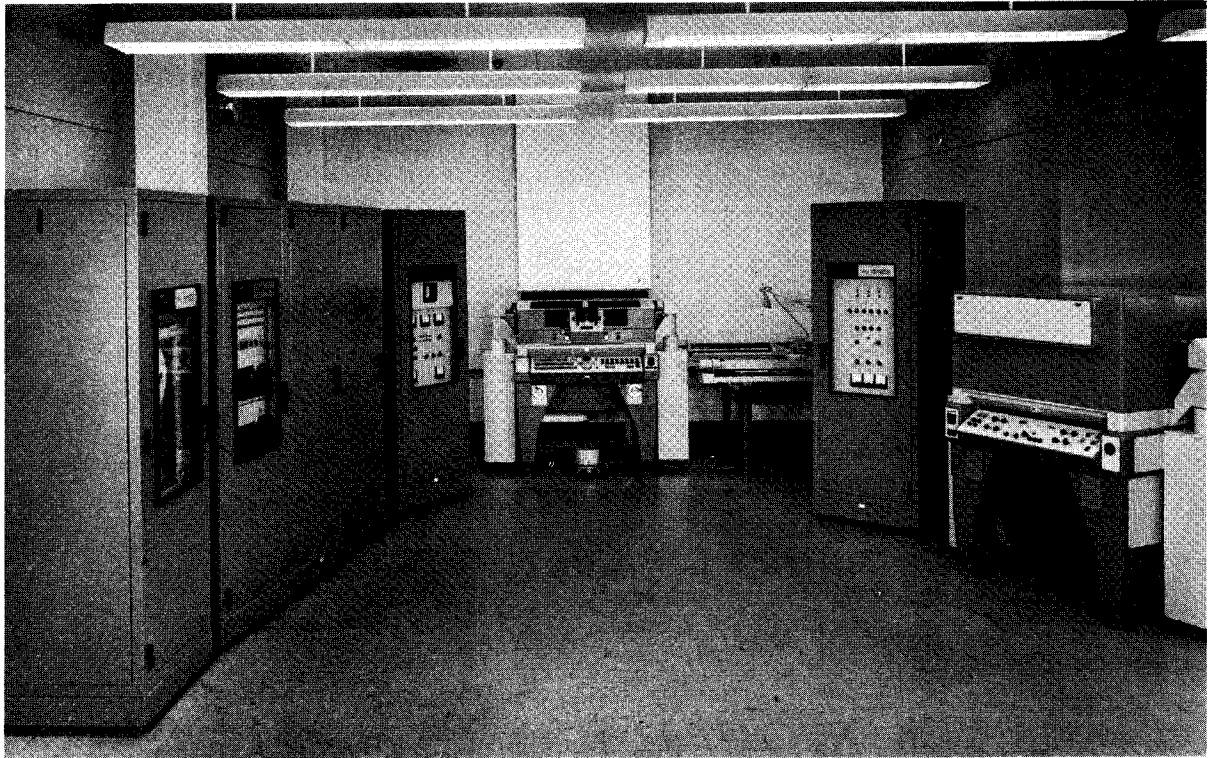

FIGURE 6.7 Automatic Analytical Plotter AS - IIC with orthophoto system. Developed by Bendix Research Laboratories in collaboration with OMI under sponsorship of U.S. Air Force Rome Air Development Centre.

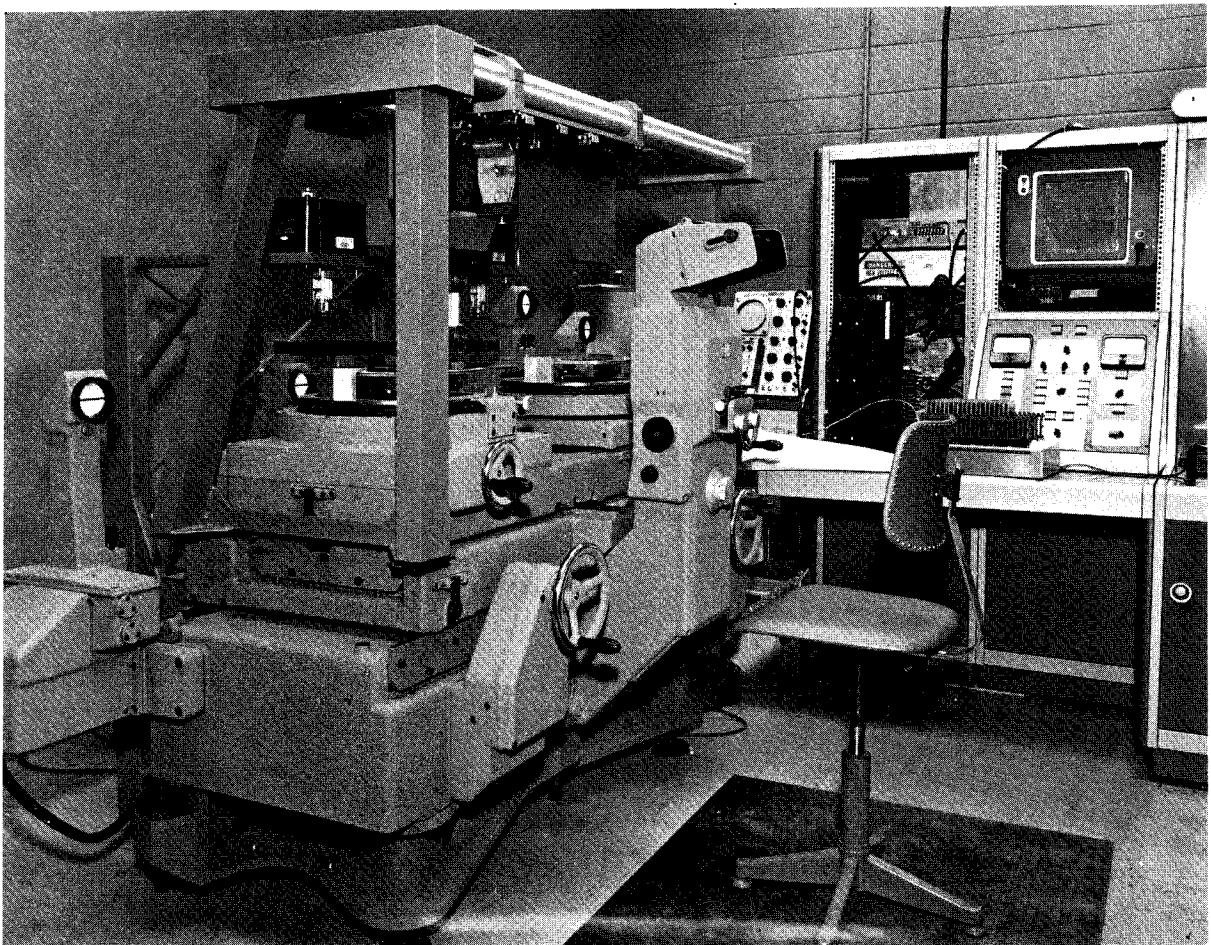

FIGURE 6.8 IBM Experimental Digital Automatic Map Compilation System based on Wild STK - 1 Stereocomparator.

The output possibilities can also be broadened in scope. While one table produces an orthophoto, the second table may be used to produce a dropline chart, or another orthophoto at a different scale, or even a new form of output: a product which in its Y - geometry corresponds to the orthophoto, but in which height differences are expressed by a parallax scale convenient for visual observation in conjunction with the orthophoto. Symbols may also be electronically inserted into the orthophoto output.

It is obvious, that the Unamace constitutes the most versatile photogrammetric plotting equipment of today.

A new automatic development for the U.S. Air Force, the Bendix - OMI Analytical Plotter AS-11-C (the automated version of the AP-2) operates on similar principles at about the same price, except that the viewing is carried out by an optical rather than an electronic system, and that the orthophoto and dropline outputs are not interchangeable with the diapositive holders as in the Unamace. (Figure 6.7)

The Bendix Corporation in Southfield, Michigan, as well as Bunker Ramo are presently engaged in the development of automatic systems on the analytical plotter principle which will be more attractive to the practical user in purchase price, but which will sacrifice some of the flexibility of the present systems.

A few other interesting developments have been carried out experimentally in the past. The Digital Automatic Map Compilation System, developed for GIMRADA proved that it is possible to digitize the information of a photograph and to continue further processing by digital computer. The digitizing equipment, which transformed a small photographic area element into one of 16 gray-scale values was attached to a Wild STK-1 stereocomparator. (Figure 6.8) The processing was done on the IBM 7094. The orthophoto was printed as a line sequence of dots with magnitudes varying according to the gray-scale values digitized. Contours were drawn digitally. The system was finally not considered to be a practical answer, because the digitization of photographic information into large resolution elements and only few gray-scale values means a drastic reduction of the information content of a photograph. (Figure 6.9)

Nevertheless, the thought offers great possibilities which can yet be developed: While correlation can best be accomplished by electronic analog procedures, it would be quite feasible to process the

correlated information by digital means in a much better way than this can be done today. A relatively crude example of digital processing consists in the recording of a digital terrain model and its further processing on the digital computer, as this has been done during the evaluations of Lunar Orbiter photography by aid of the Stereomat - B8 for the output of slope maps and altitude charts.

It is only necessary to improve the input-output facilities of the digital system in order to produce an off-line digital mapping system from a tape of correlated and referenced information. In such a way the cost of automatic systems may perhaps be substantially reduced.

4. Ultimate Automation

It is ultimately possible to change the entire process of photogrammetry to produce a more complete automation of mapping techniques. While such thoughts are so far nothing more than ideas, some of these have already been expressed in great detail. Paul Rosenberg envisions a system of "electronic photogrammetry" in which the terrain information is gathered by electronic scanners (7). The digitized signals are later processed by computing techniques. Such principles are already applied for imagery systems other than in the visible or near-visible range, and when vidicon images or photographs cannot be recovered and have to be transmitted, as is the case from the Moon, Mars or Venus to earth.

It is likewise also possible to consider the evaluated digital terrain information as an end product on magnetic tape. Such a "digital map" can be stored economically and interrogated at will for the desired information in form of a visual output or a dimensioned quantity. Automation can therefore still be carried very far from its present status.

5. Conclusion

While the development of photogrammetric automation is constantly going on, the practical photogrammetrist must assess its use for present day production. This assessment must be made with the following background in mind:

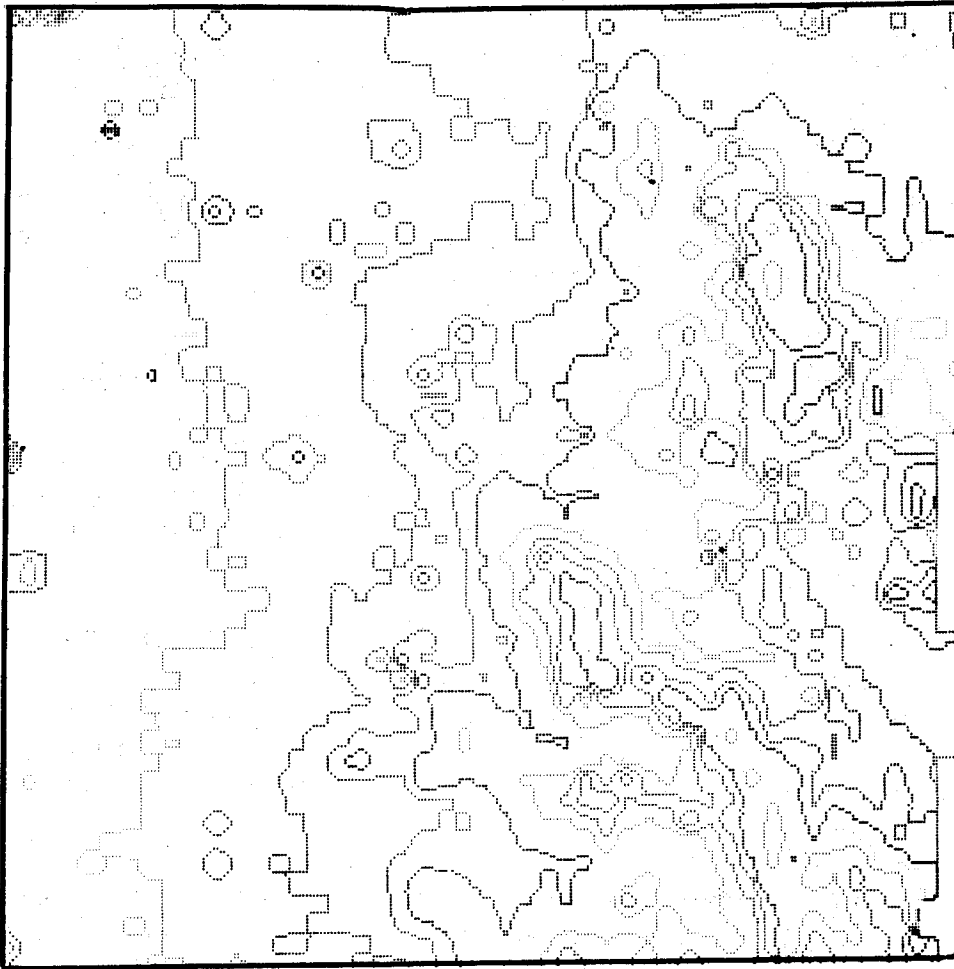

FIGURE 6.9. Contour output from IBM Digital Automatic Map Compilation System.

Figure 6B. CONTOUR MAP PRODUCED BY THE PREDICTIVE SYSTEM II

With the exception of the original Stereomat I all automatic developments were financed by U.S. defence funds. There were to enable mapping procedures of very large areas in the shortest possible time. They were to have the versatility to evaluate imagery of varying type and quality. The economic factor was of secondary importance.

On the other hand it was by these efforts that development costs could be absorbed, and photogrammetrists the world over have now the advantage of tested systems, which are capable of operating at a 10 times higher speed than the human operator.

The photogrammetrist, thinking in economic terms, is already able to justify the use of automatic systems if his work load is sufficiently high. The real importance of automatic systems will be brought about, if it can be demonstrated that automatic photogrammetry will make the mapping process as such more economical, and when consequently more mapping will be considered necessary.

Practical photogrammetry will have to assess the different systems according to equipment cost, amortization, cost and quality of labour, productivity, downtime and the environment required. Far reaching decisions in the organization of photogrammetric establishments will also be necessary, if automatic systems are to be integrated into present production.

The academic approach should be not to take a stand for or against the application of presently developed automatic systems without having had the opportunity to familiarize oneself farther and deeper with the elements of photogrammetric automation by actual contact, study, research and development so that a clearer understanding of the phenomenal photogrammetric development of the last decade becomes possible.

References:

- (1) R.M. Centner and C.W. Matherly. Automatic Pass - Point Selection . Photogrammetric Engineering, 1966, pp. 834-841.
- (2) E.R. Demeter. Automatic Point Identification Marking and Measuring Instrument . Photogrammetric Engineering, 1962, p. 82.

- (3) J. Lentz and R. Bennet. Automatic Measurement of Star Positions .
Electronics, June 1954.
- (4) A. Rosenfeld. Automatic Recognition of Basic Terrain Types from
Aerial Photographs . Photogrammetric Engineering, 1962.
- (5) A. Goldstein and A. Rosenfeld. Optical Correlation for Terrain
Type Discrimination . Photogrammetric Engineering, 1965.
- (6) J. Hawkins and C. Munsey. Automatic Photo Reading .
Photogrammetric Engineering, 1965.
- (7) P. Rosenberg. Information Theory and Electronic Photogrammetry .
Photogrammetric Engineering, 1955, p. 543.

DISCUSSION ON PAPER NO. 6.

Chairman: Major W. Child, Royal Australian Survey Corps.

CHAIRMAN: I feel that no organisation in Australia is ready for automated photogrammetric equipment at the moment. The U.S. developments are based on military requirements which do not match our normal mapping requirements. The manufacturers are not yet in a position to provide satisfactory servicing, which is very important in new electronic equipment. They are extremely expensive and their accommodation and the organisation necessary to ensure a sufficient work flow will cause problems.

J.D. LINES: I agree with most of the points made by the chairman. Nevertheless a start must be made somewhere and National Mapping is committed to the purchase of an automated plotter. The one chosen, the Wild B8-Stereomat IV will cost \$125 000 plus \$35 000 for the digital output, giving a total of \$160 000. We intend to familiarize ourselves with the equipment and to assess the capabilities before committing ourselves further.

We have had experience of the maintenance problem, with the Aerodist equipment. However the purchase of the Stereomat equipment was negotiated to include a two-year maintenance contract.

Is the work load sufficiently high? Yes, on the 1/100 000 mapping programme there is more than sufficient mapping to keep the instrument busy. To make it pay, two shifts per day must be worked.

The problem of accommodation has been solved. The floor must be reasonably strong and the structure stable, and of course the area must be air conditioned.

D.R. HOCKING: Can the speaker give some idea of the reliability of the automated equipment, particularly the B8-Stereomat with regard to maintenance of production rate?

KONECNY: The problems encountered are mainly those of getting the digital equipment working. In my experience at NASA, a representative was on hand twice a week to deal with breakdowns and routine checks. After about six months most problems had been ironed out and the down time was insignificant.

W.B.R. SMITH: Professor v. d. Weele drew a distinction between mechanisation and automation. He defined mechanisation as that part of instrumentation which replaces human manipulations, while automation replaces human judgement with instrumental decisions.

Can the speaker indicate the extent to which digital terrain information is used for engineering (principally road) purposes in the U.S. and Canada?

KONECNY: Most highway departments in the United States use digital equipment which digitizes cross-sections. This equipment is normally attached to Balplex or Kelsh instruments. Besides the work described in the paper by IBM, now discontinued, a digitized model has been developed by the Massachusetts Institute of Technology. I do not know whether it has been tested in practice yet.

K. LEPPERT: How does the drop line method of height representation work? Must the whole of the model be scanned for one contour or are all contours determined during one scan?

KONECNY: The contours are produced in one scan in the same profiling mode as the orthophoto. Every time the scanner crosses a contour a drop line with appropriate orientation is printed.

HOCKING: When the B8-Stereomat is set for contouring, the time taken for one model is seven hours. The drop line chart plus orthophoto takes two hours.

In view of the striking quality of recent lunar photographs using video technique, can KONECNY say whether the resolution using video will approach optical resolution in the near future or what proportion, video to optical resolution, can be expected?

KONECNY: This is a problem in the field of electronics. It depends mainly on the width of the spot scanner. The best which it can achieve at present is 20 lines/mm. whereas photography has a resolution of 50 lines/mm. or better. In magnifying the photograph to produce the orthophoto, this resolution will drop further. With automation scanning is along parallel strips. The finite width of these strips causes jumps at the edges of adjacent strips, in following a particular object.

PAPER NO. 7.

PROBLEMS ENCOUNTERED IN THE USE OF THIRD ORDER

LEVELLING FOR THE NATIONAL LEVELLING GRID.

By K. Leppert, Division of National Mapping.

The following notes have been prepared for the Colloquim on Control for Mapping to be held at the University of New South Wales in May 1967.

Control Levelling Activities in Australia.

Control Levelling in this paper is understood to be Levelling of High Precision, Precision Levelling and Third Order Levelling as defined by the National Mapping Council. Its purpose is to provide a framework of levelling traverses along roads, railways and tracks with permanent bench marks placed at certain intervals. The heights of these marks are obtained by means of geometric (differential) Levelling in reference to a datum mark which is usually related to mean sea level of a certain period at the main tidal gauging station of the State.

Before 1956 some 3,000 miles of control levelling had been completed in three States of the Commonwealth. Between 1956 and 1960 an additional 10,000 miles were levelled and by the end of 1966 the total amount of control levelling had reached 80,000 miles covering the continent and Tasmania. An adjustment of the levelling survey is planned for 1970 by which time over 100,000 miles of control levelling will be completed. (See diagram)

The Levelling Survey of Australia forms loops of between 300 to 1,000 miles in circumference. Its main purpose is to provide control heights for topographical mapping. Within loops lower order levelling or other survey methods are being employed to provide vertical control for photogrammetric stereo models. (Other methods : Trigonometric heighting, barometric methods, Automatic Profile Recording, Levelling with Johnson Elevation Meter.)

The decision to observe the major part of the levelling net to third order standards was made by Commonwealth Authorities who were faced with an urgent requirement for levelled heights in connection with mapping and gravity surveys.

The levelling net is going to provide heights sufficiently accurate for all practical purposes. An analysis of the misclosure of 112 loops with an average length of 320 miles yields a standard error of ± 0.036 feet for 1 mile of levelling. On this basis it should be possible to determine the height of a bench mark in the centre of this continent with a standard error of ± 1.2 feet.

The National Mapping Council of Australia has laid down accuracy requirements (1) for the following classes of levelling:-

1. Special High Precision Levelling.
2. Precision Levelling.
3. Third Order Levelling.

Accuracy requirements for 1 and 2 are as specified by the International Association of Geodesy. For field observations certain check conditions apply. These refer to the allowable difference of the forward and backward runs of a section between permanent bench marks which are M miles apart as well as to the allowable misclosure of circuits of M miles in Circumference. (In both cases M is measured along the levelling route.)







These requirements are:

Special High Precision	$0.017 \sqrt{M}$ feet
Precision	$.035 \sqrt{M}$ "
Third Order	$.05 \sqrt{M}$ "



AUSTRALIA
 NATIONAL LEVELLING SURVEY

AS AT MARCH 1967

-  First Order Levelling completed or in hand
-  Second Order Levelling completed or in hand
-  Third Order Levelling completed or in hand
-  Third Order bench marking completed or in hand
-  Third Order proposed 1st priority
-  Third Order proposed 2nd priority
-  Tide Gauges

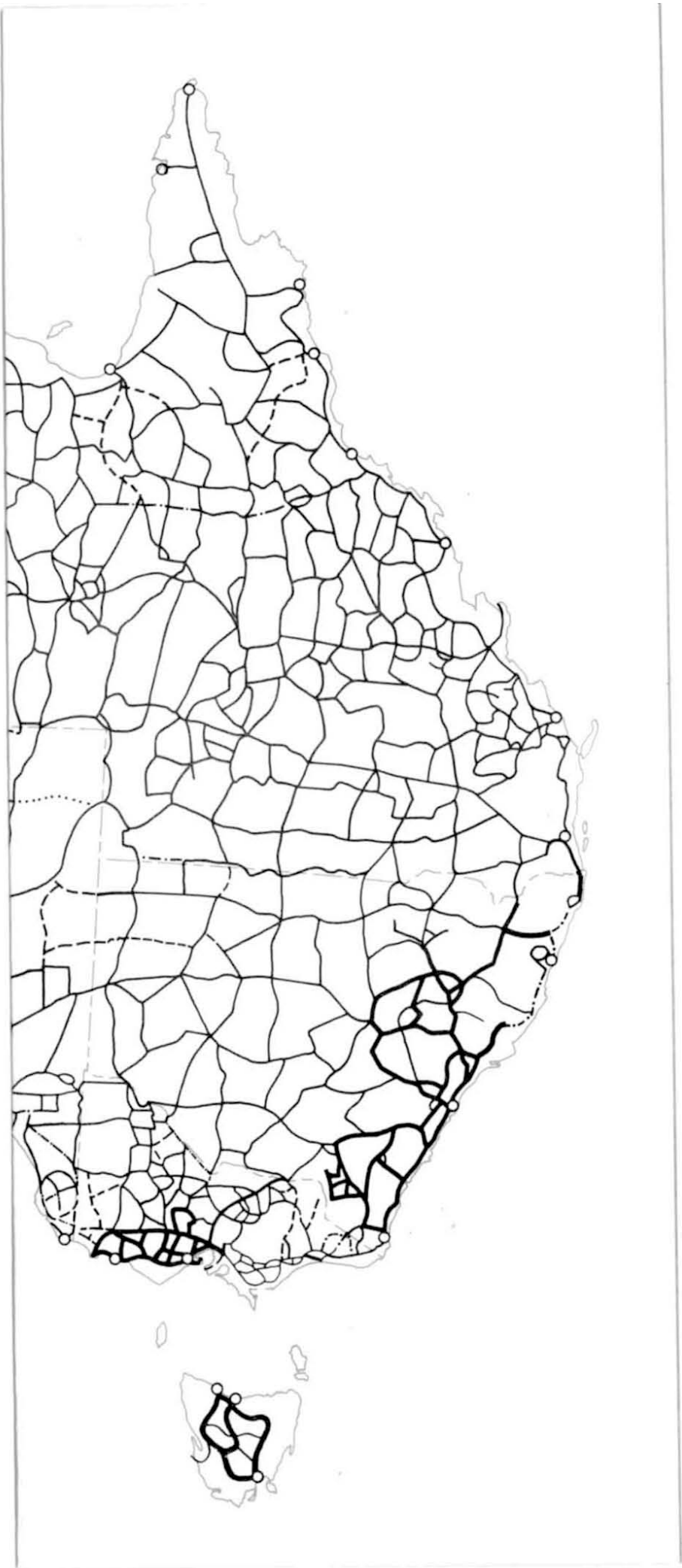

To the end of 1966 progress in the 3 classes of control levelling in Australia was as follows:

Special High Precision and Precision

by State Lands Department and Statutory Authorities		Miles
		5,500 miles 6.7 ^o /o

Third Order Levelling

by Lands Departments	16,100)	
)	
by private Surveyors for Department of National Development	26,300)	51.7 ^o /o

One Way Third Order Levelling

with dual faced staves by

Department of Interior for the

Bureau of Mineral Resources	34,100	41.6 ^o /o
-----------------------------	--------	----------------------

Total	<u>82,000</u>	
-------	---------------	--

Here are some of our problems associated with third order levelling as the title of these notes suggests

Levelling Instruments

All third order levelling in Australia is observed with automatic levels. In the early sixties rather large section misclosures in two way levelling and loop misclosures in one way levelling occurred before the influence of a systematic error in the compensating mechanism of automatic levels had been recognized.

I refer to the error caused by an imperfect rectification of the line of sight also known as "oblique horizon". This error occurs only when the circular buble of an automatic level is not in perfect adjustment which unfortunately it never is. The effect of the oblique horizon can be rendered ineffective over two consecutive setups if the circular bubble is in good

adjustment and by using the "unsystematic procedure of levelling" with equal sighting distances. The oblique horizon of the compensator of an automatic level is not constant. It changes with a change of the residual adjustment error of the circular bubble and with a factory adjustment of the c factor of the compensator.

Other systematic errors are feared to cause misclosures just outside the allowable limit in sections of 50 miles and more in length. Hysteresis in compensators as described by D.F. Schellens (2) and M. Drodofsky (3) may occur in automatic levels and especially in those which have the compensator mounted away from the centre of rotation of the telescope, mostly near the ocular lens.

Hysteresis in the compensator can be compared with "Black Lash" in micrometers or the "Lag Error" in a spirit level.

The effect of hysteresis depends on the direction from which the compensator moves to its rest position. This is either from the stop on the eyepiece side of the compensator or from the stop on the opposite side, the objective side.

In all automatic levels which do not have the compensator mounted in the centre of rotation of the instrument the compensator will deflect away from this centre when the instrument is rotated. This is caused by centrifugal force.

After every rotation the compensator returns to its rest position from the same direction, provided of course the instrument had been levelled up before hand.

The effect of hysteresis on readings preceded by a rotary motion of the instrument is equivalent to a constant collimation error.

In our system of levelling (unsystematic procedure) one out of every four readings is not preceded by a rotation of the telescope. There is an equal chance that the compensator moves from either stop to its rest position at this one out of four readings. That means that over four instrument set ups with 8 readings one reading will occur (a back sight reading) at which the compensator moves to its rest position from a direction opposite to that of the other 7 readings. It is this reading we are concerned about.

If the telescope is rotated after the instrument has been levelled then every reading of the 8 readings in 4 set ups is preceded by a rotation and the effect of hysteresis is equivalent to a constant collimation error.

A constant collimation error of any reasonably magnitude is eliminated provided equal sighting distances are taken or the sum of the backsight distances balance the sum of the foresight distances in a section.

It could be argued that not all automatic levels are subject to hysteresis especially not the telescopic type ones. This may be so, however, it is thought that the little work involved in rotating the telescope of any type of automatic level to and fro is justified in order to establish a strict observing routine.

An additional benefit of this routine is that a sticky compensator is dislodged before every reading.

The National Mapping Council has adopted a recommendation which lays down a strict observing procedure designed to minimise the effect of compensator errors.

The problem is how to make sure that surveyors engaged in the levelling survey stick to the recommended practices. It is a matter of education and I think that the Universities can play an important part here.

Levelling Staves

Wooden levelling staves of the folding type manufactured by Wild and Watts are mainly used in third order levelling. Interior uses the telescopic type dual faced staff and in Western Australia some aluminium staves are used.

For levelling contracts folding staves calibrated in the capital of the State they are to be used in are issued to contract surveyors and on completion of the contract are recalibrated. The calibration consists of comparing a number of staff intervals with a standard. The scale factor of the

staff

$$c = \frac{\text{Sum of Actual Lengths of Intervals}}{\text{Sum of Nominal Lengths of Intervals}}$$

is obtained. From the standard deviation of the observations and from the estimated setting accuracy of the measuring scale the random graduation error of the staff is computed. This gives us a measure of the quality of the staff.

E.G. Thwaite of the Standards Laboratory C.S.I.R.O. (4) has described a staff calibration procedure based on the comparison of random staff intervals. He recommends that the random staff graduation error should not exceed + .001 ft. for 3rd order staves. All of the Wild and Watts staves checked by National Mapping so far have a smaller random graduation error.

Prior to the National Levelling adjustment it is intended to correct differences in elevation by multiplication with the combined scale factor of the pair of staves which have been used in the observation.

Although we require the recording of dry temperatures during the 3rd order levelling observations a temperature correction will not be applied to the observed quantities. The coefficient of thermal expansion of European Red Pine (Wild staves) is about 2×10^{-6} per degree Fahrenheit. A difference in elevation of 100 feet levelled at a temperature of 100°F with wooden staves calibrated at 70°F will be measured too short by 0.006 ft. We are prepared to ignore this.

We do not attempt to determine the changes of moisture content in wooden staves, although these are likely to occur inspite of protective coats of paint and varnish. Staves are withdrawn from control levelling activities after two or three field seasons or before when badly chipped.

Short term variation in humidity are believed to have only a small effect on the moisture content of wood and even less on painted or varnished wood.

The change in length of wood whose fibres run longitudinally due to a change of 1% of moisture contents is about 0.007%. Moisture contents of

wood when unseasoned is about 30^o/o, when kiln dried it may approach 0^o/o. According to investigations carried out by the Lands Department of Queensland the annual average moisture content of wood in Brisbane is 14^o/o that in the western Queensland about 8^o/o.

As stated before the change in moisture content is a slow process especially in painted wood. Its effect on the length of a staff can be taken care of to a great extent by recalibration of the staff within a short time after its return from the field.

Marking and photo identification

In stable ground the conventional type of marks are placed at intervals varying from 1 to 4 miles according to the practice of the survey authority.

In unstable ground deep bench marks are emplaced. They may consist of 3/8" brass rod or galvanised iron pipes of up to 12 feet in length set in concrete at the bottom of a hole 4 to 6 inches in diameter. The remainder of the hole is filled with loose gravel or sand. At ground level a concrete collar is slipped over the rod or pipe. This type of mark is used extensively in South Australia and the eastern parts of Western Australia. Clusters of 3 bench marks 200 to 300 feet apart at intervals of 50 to 100 miles or on the edges of large areas of unstable ground are being placed in Queensland and the Northern Territory. In South Australia it is the practice to place clusters of 3 marks at intervals of 12 miles.

In general we have very little trouble with damage or loss of marks attributed to natural causes. It is people seeming to enjoy destruction who are responsible for almost all the damage or disappearance of marks.

Control level bench marks in South Australia are identified on air-photos. Most of them have been premarked on the ground often rather permanently and later on photographed with a RC 8 camera on special sorties. All bench marks levelled by the Department of Interior are identified on existing aerial photographs by pin pricking. Bench marks placed in the eastern part of Western Australia and in the Northern Territory for third order contract levelling will be premarked on the ground at the time they are placed. This marking consists of a ring of stones 12 feet in diameter painted white or a

circular trench of the same diameter. Special flights will be organised in order to photograph these marks. In the office the position of the bench marks will then be transferred to the mapping photography with the aid of a differential stereoscope.

One of the jobs of the recently established Levelling Section in National Mapping will be to connect trig and traverse stations of the National Geodetic Survey to the levelling net at intervals of about 100 miles. This will be done systematically by 250,000 sheet areas and while in the area levelling parties will photo identify all bench marks in this area which had not been identified before.

Tide Gauges.

As part of Australia's 10 year mapping programme the Division of National Mapping on behalf of the National Mapping Council and with the help of various State and other Authorities is organising a programme of tidal readings at 33 tide gauge stations around the coastline of Australia, (see diagram).

The aim of this programme is to obtain simultaneous recordings at all stations on a continuous basis for a period of one year in order to compute mean sea level at these stations pertaining to the same epoch.

The processing and analysing of the tide record charts is being undertaken by the Horace Lamb Centre for Oceanographic Research of the Flinders University in Adelaide. Hourly values are read from the charts to the nearest 0.1 ft. and punched onto cards. All records are digitised in Universal Time. There is a card per day for each station with 24 tide readings on the hour (UT).

During the first twelve months of the programme which started on 1st January 1966 twenty-four stations have supplied their records for digitising. The programme is to continue for at least one more year in order to get records from as many stations as possible for the same period of 12 months.

National mapping is sending a survey team to visit each tide gauge. The team's job will be to calibrate the tide gauge recorder against a standard instrument to establish additional permanent marks so that there are at least 3 near every tide gauge and to level the difference in height between the

staff gauge and the permanent marks as well as to take photographs of all important fixtures of the tide station.

Adjustment of the National Levelling Survey.

An adjustment of selected loops of the continental net is to take place in 1970. Observed orthometric differences based on theoretical gravity will no doubt be used.

The biggest problem will be to obtain the necessary abstracts of the levelling which is to be included in the adjustment showing all pertinent information free from clerical errors. National Mapping is working on the design of an appropriate data sheet which provides for all necessary information. It is to be filled in by the survey authority which holds the field level books. Certain columns of the form are spaced in the fashion of computer data sheets and information in these columns is meant for punching on cards without further transcription.

The method of adjustment has not been determined yet. However it seems pretty certain that the levelling net will have to be split in more than 2 parts whatever method will be used. There are several ways of dealing with the mean sea level data of the tidal stations in the adjustment. I will mention just two. (A) We can hold all msl values at zero and adjust the whole net to them. This method would be based on the theory that mean sea level is an equipotential surface coinciding with the geoid. It is not hard to define such a datum surface, it is a different matter to accurately determine this surface at the tidal stations.

Oceanographers have long ago come to the conclusion that many of the forces which have a bearing on the height of tides are not periodic in nature. Winds, barometric pressure variations, ocean currents, variations in the density of the sea water and under-water topography near stations give reasons to believe that mean sea level determined at widely separated stations from the hourly readings of the same period does not represent the same equipotential surface. This gives weight to the following approach. (B) We can hold one arbitrary datum point fixed somewhere in the centre of Australia and adjust the whole net disregarding mean sea level at the tide gauges. There will be differences at the tide gauges between the arbitrarily adjusted values and the theoretical zero values of mean sea level. A block shift can now be applied

to the whole net the amount of which can be determined by least squares with the condition that the sum of the squares of the remaining differences be a minimum. Either solution may be acceptable and may lead to the determination of a National Height Datum.

Levelling traverses not included in the adjustment will be tied to adjusted B.M.'s. Finally all trig heights along traverses and chains of triangulation of the Australian Geodetic Survey will be re-adjusted in terms of the National Height Datum.

Bibliography

- (1) National Mapping Council of Australia : "Standard Specification and Recommended Practices for Horizontal and Vertical Control Surveys". Prepared on behalf of the National Mapping Council of Australia by the Director of National Mapping, Division of National Mapping, Department of National Development, Canberra, A.C.T., April 1967.
- (2) D.F. Schellens : "Design and application of automatic levels." Canadian Surveyor Vol. XIX, June 1965, No. 2.
- (3) M. Drodofsky : "Consistently positive closing errors in first order levelling." Zeiss Information No. 56.
- (4) E.G. Thwaite : "Calibration of precise levelling staffs by a procedure involving a random selection of intervals." National Standards Laboratory, Division of Metrology M.I.R. 1960, April 1958.
E.G. Thwaite: "Accuracy of staff calibrations to meet National Mapping requirements." National Standards Laboratory, Division of Applied Physics, M.I.R. 1130, September 1962.

PAPER NO. 8

LEVELLING IN NEW SOUTH WALES SINCE WORLD WAR II

by

P. Seidel

Abstract. After some general remarks on mapping control the paper deals with height control, standard datum and the development of precise and third-order levelling by the Central Mapping Authority of New South Wales.

1. Need for Mapping

This colloquium is concerned with mapping control, therefore I may be permitted to make a few remarks on mapping generally.

The prosperity and the state of development of a country depend on a number of factors which cannot be neglected without producing serious consequences. One of these important factors is the existence and availability of reliable maps.

A reliable map is the final product on which all further development is based in respect to, among others, : engineering projects, problems concerning land usage, forestry, soil and water conservation, mineral resources and military requirements.

The first requirement for the construction of accurate topographic maps or of any accurate map is the provision of a firm foundation on which such can be based. This is a well conceived and carefully measured triangulation and height system.

Before the Central Mapping Authority was established in N.S.W. the then Premier directed in 1945 that a committee be appointed to investigate the position in regard to the mapping requirements of Government Departments and Instrumentalities. This committee was also to review the existing compilations of the Department of Lands. It found that "notwithstanding that mapping had been a function of the State for more than a century, there are now in N.S.W. few maps of sufficient accuracy to serve as a framework on which modern maps could be compiled". This condition was attributed to the lack of sufficient trigonometrical control, and other reasons.

The activities of the Trigonometrical Survey Division of the Central Mapping Authority are now mainly concerned with providing this necessary framework and control data for compilation of maps from aerial photographs.

2. Mapping Control

When a map is compiled by photogrammetric means a number of control points are required for horizontal and vertical control. These requirements are conveyed to field officers who effect the necessary measurements in the field for computation of co-ordinates and heights.

To reach satisfactory height accuracy, as many trigonometrical stations as possible are connected by levelling. Reciprocal vertical observations in the trigonometrical network improve the accuracy and reliability. Control points required, which are not Trigonometrical Stations, are established by resection or by radiation and vertical observations. In areas where only unreliable heights are available levelling is necessary to provide sufficient data to control the map. Third-order levelling, barometric levelling, altimetry or the elevation meter may be used for this purpose.

When the map is drawn by the Cartographic Division, Field-completion action follows to add detail, edit and assign names to the map. This stage is combined with a test of the accuracy of the compilation - the comparison of field and map horizontal positions and of elevation at selected points. Elevation is to be determined at four occupied points for each field-sheet (15' by 7½' at scale of 1:31680). Test elevations must be correct within 5 feet in terms of the datum of

elevations used in the mapping. Checks are also made from these test points to other features on the compilation to ensure the accuracy of the elevation to within half the contour interval. The four test points should be away from other height control and well distributed over the field-sheet.

3. Precise Levelling

General Remarks. In order to compare the precise levelling systems of different countries, and to connect State-wide levelling nets, International standards and regulations have been adopted to define what constitutes precise levelling. As early as 1867 at the Second International Conference for Geodesy, regulations were laid down stressing that the staves employed in precise levelling should be calibrated and investigated for graduation error. They should be kept vertical by some means. Levelling lines should be run in circuit. The probable error of two adjoining points approximately one kilometre apart should not be greater than 3mm. and in no case greater than 5 mm. Standard datum for every country should be established in a geologically suitable area.

Owing to the rapid increase in the precision of levelling new specifications were adopted in 1912. Here levelling of high precision (as against precise levelling) was defined as: every line, set of lines, or net which is run twice, in opposite directions, on different dates as far as possible, and the errors, accidental and systematic, computed according to uniformly adopted rules should not exceed ± 1 mm. per km. for the probable accidental error and ± 0.2 mm. per km. for the probable systematic error.

In further conferences of the International Association of Geodesy 1936 in Edinburgh, 1948 in Oslo, 1951 in Bruxelles and 1954 in Rome, new regulations were drawn up specifying the requirements for precise levelling. e.g. the instruments used should have a magnification of 30 to 40 times. The spirit level vial should have a radius of 40 to 100 metres which is equal to a sensitivity of 10 to 4 seconds of arc per 2mm. run. The graduation of the staves should be done on an invar strip. And again new formulae for the evaluation of errors were accepted. Some of these formulae are still disputed.

Datum. The height of a point means little unless the datum to which it refers is also stated. A number of Government Departments in N.S.W. carry out levelling, and in the past they each referred their heights to datums which were convenient to their own specific purposes. To enable these heights to be easily compared a conference was called in 1897 to discuss the adoption of a uniform datum. This conference decided to recommend Mean Sea Level as Standard Datum, though everyone was aware of the difficulties some Departments would have to face and of the fact that Mean Sea Level is not the same for all points along the coast. A sub-committee was appointed to investigate the matter and as a result of its report the value of the plug at the Bridge Street entrance of the Lands Department building was taken as being 28.94 feet above Mean Sea Level as measured on Fort Denison Tide Gauge. The term Standard Datum became law.

The conference also adopted a resolution that it was desirable to have more automatic tide gauges established along the coast.

In this connection it might be interesting to look into the different levellings which have been carried out to connect the Lands Department Plug to Mean Sea Level. There have been 10 levellings between 1882 and 1953. The results vary but indicate the wisdom of selecting a permanent value for the originating Bench Mark. They all refer to the same value for Mean Sea Level, i.e. 2.525 ft. above the zero of Fort Denison tide gauge, as adopted in the evaluation of Standard Datum.

Benchmarks. The only visible signs of levelling are the benchmarks and much care must be taken in securing the most stable positions for these marks. They are either: Permanent Marks, State Survey Marks or Pipe Bench Marks as specified in the Survey Co-ordination Regulations. These marks are placed substantially ahead of the levelling to allow time to consolidate. They are approximately one mile apart.

Metropolitan Levelling. Precise levelling to National Mapping Standards on a State-wide coverage is comparatively new to Australia. Within the Central Mapping Authority it was started in 1953.

General Description:

1. Special High Precision levelling shall normally be of very limited extent and be specifically undertaken for purposes where the utmost precision is required.

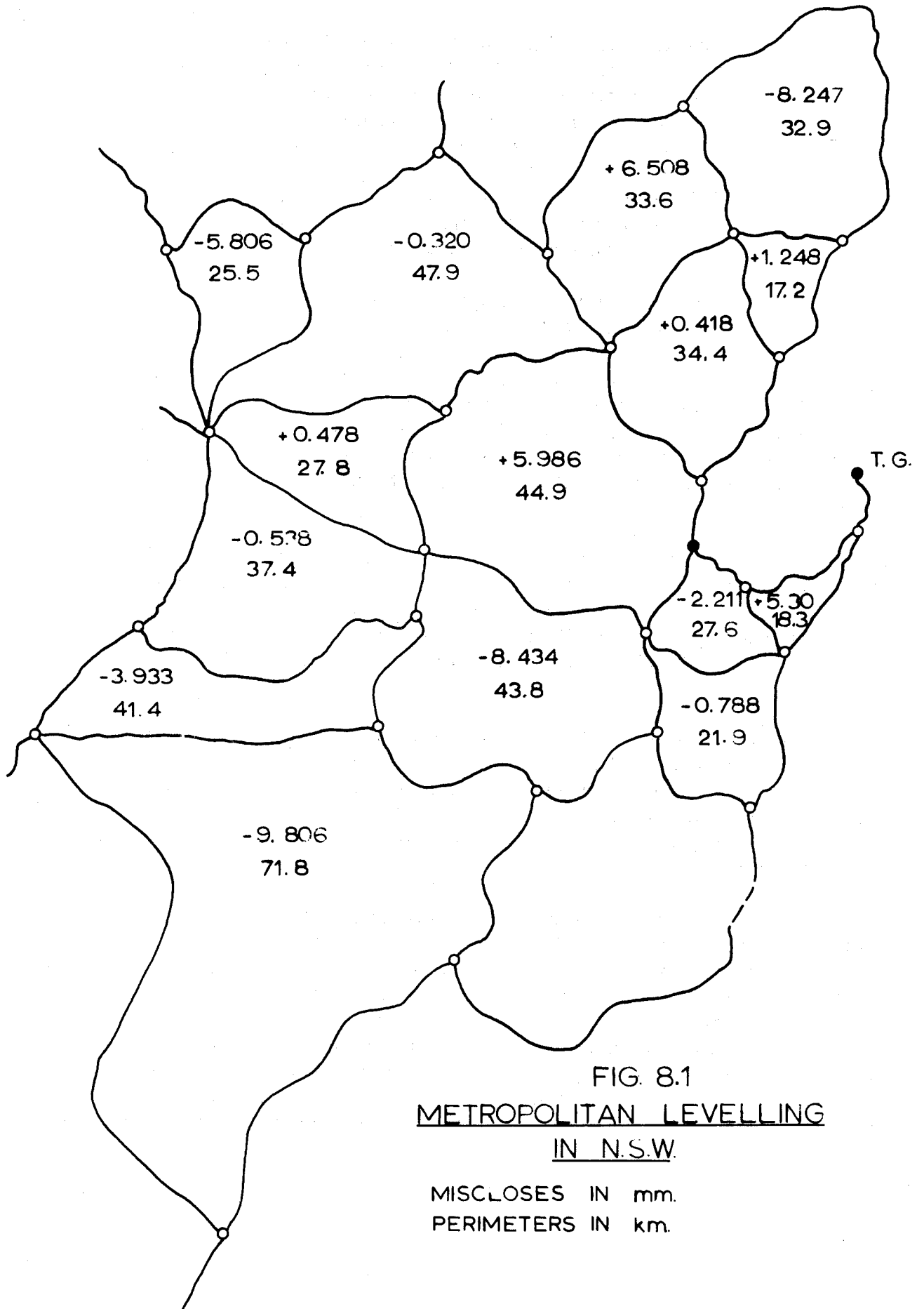

FIG. 8.1
METROPOLITAN LEVELLING
IN N.S.W.

MISCLOSES IN mm.
PERIMETERS IN km.

2. Precision levelling shall normally be executed between permanently marked stations along lines as approved from time to time by the National Mapping Council, and for the extension from these lines to provide a fundamental network of stations over the entire area to be controlled.
3. Third-order levelling shall normally be used in subdividing grids of precision levelling at intervals appropriate to local conditions in the area to be controlled.
4. Fourth-order levelling shall be carried out with sufficient accuracy to control the contouring of the area to be mapped.

Levelling commenced in the Sydney Metropolitan area and a network of 17 circuits was established between 1953 and 1956. Only one observer was engaged here at this time. The equipment used was a Wild N III level and two one-piece invar staves of 3 metre length graduated in centimetres with two different graduations on the same strip.

The Wild N III level has a magnification of 42 and the sensitivity of the tubular level is approx. 10" for 2mm. run. The instrument is fitted with a parallel plate micrometer which allows a parallel displacement of the line of sight. The tilting screw is graduated and these divisions may be used for levelling when the spirit level is not centred as e.g. in river crossings.

The staves have circular levels attached, are set up on heavy baseplates and are held vertical and steady by means of two rods. They are calibrated by National Standards Laboratories and their lengths need to be verified periodically. From this calibration a standard temperature for each staff is computed and a staff temperature correction applied for differences in elevation.

Levelling distances in the Metropolitan area were kept to 100 ft. between instrument and staff and equal back- and foresights were obtained by marking beforehand. (Overseas publications on length of sights in precise levelling claim 25m. as the optimum distance.) To achieve good results the levelling was started shortly after sunrise and carried on for several hours till shimmering or the volume of traffic affected the readings. It was continued in the late afternoon, if traffic permitted, till about sunset. Very light wind and moist air create good levelling conditions. Strong wind, heavy shimmer and rain stop the work.

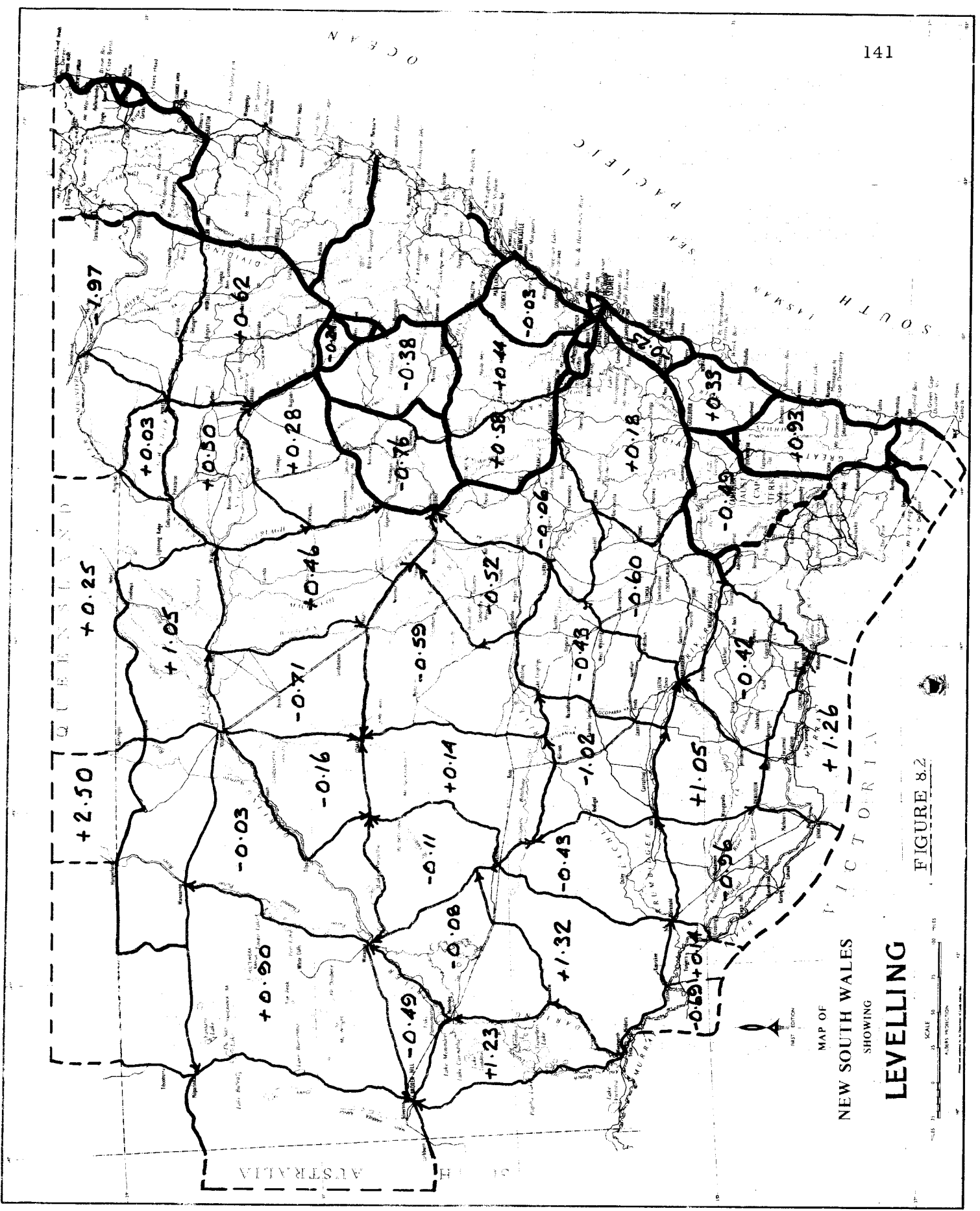

FIGURE 8.2

MAP OF
 NEW SOUTH WALES
 SHOWING
 LEVELLING



SCALE 1:500,000
 0 10 20 30 40 50
 KILOMETRES

FIRST EDITION

The results of the Sydney Metropolitan Levelling prove that levelling under the most adverse conditions (traffic, heat, wind) can give good results if carried out with proper equipment and by adherence to a proper procedure. (Figure 8.1)

Country Levelling. This levelling was a fairly slow process and when the levelling was extended beyond the Metropolitan area the allowable maximum distance was increased to 150 feet for a short period. This was not very successful and the distance is now limited to 132 ft. (2 chains). The distances are not measured any more but paced as accurately as possible. The observer has to keep a check that the sum of all backsights is equal to the sum of all foresights. In the years from 1954 onwards the precise levelling net was extended further as shown on the map, Figure 8.2.

Self-aligning levelling instruments were introduced in the Central Mapping Authority in 1960 and a wide selection of instruments is available. They have accelerated the progress of levelling.

Differences in elevation in the Metropolitan area were levelled in cm. and provisional heights were given in feet. In the meantime one-piece invar staves 10 ft. long carrying separate graduations of $\frac{1}{50}$ ft. became available and are now exclusively used by the Central Mapping Authority. Thus differences in elevation are now computed in feet from the field notes.

Computing. The computation of heights is carried out by the Computing Division of the Central Mapping Authority. The normal orthometric correction based on mean height, latitude and difference of latitude is applied before provisional heights are computed.

The literature on accidental and systematic errors in precise levelling is abundant and from it it is very clear that a strict and proper routine is essential to uniform accuracy.

4. Third-order Levelling

In view of the time factor for the completion of the levelling, the limited finance and the shortage of trained staff it became apparent that the Central Mapping Authority would not be able to provide the coverage required with a precise levelling network.

In June 1961 the Director of National Mapping wrote to the Surveyors-General of each State stating that the Commonwealth Government was very anxious to speed up the search for oil in Australia. One suggestion was that there should be a considerable increase in levelling in order to assist gravity surveys. The required standard of the levelling should be of third-order, the levelling should be run in both directions and good permanent marks should be established at regular intervals. The results would be invaluable for subsequent mapping control.

After an exchange of correspondence between the different authorities concerned agreement was reached and specifications for marking and for third-order levelling were laid down. This Third-order Levelling with Commonwealth financial assistance is carried out by Surveyors under contract to the Division of National Mapping with supervision by the Surveyor-General of the State concerned.

The preparation and supervision of this levelling is divided between Trigonometrical Survey Division and Survey Co-ordination Branch. Survey Co-ordination Branch establishes the benchmarks, which are permanent, State Survey and in black soil areas, Pipe benchmarks. It was agreed that in the western part of this State the marks should be 2 miles apart, whereas in the eastern area they would be one mile apart only. The branch also provides sketchplans of all marks.

Trigonometrical Survey Division issues instructions to contracting surveyors, receives the completed field notes and abstracts. These are verified by the Computing Division and provisional heights are computed. The Trigonometrical Survey Division keeps a progress record and recommends payments. The Division also checks the levelling in the field. Up to 10% of the levelling is checked in the field. This is also the opportunity to connect Trigonometrical Stations, Railway Stations and other foreign benchmarks along the run. Adjoining contractors are asked to overlap their levelling.

The contractor may use his own levelling instrument which should preferably be of the automatic type, but he has to use staves which are supplied by the Division of National Mapping. A calibration of these staves (folding type, not telescopic) is done periodically by means of a test bar by the Trigonometrical Survey Division.

The following important conditions are imposed upon the contracting surveyor for this type of levelling: Two runs in opposite directions must agree within $0.05 \text{ ft.} \sqrt{\text{miles}}$, the length of sight shall not exceed 200 feet (National Mapping has a limit of 300 feet), all sight lines shall clear the intervening ground between level and staff by 0.5 ft. or greater.

Since 1962 when the first contracts were let 63 contracts with an average length of 110 miles have been completed.

5. Connections to other levellings

For a uniform network of heights for the whole of the continent it was necessary to make levelling connections to adjoining States.

To Victoria they were made at Mildura, Robinvale, Piangil, Moama, Albury, near Delegete, on Cann River Highway and on Princes Highway south of Eden.

To South Australia at Hawker Gate and at Cockburn; a further connection is contemplated.

To Queensland at Wompah Gate, Hungerford, Hebel, Mungindi, Wallangarra and Tweed Heads.

Only the last two places are connections by precise levelling, all the others are third-order levelling.

Already in 1897 it was recommended that more tide gauges be established. The established ones at Eden, Moruya, Port Kembla, Sydney (Fort Denison and Camp Cove), Newcastle, Ballina and Tweed Heads have been connected by precise levelling. The gauges at Coff's Harbour and Iluka will be connected in the very near future.

6. State-wide coverage

By Precise and Third-order Levelling the whole of the State has now been covered except for an area along the North Coast where precise levelling is still in progress. So far 2700 miles precise and 6700 miles third-order levelling have been completed.

Two separate adjustments for Precise Levelling and Third-order Levelling have been computed since the Metropolitan Net was adjusted several years ago. Heights on uniform datum are now available for some 10,000 Benchmarks.

The next step, to provide a uniform network of heights for the whole of the continent will be the work of National Mapping. To my knowledge this is scheduled for 1970.

DISCUSSION ON PAPERS NO. 7 AND 8.

Chairman: Major W. Child, Royal Australian Survey Corps.

J.E. MITCHELL: LEPPERT'S definitions of orders of levelling and the tolerances appear to be incorrect. I agree with the values adopted in N.S.W. The misclosures tolerated in Victoria are:-

Definition	Tolerated Misclosures	
	British Units	Metric Units
Special High Precision Levelling	.008 \sqrt{M}	2mm \sqrt{K}
First Order Precision Levelling	.017 \sqrt{M}	4mm \sqrt{K}
Precision Levelling	.025 \sqrt{M}	6mm \sqrt{K}
Second Order	.035 \sqrt{M}	8mm \sqrt{K}
Third Order	.05 \sqrt{M}	12mm \sqrt{K}

K. LEPPERT: I do not agree with MITCHELL. We should not be misled by the difference between the probable error, estimates of which are obtained from various formulae, and the misclosure tolerance.

J.G. FREISLICH: In an error formula, $0.017 \sqrt{M}$ for example, how is M defined? What value is adopted in a loop?

LEPPERT: M is the distance: the length in an open line of levelling, or the circumference in a loop. In every case, whether a loop is closed or not, the levelling will be carried out in both directions along each section.

FREISLICH: What is meant by staff random error?

LEPPERT: The staff is calibrated against an accurate standard. Because tests including every graduation would be too tedious, 20-30 graduations chosen at random are tested, and the test yields a length for a "mean staff foot" and a standard deviation which is the random error of the staff graduation.

P.B. JONES: I would like to challenge LEPPERT'S rejection criteria. The question is whether M is the mileage of a single or a double run. Root M (\sqrt{M}) should be the total length of the line. The formula $0.05 \sqrt{M}$ cannot be applied to both the difference between forward and backward run and for loop misclosures. We can compute consistent values provided we assume that all errors are accidental.¹

Tolerances should be in terms of "mean error" and should include a statistical test, say at a 5% level.

One should analyse all loop runs by comparing the sum of the variances per loop traverse with the loop misclosures.

The national adjustment should include a careful assessment of accuracy and internal consistency. This could be assisted by adjustment of the net, not as a whole, but in sections as was done for the European net.

MITCHELL: Could the speakers comment on the presence of hysteresis in the level compensator.

JONES: Hysteresis is a function of the supporting wires and especially of the method of clamping of these wires. It does not depend on where the compensator is mounted relative to the vertical axis of rotation of the level. Hysteresis is not usually a constant amount, even for a particular level. It does not depend so much on the direction in which

¹ International Formulae are given for example in Jordan - Eggert - Kneissl. Handb. d. Vermessungskunde, X ed., Vol III, 1956, para 37, pp. 223 - 256). The distance M is the single distance either along a double run or along a loop but it is understood that each route, straight or circular must be levelled at least twice, in opposite directions. - Ed.

the compensator moves towards its equilibrium position, as on the stop against which the compensator last rested. Rapid rotation of the level about its vertical axis will tend to reduce the hysteresis effect, but may increase the accidental error. Here it is only appropriate to say that the procedures which should be adopted for precise levelling would be quite different from those suitable for third order work.

The effect of oblique horizon should perhaps be corrected in precise levelling, by releveling for each sight (using one footscrew only). This is especially the case if one is using an automatic level such as the Salmoiraghi 5190 where the tilt of the instrument can be determined from the relative positions of fixed and movable cross wires.

P.V. ANGUS-LEPPAN: Australia is somewhat unusual in accepting a third order levelling as adequate. Why is this? Who are the users of level elevations, and what accuracies do they require?

LEPPERT: The main users are Mapmakers, Geophysicists, Meteorologists and local authorities for their roads and engineering projects.

L.H. ANDERSON: The position is not as it appears because third order levelling specifications are better than usual third order. They are really of second order quality here.

ANGUS-LEPPAN: Is any consideration being given to continuing the tide gauge observations over a longer period (say 19 years).

LEPPERT: No.

J.S. ALLMAN: The details of the adjustment of the network of selected loops to take place in 1970 probably have not been decided at this stage.

However perhaps LEPPERT could indicate whether the adjustment will use either the condition or the parametric (indirect) method.

LEPPERT: The method of adjustment is before the Technical Sub-committee of the National Mapping Council and will be decided soon. It will probably decide on differing methods for different sections of the work.

ALLMAN: Could LEPPERT indicate how the observations will be weighted?

LEPPERT: The varying standards of accuracy of the different sections will be combined to compute weights.

KONECNY: Have any investigations with motorised levelling been made in Australia?

SEIDEL: No. The third order levelling appears to progress sufficiently rapidly. There have been no finances for experimentation.

W. CHILD: There are two Johnson elevation meters in Australia which have been fairly extensively used by the Army and National Mapping for provision of mapping control.

B.F. BRENNAN: Does the Department of National Mapping use various types and makes of automatic levels and if so, have the results shown that any particular type and make of level is less subject than others to systematic errors such as compensator hysteresis, oblique horizon etc. ?

LEPPERT: Between 30-40 levels have been tested. But one cannot condemn or recommend a certain make by testing a few instruments. Long field experience must be gained first. With practically all the levels tested it is possible to achieve $0.035 \sqrt{M}$ in our National Mapping work with wooden staves and without parallel plate micrometers.

MITCHELL: Third order nets controlled by National Mapping comprise 300 mile loops. Our Victorian net is much denser, being made up of 100 mile loops. All will soon be or are being adjusted. We have tried adjustment by the successive approximation method using parametric and condition equations but they gave different results.

ALLMAN: Least squares solutions by parametric or condition equations must give the same answers. Approximate least squares methods should give substantially the same results.

BRENNAN: Has SEIDEL any comments on the behaviour of different automatic level instruments in view of the Central Mapping Authority's experience?

SEIDEL: We use the Wild N3 for precise levelling and have tried the Koni 007 with success.

ANGUS-LEPPAN: Is refraction considered as an important source of error in third order levelling?

SEIDEL: No. Private practitioners do the work. They cannot be expected to take that phenomenon into account. There is a specification of one foot for the minimum staff reading.

ALLMAN: In N.S.W., in adjusting level nets what methods are used and what weights are applied?

B. PURINS: We use various methods depending on circumstances. We favour an iteration method and have a computer programme to carry it out. Usually we do not apply weights.

S. BERVOETS: Are metric units and feet both used for levelling in N.S.W.?

SEIDEL: All the work has been in feet, except for the high precision levelling covering the Sydney area. Here, because of the instruments available at the time, the work has been in metres.

CONTROL SURVEYS FOR 1:100,000 MAPPING

by

J.D. Lines.

1. Background

The compilation of the R502 map series was completed for the entire area of Australia at the end of 1966. This series, comprising 541 map sheets, will be published at a scale of 1:250,000 and includes a small percentage of maps contoured at 250 feet intervals, the balance being planimetric maps with relief shown by hill-shading techniques.

The Commonwealth Government is now actively embarking on a programme of re-mapping continental Australia over a period of 10 years at a scale of 1:100,000. This encompasses some 3200 map sheets of which about 45⁰/o will be published as fully contoured 1:100,000 maps in accordance with a new publishing specification now being prepared, and the remainder published as 1:250,000 topographic maps.

Re-photography of Australia is being undertaken with Wild RC9 super-wide angle photography at a rate commensurate with the new programme, on the premise that all 1:100,000 mapping will be undertaken only with this photography.

The Geodetic Survey of Australia will provide the basis for horizontal control extension for mapping purposes and the national programme of third order levelling will provide the basis for vertical control. The geodetic survey is completed and the levelling survey has the year 1970 as the target for completion and a national adjustment.

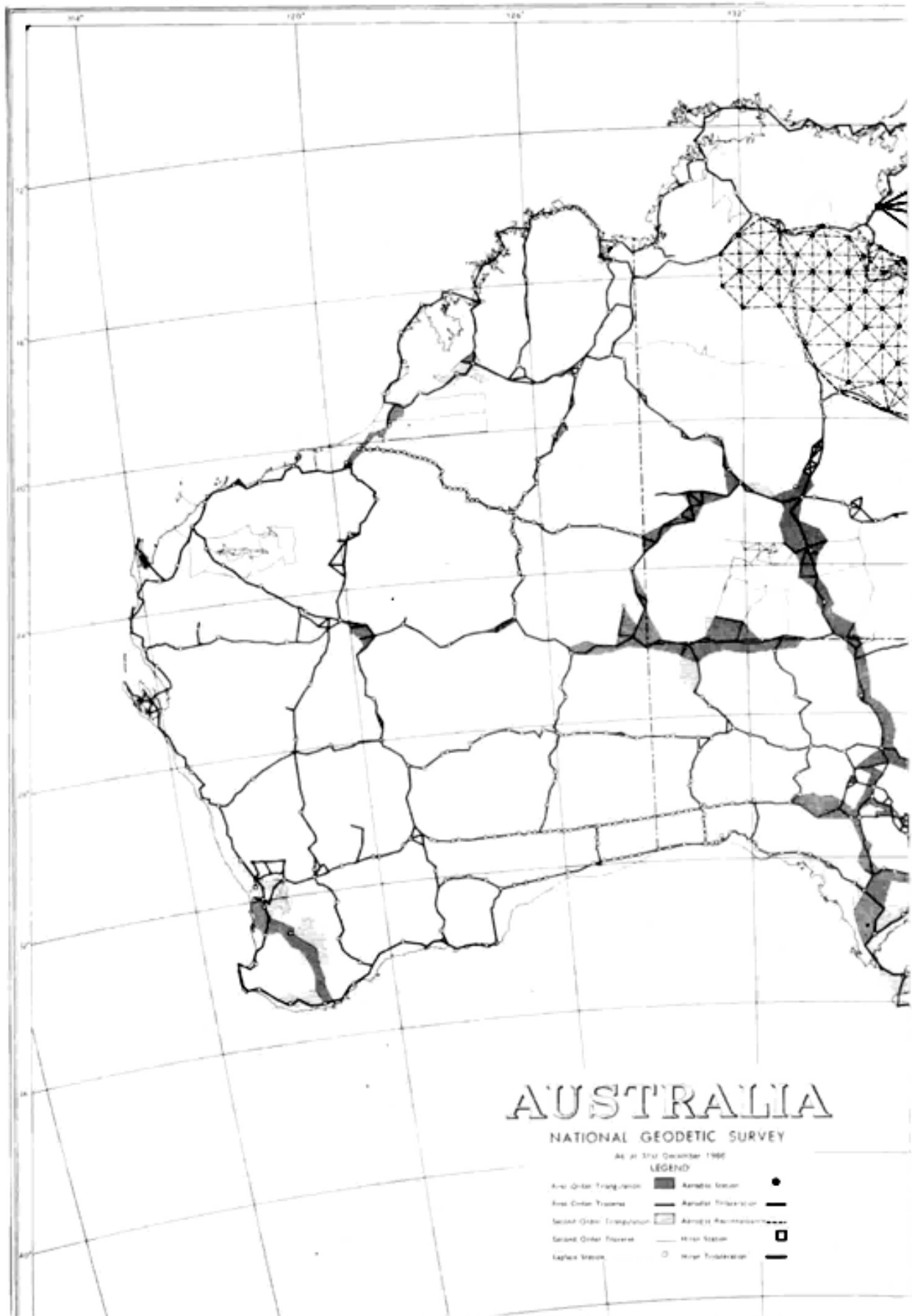

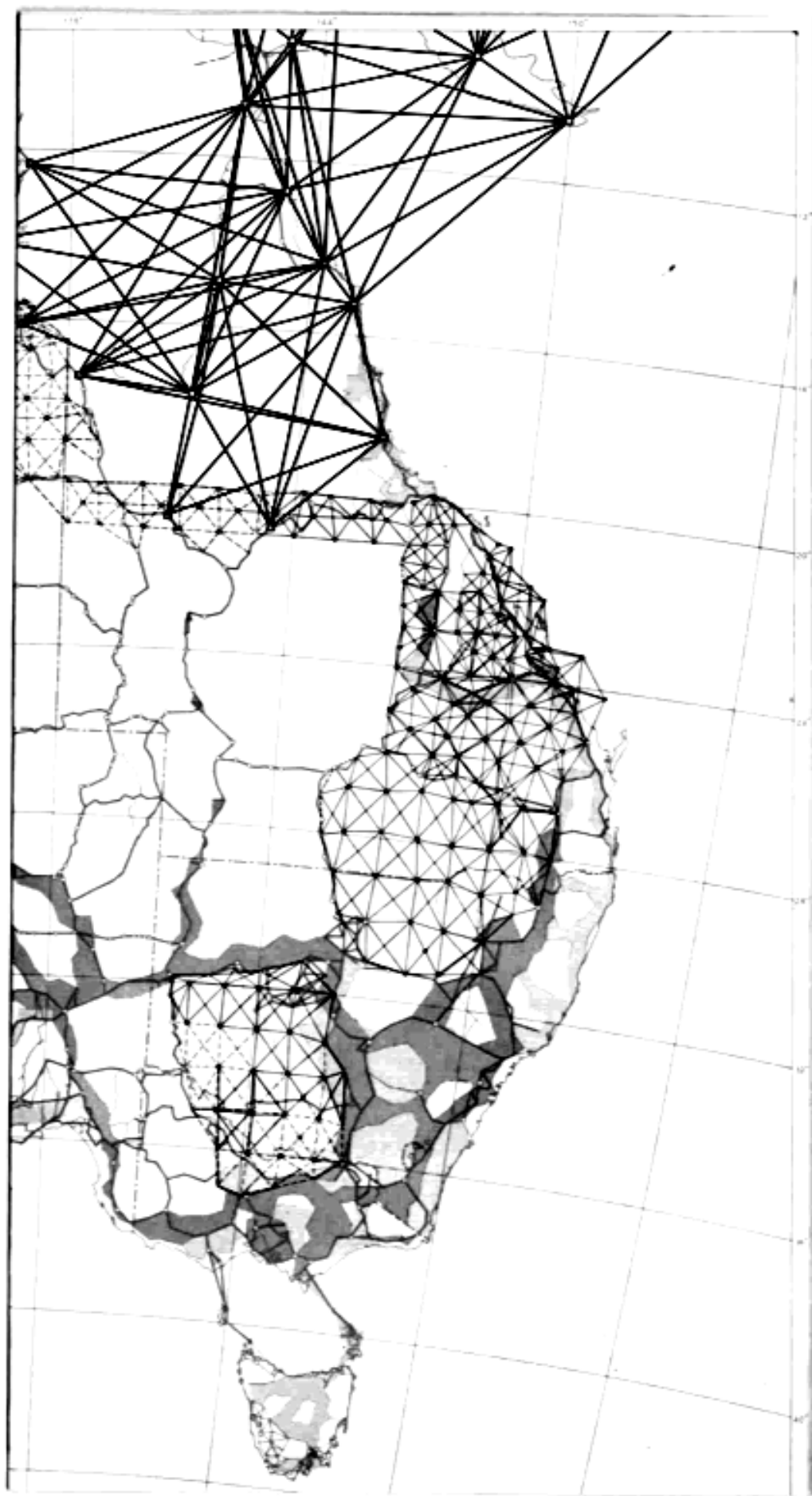

2. Introduction

Australians for many years have become familiar with medium scale maps at 1:253,440 (four miles on the ground to one inch on the map) or 1:250,000 (practically the same), on the one hand, and the larger scale maps of 1:63,360 (one inch to 1 mile), 1:50,000 and far more commonly, 1:31,680, on the other hand. This latter scale has, until quite recently, been widely used by the various States for basic topographic mapping, although it has never achieved any Commonwealth acceptance. Mapping at this scale has virtually been confined to methods embracing wide-angle photography, high quality and sometimes quite extensive ground control surveys, and photogrammetric block adjustments using observational data from either analogue or analytic equipment.

Between the two common post-war map scales of 1:250,000 and 1:31,680 there is an area where a re-thinking of methods could well yield quite valuable dividends in savings of money and time, combined with making the best use of the limited skilled manpower available in this country.

The control surveys made specially for 1:250,000 scale mapping were largely astronomical "fixes", where observations were confined to one night only with one second theodolites, and time determinations that included the personal error of the observer. Although these fixes additionally contain varying and unknown components of the deflection of the vertical in each case, they offered, in general, an acceptable solution to the planimetric control because they were:-

- (1) fairly consistent in observational error, ± 3 seconds of arc,
- (2) a unique determination of position not dependent on any other computations or adjustments of previous survey work,
- (3) generally identified on air photos, on the ground,
- (4) geographically placed specifically for mapping purposes.

As the Geodetic Survey of Australia progressed and it became possible to compare positions of points based on astronomical fixes with their corresponding geodetic values based on both the old Sydney

origin and Clarke 1858 spheroid and the new Australian Geodetic Datum (1), it confirmed the premise that the astronomical control provided a better overall result for geographical position for 1:250,000 mapping than the existing nets of triangulation of various orders of accuracy.

Also, as the older triangulation results were progressively shown to have shortcomings of one sort or another by the geodetic surveys conducted with modern equipment, and calculated and adjusted with very powerful electronic computers, there emerged a period in recent years when surveyors made new closed circuit surveys around the perimeter of areas which were to be mapped at larger scales, e.g. 1:31,680. These surveys were often made on the basis that, provided a single map sheet or a small group of map sheets were rigorously controlled for scale, azimuth and height, the fitting of the topography to a national framework would be a residual job for some other time in the future. Under this system, of course, there could be a large number of self-contained surveys based on different origins, the origin being usually one or two major triangulation stations, not at that time incorporated into the Australian Geodetic Datum.

This sort of thing is a natural corollary to any mapping programme which is not soundly based on a national homogeneous geodetic framework, properly classified in order, properly marked on the ground and properly recorded and readily available through a data retrieval system. Or a corollary to having no truly national system at all! We are not in this position any more.

Apart from the saving grace that we are, in Australia, now commencing a transition from yards and feet to metres in our topographic mapping presentation, the amount of duplication of effort necessary to convert maps based on other than a national datum, to the national datum, is a luxury which developing countries cannot afford. With modern equipment and techniques supported by forms of transportation unknown, or unavailable, to surveyors of even 20 years ago, there are now fewer and fewer reasons and excuses why mapping programmes and surveys should not be connected to the national framework of survey control.

In Australia, there is reason to take some comfort from the despatch with which the geodetic survey of the continent has been completed and results made available. Reference to the amount of work achieved in the last 15 years with the moderate resources used, is evidence of what can be done.

One important lesson which did come out of the National Geodetic Survey is that first order traversing and triangulation and geodetic astronomy have shed a lot of their occult reputation, and demonstrated to the profession at large that it is possible, in these days, to set a reasonable specification for accuracy and actually maintain and often improve on the accepted standards, while keeping up a high productive rate. That this has been done is a tribute to the skill and persistence of all who were associated with the Survey and brings out the point that there is no point in performing low order work with the equipment and techniques currently available, when it is just as easy from an observational point of view, to produce higher order work.

Very frequently, when it is claimed that third order work takes only, say, half the time necessary for similar work to second order standard, the claim is probably traceable in large measure to the differing quality of station marking. Permanence and easy location of stations are of vital importance. The quality of station marking is a vexed subject, particularly when considerations of size and composition of the mark are weighed against future vandalism and ignorance, cost, available materials and other factors. Nevertheless, as nearly all surveying authorities find it difficult to initiate and sustain a station mark maintenance programme, it is in the community interest that careful consideration be given to this most important aspect of our work.

It can be argued that a survey station of any order, badly marked, has an initial and future potential cost out of all proportion to its community value, and reflects little credit on its originator. To those who are in difficulties in controlling the quality of marking, there is good insurance value in a 35 mm photograph or photographs of all works undertaken in establishing a survey station. Other fringe benefits accrue also from these photographs.

3. Horizontal Control for 1:100,000 Mapping

Two methods of survey have been initiated for control in areas where the Division of National Mapping has the responsibility of directly producing 1:100,000 maps. These are:

- (1) Second order ground traverses using electronic distance measuring equipment.
- (2) Trilateration using airborne electronic distance measuring equipment, (Aerodist).

As a general rule, traversing has, and will be confined to areas where the topography, ease of movement and scarcity of timber and scrub allows this type of survey to achieve a rate and cost of production of map control points comparable with or better than that achieved by airborne methods. There are quite firm indications that this is the case in favourable terrain. Aerodist has quite definite cost advantages in timbered terrain and areas where access and movement by ground vehicles is difficult or impracticable.

However, as it is extremely difficult to equate the methods over the varying types of terrain that each method might encounter in the course of a field season, it is equally difficult to distinguish where one method can be accepted as being superior to the other.

4. Ground Traversing

Ground traversing in the normal situation leaves a much greater density of marked ground stations in its wake, which in the long term, is of greater benefit to the community. Against this background, the time scale of the 10 year programme intrudes, and all methods must ultimately be judged according to the capacity to provide the requisite ground control in a period not exceeding 8 years.

In some areas of Australia, ground traversing can again be advantageous in supplementing existing triangulations, where these do not provide sufficient coverage, or alternatively are not strategically placed for controlling a block of map sheets. In these areas, the introduction of Aerodist is not economically or practically sound.

It should be interposed here, that starting one year ago, the great bulk of Australia will be re-photographed on a standard flight plan. This plan can operate in all areas where the range in elevation of the terrain is less than 2000 feet approximately. Beyond this range, special flight planning is necessary.

One of the many virtues of this, is that control surveys may precede photography, although this should be avoided as far as possible. It ensures that control points are placed in the common side laps of mapping photography, and as far as possible adjacent to sheet corners. This may be considered an unnecessary nicety, but it leads to orderly compilation procedures, particularly in the region of projection zone boundaries.

Ground traversing so far has been run along parallels of latitude at 30 minute spacing, all work closing on portions of the geodetic survey. This system provides ground control at each corner of a 1:100,000 map sheet and provides additional points along the north and south edges. As an example of what can be achieved, one party of 13 traversed, to strict second order standards, approximately 1100 miles in the desert area near the coast in Western Australia in the 1966 field season.

All ground stations are additionally marked by some device on the ground that lends itself to an unambiguous identification of the point on "spot photography". Spot photography is a well established technique in the Division, and for 1:100,000 mapping purposes, it is intended that no control point shall be used for photogrammetry unless it has been successfully transferred to the mapping photography from spot photography. The zoom stereoscope has been found to be very effective for this transfer procedure.

It should be noted that pre-marking of ground control stations for the RC9 aerial photography contracts is not considered to be practicable. The very large areas to be photographed each year would demand a maintenance and inspection programme of the markers that would be prohibitively expensive both in cost and manpower.

5. Aerodist

This technique has been extensively described in Australian and Canadian literature, as set out references, (2), (3), (4), (5), (6).

A considerable amount of observational data has been obtained in readiness for the 1:100,000 mapping programme, and this is now being finally adjusted by use of the variation of co-ordinates programme on the CDC 3600 computer.

The reduction of Aerodist charts and preparation of data for the computer adjustment has been entirely a manual operation so far and with limited resources to undertake all this work, together with the inevitable problems requiring investigation that come to the surface during three years experience, it is only now that we are rapidly approaching the day when published co-ordinates will be available. Some degree of automation will soon be introduced in the form of 2 punched tape digitizers with input from a chart reader, where the operator follows the primary trace with cursors and adds other information from the secondary codes to the tape through an electric typewriter keyboard. This equipment, as with many new items of equipment, has been troublesome in initial performance, but when in full-time operation, should speed up chart reduction and subsequent publication of results quite considerably.

As with the national geodetic adjustment, no interim co-ordinates will be published, as these only add confusion to an already exacting task in recording and disseminating survey information in a country the size of Australia.

The Aerodist system is now a working tool which can be relied on to undertake a forecast programme of work in a field season. The field party is now supported by a caravan which doubles as a mobile workshop and field office. It is equipped with a portable power supply and a range of test equipment and spare parts sufficient to enable maintenance to be carried out in the field as required. This includes provision for frequency measurement, so that a continual check can be kept on drifting A+ and A- corrections, and index error. It has been shown over a period that index error is a factor to be checked and allowed for in reduction of measurements.

Average progress in a normal configuration i.e. a double-braced quadrilateral, is 2.5 quadrilaterals per week. This figure is based on terrain types which allow the remote stations to be occupied by ground vehicle. In this type of terrain, it is the practice, as far as possible, to have the stations established along roads and other places where ease of access and re-occupation are ruling factors.

Where the programme moves into inaccessible country, the reconnaissance, station marking and site preparation are effected using a helicopter. This practice leaves a clear-cut operation for the following measuring party operating with a twin-engined, fixed

wing aircraft, and a helicopter for the positioning of the remote stations. With this type of organization the measuring progress will keep pace with that expected in open country, and - an important point - will keep aircraft and skilled operator utilization up to a high level. Because of the considerable investment in the training of skilled operators and the high capital cost of equipment, the additional transport costs are justified, as they enable equipment and personnel to be fully utilized and help to keep within the time-limit for provision of ground control.

In the measurement configurations used to date there have been three basic designs.

- (1) 30 minutes of arc x 30 minutes of arc quadrilateral, double braced.
- (2) 1 degree of arc x 1 degree of arc quadrilateral, double braced.
- (3) 1 degree x 1 degree with a marked and occupied point in the centre.

(a) Doubly braced quadrilateral, 30 x 30 minutes of arc.

This has been used in an area in Queensland, where the State has also a future requirement for 1:50,000 and 1:25,000 mapping. Overlaid on this pattern is what amounts to a separate pattern obtained by measuring directly, the braced 1 degree x 1 degree quadrilaterals (see diagram).

(b) Doubly braced quadrilateral, 1° x 1°.

This was the initial approach to the density of control required for 1:100,000 scale mapping, and was based on indications arising from photogrammetric test work in the Division. Being the first field operation attempted, was also a test for the field performance of the equipment. At this stage, the horizon camera had not been introduced.

(c) Centre point figure, 1° x 1°.

With the decision setting out the priorities and scales for mapping of different areas of the continent, a further modification of the design was introduced whereby a centre point was included in each

1 degree square. These points were supplemented with a further point to be fixed along the mid-side of each 1 degree square by an airborne tri-lateration technique. This, in effect, provides control at 30 minute intervals in latitude and longitude, or at the corners of each 1:100,000 map sheet.

6. Tri-lateration

The tri-lateration technique used embraced the simultaneous exposure of a 70 mm camera in the near vertical and a Wild HC-1 horizon camera in a combined mount with the instant of exposure recorded on the Aerodist chart recorder during 3-channel operation. The mount is manually levelled. Theoretically, with the space co-ordinates of the aircraft at the instant of exposure available, and the ability to fix the nadir of the near vertical simultaneous photograph from the horizon camera exposures, this is the answer. However, this has not occurred in practice, primarily due to the fact that it is not possible in Australia to use spectroscopic film, as recommended by the makers of the horizon camera. The films used and the hazy horizons combine to give results which are not consistently acceptable.

There are other approaches to this problem and these are being investigated. One method under consideration involves the installation of a normal or wide angle air survey camera and subsequently orienting the photographs in a stereo-plotter to fit approximate control derived from the RC9 photographs, controlled approximately for scale by the available 1:250,000 compilations, and for elevation, by the "raw" airborne profile data.

7. Control Density

This matter is still under investigation and will not be decided until actual production tests of a large group of 1:100,000 map sheets have been completed. In the area in Queensland covered by the 30 minute figures, there is an opportunity to extend the horizontal control photogrammetrically by use of differing densities of ground control provided by Aerodist methods. There is some second order ground traverse control available to provide a check on residuals arising from differing combinations of density. This test, under production conditions, will provide an excellent guide to the density of control

required where only 1:100,000 maps are intended, and will show how far provision of control for future larger scale mapping is economically justified.

These decisions will undoubtedly be influenced by the photogrammetric methods to be adopted, and here is a vital decision which must take account of many factors. Any decision must always be taken in the light of our collective national ability to complete the mapping of Australia in ten years. Any other benefits that can be achieved through added refinements or greater accuracy, without significant cost increases or depletion of resources and which still allow the dead-line to be met should be considered.

8. Range of Measurement

Using the line crossing technique, occasional lines of 200 - 250 kms. length have been measured with standard equipment but the optimum distances have proved to be 100 - 150 km, while quite satisfactory measurements can be made over lines of 40 - 50 km. length (1)

Recent tests have been carried out with a master station mounted in a helicopter and so connected that the signals could be switched via a standard flat antenna or via an antenna taken from a remote set of equipment. The results indicated that a ground to air distance of 160 km. could be comfortably measured through the remote antenna under conditions in which the normal antenna gave no result at all.

The possibility of regularly using the curved antenna in a fixed-wing aircraft is under investigation. The added range capacity could greatly affect the operational economics, if tests show that larger quadrilaterals than those already mentioned can be used.

9. Accuracy Attainable by Aerodist Survey

The determination of station elevations has a bearing on the attainable accuracy. The general practice in Australia is to carry third order levelling into each Aerodist ground station and use near vertical Aerodist measurements to calibrate aircraft altimeters.

Early assessments of Aerodist measurements led to the assumption that a standard error of ± 3.5 metres was practicable from a single line crossing for lines of 100 - 150 km. length and Canadian results seem better still. However, local operation over a three year period indicates that about ± 4 metres would be a more appropriate figure.

Investigations carried out indicate that quite large blocks of Aerodist trilateration adjusted to perimeter control (assumed free of error) will result in average co-ordinate position errors of about one-half the standard error of a line measurement and indicate that the average correction to individual measurements is also about half of the standard error of the line measurements.

In practice, these errors and corrections will be directly affected by the residual inaccuracies of the primary network and the possible non-elimination of lines with large errors. From results available, it would seem that a co-ordinate precision can be expected of approximately ± 1 to 2 metres relative to the surrounding control.

10. Vertical Control

Airborne surveying techniques already developed, together with those under development and those that will surely come with advancing technology, are supplanting the hitherto classical surveying methods in many aspects of data acquisition for mapping purposes. These methods have come to stay, and although frequently the initial capital cost is high, the improvements in accuracy will eventually provide direct measurements of an order of accuracy that will certainly suffice for topographic mapping of many scales and make it less and less necessary to derive data.

These methods will require the provision of basic data networks as a reference, and in the field of vertical control, the third order levelling network being built up over Australia, is providing this basis.

In the 1:100,000 mapping programme, the approach of using airborne survey measurements as vertical control for individual models, is being pursued in many areas.

11. Airborne Profile Recording

The equipment in current use is the Canadian airborne profile recorder which is operated on contract to the Division. This equipment utilizes the radar principle which has a cone of radiation at the aircraft of order of 1.5 degrees. The radar profile is presented as pen traces on a paper chart and is related to the terrain by exposures of a vertical 35 mm. frame camera, which are automatically recorded as an event on the paper chart.

Apart from the inherent uncertainties in establishing which point on the ground is "heighted" by radar in rough terrain, there is also the problem of correctly establishing the gradient of the isobaric surface along which the aircraft flies in the course of recording a profile. The standard length of a profile is presently about 100 miles, and these profiles are run along the common side laps of the mapping photography.

Although a practical every-day procedure has yet to be evolved for office processing for compilation purposes, it is now evident that provided due care is exercised in equipment operation and full recording of all pertinent data in the aircraft, and opportunities are taken or made to compare the profile with known ground heights, the profiles used intelligently will provide individual heights on each model not in error by more than 25 feet. When the model is levelled to more than 3 heights, the overall result will be much improved.

This method, while not perhaps completely removing the necessity of bridging for height, should reduce bridging to a very small number of models in isolated instances. The use of profiles would have its greatest application where photogrammetric adjustments are made for planimetric position only.

12. Laser Terrain Profiler

The laser technique, for long confined to the laboratory, is now being developed, inter alia, to make use of its properties in the field of measurement. Already, a laser device has been constructed overseas to measure distances on the ground with an accuracy of 1×10^{-6} . Its potential has also been put to use in the construction of laser airborne profile recorders overseas for various purposes, including installation in a satellite.

Considerable research in the laser field has been conducted by the Weapons Research Establishment (W.R.E.), Department of Supply, and in 1966, the Department of National Development sponsored a project within the W.R.E. for the development of a laser terrain profiler for use by the Division of National Mapping. Design studies have now reached the stage where the decision has been made on the type of laser to be used, and specifications for all other components are sufficiently advanced to enable ground trials to start in September 1967, followed by airborne trials later on in the year.

The laser will be a C.W. Argon Ion type operating on a wavelength of 4880 \AA . The transmitter and receiver will be a Cassegrain optical system with a field of view of both the transmitter and receiver of 10^{-4} radius, which is of the order of 20 seconds of arc. The height computer will provide an output directly in metres and in the finally engineered recording apparatus, it is hoped that the height record will be imaged on to the same roll of film as the terrain image from strip camera.

The laser will sample a spot on the ground of one or two square feet, height measurements will be made at the rate of 50 per second, and the resolution of the laser in height measurement, will be better than 0.3 metres.

From this brief outline, it can be seen that the potential of this system is a very substantial increase in accuracy over the radar-type profile recorders, although the problem of determining the gradient of the isobaric surface used as a reference still remains. However, as the pencil beam of laser light is so small, the opportunities for calibrating on existing height control points on the ground are very much greater, and undoubtedly errors due to this source can be effectively minimized.

13. Johnson Elevation Meter

This equipment has lived up to its reputation of providing heights to \sqrt{D} in feet where D is the distance in miles run. This figure relates to one-way measurement. It can be improved to about $0.6 \sqrt{D}$ with two-way measurement.

So far, this equipment has been used mainly for making comparisons with airborne profile records (A.P.R.), and the results of these have, on occasions, considerably improved the accuracy in profile heights in the absolute sense. It has also had a useful role in providing profiles of airstrips tied to the levelling network for use as datum surfaces for APR operations, and this it can achieve in a very expeditious manner.

In the flat country, where the road system is reasonably extensive, it has demonstrated that a network of heights can be obtained which are adequate for contouring for 1:100,000 purposes. Again, in this operation, all work is connected to the third order level network.

In Victoria, elevation meter heights have been obtained to supplement existing vertical control for use in photogrammetric block adjustment of a very large area of eastern Victoria being undertaken by the Victorian Department of Lands and Survey for a portion of the 1:100,000 mapping programme.

From the equipment and methods outlined, will come the vertical control used on the 1:100,000 programme by the Division of National Mapping. These methods may be supplemented on occasions, by forms of barometric heighting using helicopters for transport, and in some instances, height control may be derived photogrammetrically, but as far as possible, the accent will be placed on the use of direct field measurements.

14. The Future

There are many interesting speculations concerning future methods to be employed in topographic mapping, and no doubt, the coming decade will see changes sweeping into mapping techniques through the effects of automation.

Progress towards automation in surveying and mapping procedures is something that the profession will have to live with, although there are widely differing views on the impact of automation. Already, automated stereoplotters, with their potential for production of orthophotographs, are on the market, and they will improve in performance and capability from year to year.

One subject worthy of consideration by all engaged in topographic mapping concerns some means of establishing the nadir of aerial photographs at the time of exposure. There are three methods of achieving this which come to mind:

- (1) Stabilizing the entire camera within its mount.
- (2) By a remote sensing apparatus, determine the dis-levellment of the camera at the instant of exposure.
- (3) So arranging the control system, that the camera only exposes when it is vertical.

Although there has been quite an amount of investigation into these problems a solution which enables the camera to operate in normal commercial-type aircraft is still required. Modern technology offers several methods of achieving this goal, but an answer must surely come from communication between scientists and those engaged in aerial surveying.

Finally, in Australia we are now fortunate to have a geodetic framework for mapping, which is modern, accurate, easily recoverable and for which information is freely available. The levelling network is now fairly extensive and in the next few years will encompass this country. Not only the governmental mapping authorities, but all those who have direction of large projects, be they surveyors, engineers or other project executives, should use their endeavours to have all large area surveys connected to the national schemes.

These connections will not only provide checks on the work being undertaken, but would make worthwhile contributions to survey co-ordination and the benefits that will flow from this work.

References

- (1) Commonwealth of Australia Gazette No. 84, 6th October, 1966.
- (2) J.D. Lines. Aerodist in Australia 1963-64. Australian Surveyor, Vol. 21, No. 2, 1966.

- (3) B.P. Lambert, et al. Aerodist Surveys - Report on operations carried out by the Australian Division of National Mapping since 1963. I.A.G. Symposium on Electromagnetic Distance Measurement, Oxford, England, 1965.

B.P. Lambert. The Use of Aerodist for filling in between Tellurometer Traverse Loops. Commonwealth Survey Officers Conference, Cambridge, England, August 1967.
- (4) L.G. Turner. Aerodist Operations in Australia. Document E/Conf. 52/L44*.
- (5) Major E.U. Anderson. Operation of Aerodist distance measuring equipment in Papua - New Guinea, Document E/Conf. 52/L53*.
- (6) Numerous reports on Aerodist operations published by Department of Energy, Mines and Resources (formerly Department of Mines and Technical Surveys), Canada.

A.C. Tuttle. Aerodist in geodetic surveying in Canada. Document E/Conf. 52/L95*.

* Presented at 5th United Nations Regional Cartographic Conference for Asia and the Far East, Canberra, Australia, March 1967.

AUSTRALIAN DEVELOPMENTS IN THE USE OF HOVERING HELICOPTERS
TO ESTABLISH SURVEY CONTROL

Major W. Child - Royal Australian Survey Corps

ABSTRACT

1. The use of helicopters for geodetic and topographical surveys is now receiving greater prominence. In the past helicopters have been employed mainly for positioning ground survey parties, and on occasions for long range barometric surveys and spot photography. The United States Geological Organization has evolved a technique for use of the helicopter as an elevated station to which distances, and horizontal and vertical angles are measured. These observations are reduced to ground level to determine the co-ordinates of ground zero immediately beneath the helicopter. The Australian concept is very similar except that to widen the parameters for operation of this system in Australia and Papua/New Guinea, the optical 'hoversight' used to maintain stability of the helicopter above ground zero, is rejected in favour of television componentry which, on preliminary investigation, is considered to provide greater hovering potential. This paper describes briefly the history, current and future developments of this system and problems to be met in perfecting the Airborne Survey Control System.

THE PROBLEM

Field survey work is often restricted and unduly time consuming when ground stations which are ideally suitable for use as mapping control, are located in areas virtually inaccessible to conventional means of transport or where access is so difficult as to make the fixation of control points uneconomical.

It is relatively easy for a helicopter to land on or adjacent to any desired control point, but by the very nature of the terrain and the distances involved the unknown ground station and the known ground stations are not always intervisible.

The situation then requires some form of tower to be erected at one or all of the stations concerned, or for some form of greatly elevated platform to be positioned above the unknown ground zero. To this end the ABC System (AIR-BORNE CONTROL) System was devised.

The United States Geological Survey decided that this could best be achieved by employing a helicopter with extremely good hovering capabilities to remain suspended above ground zero at an acceptable height for periods of time sufficient to enable theodolite observers at distant known ground stations to read vertical and horizontal angles and for a series of rapid electronic distance measurements to be determined.

THE AIR-BORNE CONTROL SYSTEM

For this purpose a Hiller 12E Helicopter was selected with a special stabilizing device to assist the pilot to hover. (1) To this helicopter was fitted a flashing beacon to make identification easier and permit accurate angular observations.

For distance measuring, the Hydrodist system manufactured by Tellurometer Inc. was installed in the aircraft and also employed on known ground station locations. The instrument gave direct readout in metres with accuracy to 20 cms.

A hoversight was specially designed for use in the Hiller 12E and consists of a dampened pendulum which has a self contained light source for projecting a beam of collimated light through a semi-transparent mirror. With the aid of another mirror the observer can view an erect image of the terrain below and the image of the light. The image of the lamp filament projected against the terrain image defines the vertical.

(1) Light helicopter stability augmentation system - Mario S. Latina Project Engineer Flight Controls - Hamilton Standard Electronics Department.

A height indicator consisting of a reel of dacron line with a weighted end completed the airborne equipment. As the line is 'played' out, it passes around a calibrated drum geared to a dial counter graduated in feet.

The known ground stations parties were each equipped with a Hydrodist remote station and a suitable theodolite.

The US Geological Survey decided after extensive tests that the Air-borne Control System (ABC) was suitable for surveys not exceeding 70,000 feet in length; that the maximum hover height is 300 feet but preferably lower. That redundant measurements are needed for checked position and elevations. Two measurements are needed for horizontal control points, and for vertical control points where a horizontal angle is less than 15 degrees. Lastly, that the known ground stations should be stronger than the results desired.

An alternative method is to delete distance measurements and establish position by triangulation on the flashing beacon. The usual requirements for an intersected point apply in this instance.

AUSTRALIA'S APPROACH TO THIS PROBLEM

Faced with the problem of fixing numerous control points in inaccessible or difficult terrain in Australia and New Guinea, and of a requirement to position this control as economically as possible for 1:250,000 and 1:100,000 map series, the use of a helicopter-borne platform as opposed to erecting towers became immediately apparent. However the limiting factors of the US Geological Survey's System precluded its use in Australia under the aforementioned conditions.

Other limiting factors had to be considered, which were not compatible with the US Geological Survey System. These were:

- a. The non-availability of a stabilized Hiller 12E Helicopter.
- b. The absence of a Hydrodist System for distance measurement.
- c. The lack of a suitable hoversight.

In an endeavor to overcome these difficulties the Royal Australian Survey Corps requested assistance from the Defence Standards Laboratory (DSL) situated in Victoria, and the Weapon Research Establishment (WRE) in South Australia.

Parameters stated for the acceptance of such a system were considerably more extensive than those attainable with the US Geological Survey equipment, and were listed as follows

1. The helicopter must be capable of being observed over a minimum distance of 20 miles and preferably up to 35 miles.
2. The helicopter must be able to adopt a measurable hover at altitudes from 10 ft to 4000 ft above ground level to a maximum altitude above MSL of 12,000 ft.
3. The helicopter should be able to hold position within a sphere of 10 feet radius of a point in space above ground zero.
4. The pilot must be capable of hovering within this given radius for approximately five minutes at a time, over a period of 20 to 25 minutes allowing not less than 4 separate rounds of observations to be taken.
5. The equipment so designed should for preference be completely airborne. If this caused undue delay or expense, a ground located equipment would be acceptable as a part solution.

Our requirements were studied by both DSL and WRE and after consultation with experts in the electronic and optical field, and talks with helicopter pilots, it was established that the parameters stated were possibly too critical to enable an equipment of reasonable cost to be produced in a short period of time.

Consequently these were scaled down to meet the conclusions reached by a feasibility study and were revised as follows:- (See fig 1.)

1. Observations to a helicopter 20 miles distance was readily acceptable, but 35 miles was considered extremely unlikely unless special lights were installed on the helicopter.
2. It was found that most pilots deprecate hovering below 500 feet when not in ground effect. The minimum hovering altitude was raised from 10 to 500 ft.
3. The ability of the helicopter to hold position within a sphere of 10 feet radius of a point in space above ground zero was reduced to 5 feet. This was considered to be an optimum target.
4. The time condition of five minutes for hovering to permit observations would normally be met under good flight conditions. This time may have to be reduced to three minutes when weather conditions deteriorate.

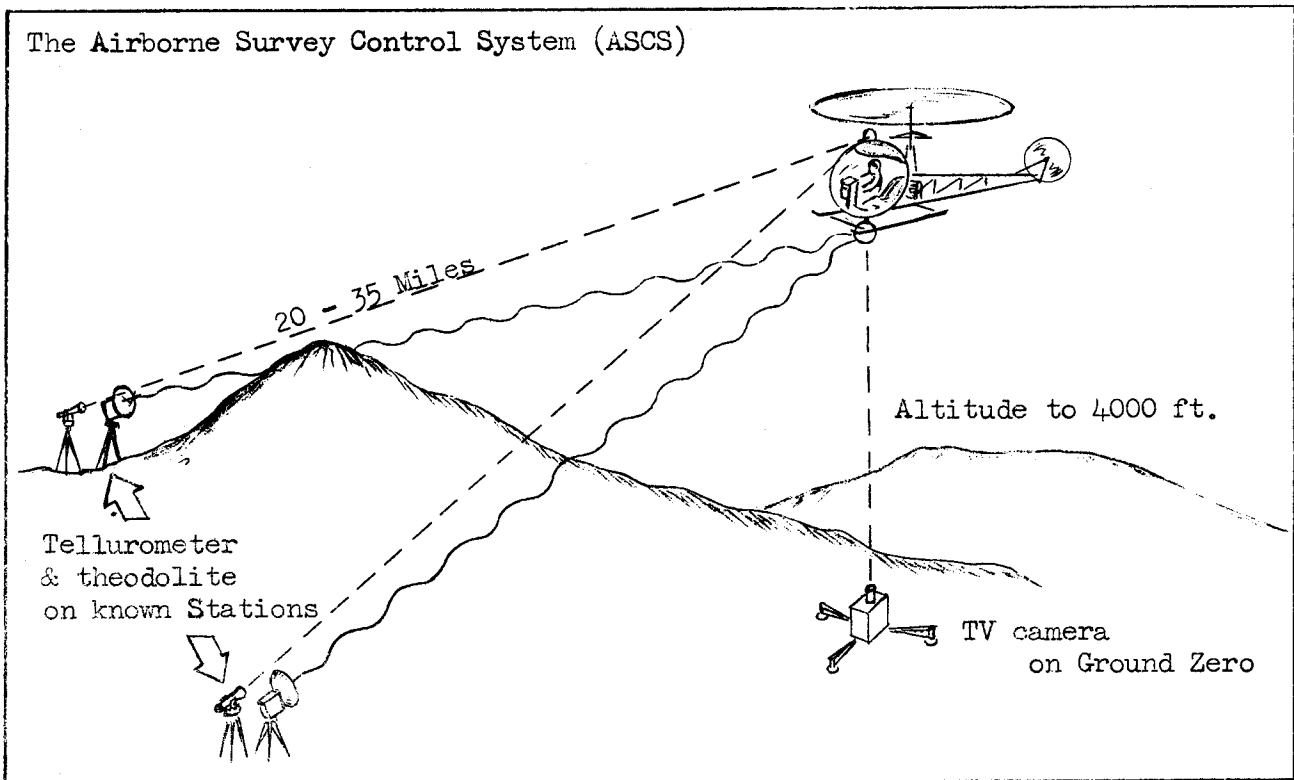

Figure 1

AUSTRALIAN DEVELOPMENT

It was agreed that the efforts of these two research organisations should be divided into two separate investigations, and so after consultation WRE undertook preliminary research into a completely airborne optical plummet device whilst DSL concentrated on a ground located equipment to assist the pilot to hover over a point.

In the space of 2-3 weeks both organisations produced mock-up models of their deliberations.

The Gyro-Stabilised Optical Plummet

WRE produced a gyro-stabilised sight with semi-reflecting mirror. Because of the lack of suitable helicopters it was necessary to fasten the sight externally to the Bell G347 B1 helicopter on the passengers side. This mirror could not be used to effect because of the position of the sight in respect to the pilot.

Mr. J. Wood of WRE despite his enthusiasm for the task ahead soon realised that the optical sight was only suitable for low altitudes because of the lag inherent in this particular gyro-stabilised system. It was possible to successfully plumb to an altitude of 1000 feet but anything beyond this height was considered impracticable. This project was finally abandoned.

The Projected Light System

The Defence Standards Laboratory commenced investigations into a projected light beam system based on a method developed for guiding ships into narrow channels.

As adapted to the present problem, it comprises a vertically directed light beam consisting of three segments of different colours. By focussing the image of the segmented boundaries at infinity, the boundaries always appear well defined to an observer at distances greater than about 150 feet from the projector. Thus in a typical arrangement; the source when viewed from a distance appears to be red, green or yellow according to the segment in which the observer happens to be. If he is close to a boundary between two segments, then small movements (of the order of 10 inches at a distance of two thousand feet) cause the colour to appear to change, and if he is at the point where the three segments meet, the source appears to be white. A mirror could be placed on the canopy of the helicopter so that the pilot may view the vertically directed light source.

As a first test of its feasibility, the system was flight tested near Amberly, Queensland on the 26th and 27th of January, 1966, using helicopters of the 16th Army Light Aircraft Squadron. A suitable mirror had not been constructed so that the beam was of necessity inclined at angles varying up to 40 degrees from the horizontal.

The slide pattern shown in Figure 2 was projected so that the red-green boundary coincided with the wind direction and the yellow segment was down-wind from the central patch. The pilot's task in hovering a helicopter is least difficult when the helicopter is heading into the wind. The pilot reported over a radio network when he considered that he was in the central white patch and theodolite readings were made, which enabled his position to be calculated.

Little difficulty was experienced in locating the aircraft within the light beam or with recognition of each of the three colours at distances of nearly 10,000 feet. However, it was hard to distinguish the central white region from the yellow beam.

The positions of the aircraft calculated from theodolite readings are not recorded in detail here, but they may be summarised as follows. Of the 15 readings obtained about 50 per cent were within the distance of about ± 20 feet from the mean line. It was thought that in the remaining 50 per cent the pilot was mistaking the yellow light for the central white patch.

These results may be compared with a spread of approximately ± 150 feet when the pilot was asked to hover (without the aid of a projector) at 3000 feet above a farm house.

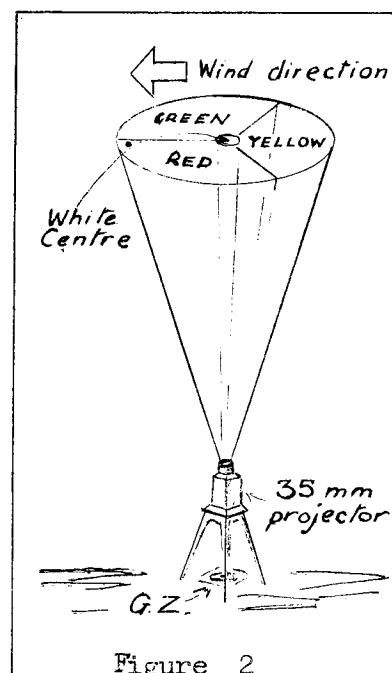

Figure 2

A second trial was held at Amberly from 22nd to 24th February, 1966, but due to a number of adverse factors such as inclement weather, poor radio communications, and rapid change over of pilots, the trials were not very fruitful.

However, some interesting results were obtained: The mirror was shown to be usable. It was very difficult to maintain both horizontal position and altitude simultaneously. In one flight when the hover point was obtained some five times the spread of positions (measured by theodolites) was over 40 feet from the mean position.

At this stage of development, therefore, the system using a projected light beam did not appear to be promising and was discarded in favour of a television system as an aid to hovering.

The Television System

In this system a television camera is placed on the ground with the camera optical axis vertical. The picture is transmitted to the aircraft and displayed on a receiver placed in front of the pilot and alongside his instrument panel. The pilot therefore sees an image of his own aircraft and can manoeuvre into the centre of the screen of the television camera. He is thus provided with information not only of his position as in the light projector method but also of rate, i.e. he knows where he is, in which direction he is flying and his velocity. A television system was considered suitable because its ground based equipment is compatible with the projected beam system which was then being constructed in the D.S.L. Engineering Workshops.

It was quickly shown that a satisfactory picture could be received in the aircraft. A major difficulty, however, was encountered early in the trial: the pilots' reluctance to view the receiver, which, of necessity, must be small (a 5-inch picture tube is used). The pilots at first declined to watch it on the grounds that there were too many other instruments to watch and that they feared losing control over the aircraft's attitude. Expressed in another way, they wished to use the horizon as an indication of their flying attitude as they have been trained to do.

On the earliest flights, therefore, an observer viewed the screen and continuously called instructions to the pilot. This method gave some success; at 1500 feet the aircraft remained almost continuously within a radius of approximately 70 feet of the centre point and made quite frequent slow passes through it.

On an average 10 per cent of the time was spent within a radius of 20 feet. This represented a great improvement over any previous result with the light projector.

Eventually a pilot was persuaded to view the screen himself, which he did without any trouble. There was an immediate improvement; in one short flight of 10 minutes at 2000 feet the aircraft remained within approximately 10 feet of the central point except for two or three very short excursions to about 50 feet. Positions calculated from theodolite observations confirmed these data, which were deduced from motion-picture film records from a ground-based monitor television receiver.

Having therefore established the feasibility of the system it was decided to carry out a series of flight tests at the School of Military Survey, in Bonegilla, Victoria. The detailed conduct of these tests is too lengthy to include in this paper. However, to provide an idea of the accuracies obtainable with this method of summary of observations is given in Table 1.

EQUIPMENT

Unlike the development of the Air-borne Control System by US Coast and Geodetic Surveys, we were faced with utilizing existing available equipment to assure ourselves that the system was feasible. We were stringently restricted in time which inevitably led to a severe restriction in the type of equipment readily available.

Obviously, the most suitable DME obtainable is of the Hydrodist type complete with omnidirectional antenna. A tracking theodolite is more suitable than the standard third-order theodolite employed, and the charted helicopter could have proved less tiring to the pilot had it been fitted with an augmented stabilizer. None of these was available and we had to proceed with the best means at our disposal. These components are listed below.

Airborne Equipment used in the Bell 47 G3 B1 Helicopter

1. 2 Television Receivers
 'Sony' 5-202V, 5 in; operating from helicopter 24V power supply, or similar. 1 for pilot, 1 for the operator surveyor.
2. Antenna for the TV receivers
 Mounted on the airframe to the rear and forward of the tail rotor.
3. Electronic Distance measuring equipment
 A MRA2 Tellurometer, positioned on the centre seat of the helicopter and powered from a 12V external wet battery on the skids.
4. 17 inch Parabolic reflector and dipole fitted to an elevated aerial which protruded through the floor of the cabin and was capable of being pointed in any direction by manual control in the cabin.
5. Altimeter to provide height information.
6. VHF radio communications provided by AN/PRC 25 dry battery operated radio fitted with duplex receiver and headgear so as to allow operation by both pilot and surveyor. This radio could also be operated from 24V wet battery in the helicopter if so desired.
7. Antenna for VHF radio. A fixed copper wire aerial secured to the air frame and the starboard skid.
8. Meteorological equipment
9. Standard Aircraft flashing warning light. A suitable beacon light has not been developed and the helicopter warning light was used for this purpose. This light proved unsuitable.

Ground Zero equipment

1. Pye 'Lynx' TV2A with vidicon pick-up tube, powered by 24V dc battery. (Figure 3)
2. Tripod for positioning the camera centrally over the point to be co-ordinated, and to allow levelling so that the optical axis of the camera is truly vertical.
3. Antenna for the TV transmitter.
4. VHF radio communications in this case AN/PRC 25 radio.
5. Altimeter to determine the altitude of the Ground Zero. Where large altitude ranges, and changes in meteorological conditions are expected a Psychrometer is required with this altimeter.

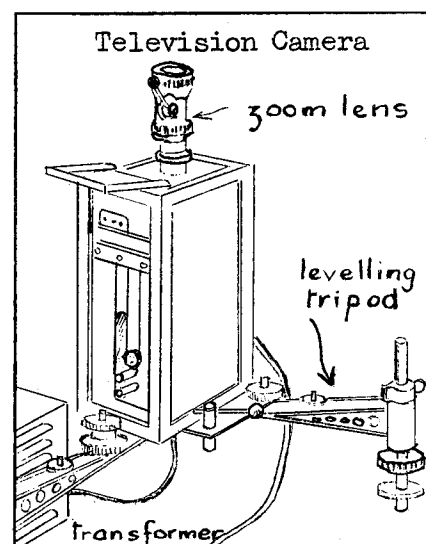

Figure 3

Television Camera Calibration Equipment

The equipment used for ensuring verticality consists of a telescope in a mounting provided with universal tilt motions and supported by three legs. (See Figure 4) The telescope is provided with a Gauss eyepiece, and a mercury bath is placed on top of the camera box. In use, the telescope is focussed on infinity and by adjustment of the tilting mount the cross-hairs of the eyepiece are made coincident with their image reflected from the oil-dampened mercury surface. The mercury bath is then removed, and for the television system, with the camera and transmitter turned on, an image of the cross hairs is visible on the receiver. The camera and its circular graticule are then positioned so that the junction of the cross hairs coincides with the centre of the graticule near the centre of the monitor screen. The bubbles of the spirit levels are then adjusted to their central positions using the spring loaded screws supplied. When the equipment is being used in the field it is expected that periodic check of this adjustment will be necessary.

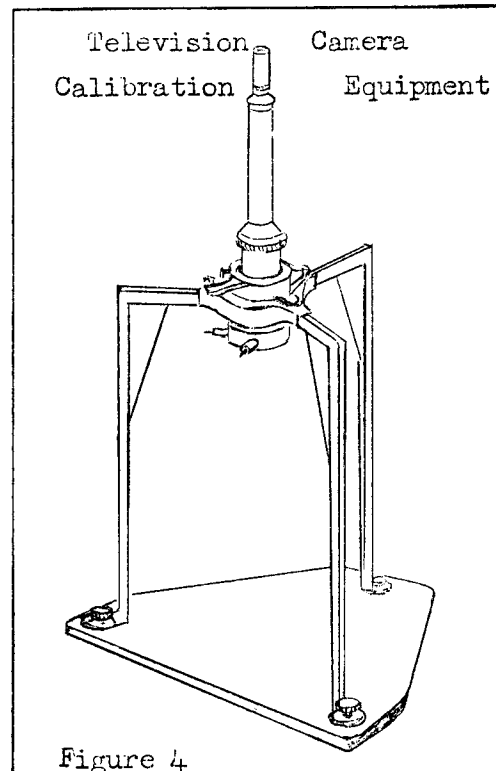

Figure 4

The precision with which the vertical can be set is estimated to be approximately 20 seconds of arc but this has still to be verified in practice. (see page 8, Accuracy factors).

Equipment located at Known Ground Stations

The survey equipment located at known ground stations comprises:-

1. Distance measuring system. Tellurometer MRA Mk 2 model. The circular 17 in reflector should always be used in the field in preference to the smaller rectangular reflector.
2. Theodolite fitted with artificial illumination and rheostat control to obviate use of the sun for internal illumination.
3. VHF radio communications with 2 handsets or microphone and head gear assembly to allow free use of hands.
4. Altimeter and meteorological equipment, for height and refractive index observation data.

OPERATIONAL PROCEDURES

Considering the difficulties to be overcome when attempting successful Tellurometer distance measurements to a hovering helicopter, and the requirement to observe simultaneous angular observations, it is evident that observations must be extremely well controlled and completed as speedily as possible. Some factors which assist in efficient operations are given below.

Location of the Airborne Party. Points which are required to be co-ordinated are pre-selected, and to assist ground observing parties in quickly locating the helicopter, approximate bearings and distances are extracted together with a table of elevations or depressions from the ground station for varying altitudes above ground zero. These need not be precise tables but should be sufficiently accurate to locate the helicopter in the theodolite telescope. The field of view of the theodolites used is 40 minutes of arc. Where distances are short and the helicopter can be sighted with the naked eye these preliminaries are not essential.

COMPUTATIONS

During the trials held at the School of Military Survey it was necessary to maintain a high rate of computing in order to assess the results of each day's observations. In the following paragraphs brief details of these computations are given.

Intersection Computation

Computation of co-ordinates of the aircraft from the intersection by ground stations was accomplished on the Twin Brunsviga Model 13Z using five figure tables of natural functions of tangents. The grid bearing to the helicopter for each intersection was obtained by adding the angle from the RO to the helicopter, to the known grid bearing from the occupied ground station to the RO. (Annex A)

Because of the nature of the trial and the requirement to assess the spread of the instantaneous observations taken on each command by the controller, each pair of single face observations were computed as separate intersections. Normally, as observing techniques improved both left and right face observations would be made.

Although computation of intersections by machine is speedy, the bulk of observations taken during each day took some time to complete even employing teams of computers. In order to obtain early indication of the accuracy of the intersections relative to the known co-ordinates of the ground zero, recourse was taken to producing a graphic al plot of the intersections after each daily set of sorties from the available angle books.

Intersections were obtained by laying off the amount in distances that the individual pointings were in error from the known bearing from the survey station to the ground zero calculated by plane trigonometry from the known co-ordinates.

For the distances involved these were treated as being parallel to the known grid bearings and plotted accordingly. The intersection of the amount of the offset from each of the bearings from the two ground stations indicated the helicopter position for that pair of observations.

Altitude of Aircraft Computation

The altitude of the aircraft at each pointing was computed using the Royal Australian Survey Corps form AAF 011 by natural methods (see Annex B). Curvature and refraction was derived from the graph shown at Annex C. Where the vertical angle was missed at one of the stations, the aircraft height is derived from a single ray observation from one station only. The altitude obtained was used to reduce the Tellurometer measured slope distance to the horizontal distance.

Determination of the Elevation of Ground Zero

The system as currently developed provides for the elevation value of the ground zero to be determined by reading an altimeter positioned in the helicopter as it lands to position the television camera over the ground zero mark. Should a complete airborne system be developed at a later date it will be necessary to devise another method for determining the elevation of the unknown ground zero. This could possibly be accomplished by introducing a scale graticule into the television viewing system which would register the image of the helicopter along the scale in direct proportion to its height above the camera lens.

ACCURACY FACTORS

Helicopter Altitude

It is difficult for a helicopter pilot to position his aircraft above ground zero five or more successive times and on each occasion at the same altitude. There could be altitude differences of greater than 50 metres. How then does this height difference affect the probable accuracy of the system?

Assuming that the slope of the measured line is not excessive the slope correction is given by $\frac{\Delta h^2}{2D}$ (neglecting 2nd term).

An error of 50 metres in a 30,000 metre distance has the following value:-

at 100 m (150m) e – 0.209 metres from true value
 at 250 m (300m) e – 0.458 metres from true value
 at 1000 m (1050m) e – 1.709 metres from true value

The error can best be expressed as

$$e = \frac{\Delta h_1^2 - \Delta h_2^2}{2D}$$

Where h_1 is correct height

h_2 is erroneous height

Incorrect Vertical Plumbing of Television Camera

Taking the worst example of departure from a truly vertical condition of the camera lens we can consider a departure of 30 arc minutes from vertical which expressed as the sine of the angle of departure – sine of 30 minutes – 0.0087265 or approximately 9 parts per thousand. This condition at an altitude of 1,000 metres produces a departure from true verticality of 8.7 metres. This is admittedly excessive but could be acceptable under certain conditions. However, the calibration equipment more or less guarantees verticality to within 30 arc seconds, and more often better. It will therefore be realised that under normal conditions errors due to lack of verticality of the television camera lens system will be so small as to be discounted.

Errors Introduced By Use of Tellurometers

Undoubtedly the greatest error introduced into the system will be caused through using the Tellurometer which is specifically designed for static line measurements. Those who are conversant with the MRA-2 model will realise that as the helicopter deviates from the truly vertical ground zero spatial position during periods of hovering, the 'gap' in the circular trace on the CRO will swing accordingly. The greater the deviation, the greater the swing. A good observer, after improving his technique will be able to visually assess the swing and 'mean' the result. From past experience an average assessment has resulted in errors approximating ± 4 milli-micro-seconds or $\pm 0.6m$ (approx). Considerable research is required before these early results can be confirmed and a systematic pattern of errors evolved.

Summation of Errors

In addition to those errors listed above there are other random errors introduced by unknown values such as meteorological conditions along the measurement path, horizontal and vertical refraction depending upon the time of day angular observations are made, and prevailing weather conditions which reduced the hovering capabilities of the helicopter. However, taking into account all of these errors there is very strong evidence to assume that the Airborne Survey Control System will provide accuracies suitable for medium scale mapping up to 1:50,000 scale.

FUTURE TRENDS

The Airborne Survey Control concept has been proven, and the prototype equipment is currently being produced. The main components of this prototype will not vary greatly from the equipment used on the trials at the School of Military Survey. The system will be dependant upon ground located television camera equipment and will therefore be limited to helicopter accessible country.

Concurrently with this equipment project, there is a feasibility study proceeding to determine the probable cost of a wholly airborne survey control system where the television camera, transmitter, and receiver are in closed circuit within the helicopter.

A system of maintaining camera verticality will employ micro-servo switches which will automatically correct the camera should it deviate from the vertical by more than a pre-determined amount. In such a system there should be such refinements as zoom lenses for the camera, an omni-directional antenna, and possibly an air-to-ground chart recording distance measuring system, which will reduce anomalies, and possible errors inherent in the existing equipment.

In all of these advancements there is a danger of producing sophisticated equipment which requires continual field maintenance, and the presence of a fully qualified electronics technician.

If the prototype equipment produces positional control to the required accuracy it may well be desirable to restrict the system to existing equipment thereby providing an economical method of obtaining control over difficult and virtually inaccessible terrain. The comforting thought about the existing system is that with small capital outlay and with facilities for chartering helicopters, it is possible to obtain survey control in virtually inaccessible areas at a fraction of the cost and time taken by conventional methods.

TABLE 1

SUMMARY OF OBSERVATIONS
AIRBORNE SURVEY CONTROL SYSTEM

TRIALS AREA: SCHOOL OF MILITARY SURVEY, BONEGILLA,
VICTORIA, AUSTRALIA

PROJECTION: TRANSVERSE MERCATOR SPHEROID: CLARKE 1858

HORIZONTAL DATUM: SYDNEY OBSERVATORY LAT 33° 51' 41" .105
Long 151° 12' 17" .85E

VERTICAL DATUM: LWM HOBSON BAY, N.S.W.

The Ground Zero in each case was BONEGILLA PEG No 1 the co-ordinates of which are:

Eastings 499 472.13 yds
Northings 540.255.56 yds

Obs. Serial	Observed from Stations	ΔE Yds	ΔN Yds	Number of pointings and distances measured
1	Lady Franklin and Loka	-1.05	-3.51	18
2	Lady Franklin and PM21	+3.80	-3.80	109
3	Talgarno and PM21	+2.31	+3.2	6
4	Huon No 2 and Whytes	-0.46	+1.02	46
5	Houn No 2 and Whytes	+0.58	-0.2	6
6	Huon No 2 and Whytes	-0.48	+1.1	38
7	Huon No 2 and Whytes	-0.86	+0.64	36
8	Huon No 2 and Whytes	-1.07	+0.89	29
		Distance to Ground Zero	Height Value	
Lady Franklin		16 miles	1792 feet	
Loka		19 miles	2187 feet	
Talgarno		7 miles	2116 feet	
PM21		12 miles	1970 feet	
Huon No 2		6 miles	1480 feet	
Whytes		4 miles	702 feet	

APPLICATION OF AERODIST MEASURING EQUIPMENT
TO MAPPING CONTROL

BY

Major E. U. ANDERSON, Royal Australian Survey Corps

ABSTRACT

This paper deals with the employment of 3 Channel Aerodist equipment in PAPUA and NEW GUINEA during the period 1964-66, and the proposed employment of it in ARNHEM LAND IN 1967.

INTRODUCTION

1. 'Aerodist' is an electronic distance measuring equipment that continuously measures the range between a master unit in an aircraft and one, two, or three remote units on the ground. It enables the distances to be measured between ground points that are not in line of sight of each other, or a ground point or aircraft to be fixed with reference to two known ground points.
2. In Papua New Guinea where optical lines of sight are difficult to obtain due to dense jungle and continuous cloud conditions, Aerodist has proved particularly economical, and has provided results of suitable accuracy, in establishing rapid horizontal control over extensive areas for medium scale mapping. Conventional triangulation or traverse in such areas entails time consuming, major clearing commitments, to be followed almost immediately by instrumental observations so as to avoid jungle regrowth problems. Aerodist patterns can normally be designed to take advantage of natural clearings, air strips, river sandbanks, rock hilltops etc and obviate the majority of clearing. Ground movement in Western Papua New Guinea is very difficult and extremely slow, by foot track, so that helicopters are essential for movement of ground station equipment and personnel to ensure that repositioning of ground stations keeps pace with the speed of measurement possible with Aerodist.
3. A first order geodetic survey of Papua New Guinea was completed in 1965 and the Aerodist Net is to be adjusted to this framework (See Fig 1).

CHARACTERISTICS OF AERODIST

4. The Aerodist equipment generally comprises three channels, although two channels are sufficient for single line measurement techniques. The master units are installed in an aircraft and the corresponding remotes of each channel are positioned on ground stations. Simultaneous measurements can be made from the aircraft to up to three remotes of differing channel frequencies. For simple reference the channels are called RED, WHITE and BLUE. The third channel is necessary only when controlled photography (i.e. fixing the aircraft position) is envisaged, but it may also be used in combination with either of the other two channels in conventional trilateration. The equipment provides a continuous chart recording of ranges between the aircraft and the relevant ground stations. The frequencies of the carrier wave are in the 1200 to 1500 Mc/s band.

Channel Frequencies

Colour	Master Freq	IF	Remote Freq
RED	1298	34.65	1263.35
WHITE	1390	29.20	1360.80
BLUE	1218	31.50	1249.50

OPERATIONAL TECHNIQUES

Line Crossing

5. Simple line measurements are normally made by flying for a distance of two or three miles backwards and forward across the line joining two remote stations, using two channels of the equipment. The sum of the two distances, in any one crossing, will become minimum when the aircraft is in line between the two ground stations. The two minima will occur simultaneously when the aircraft flies at right angles to the line between two ground stations. Although it is not essential to fly exactly at right angles, it is important that the flight path during crossings is straight and level, as any deviation will cause error to the reduced distance. (Figure 11A)

6. The resultant slope distances, through the aircraft station, for each of the line crossings, may then be reduced graphically by plotting the sums of the measurements through their respective minima, or computed mathematically.

Geometry

7. The Aerodist equipment measures the slope distances from aircraft to ground stations (Figure 11 B). The absolute heights of the aircraft and the ground stations are therefore required for the reduction of the sea level distance. They may be obtained by simultaneously taking altimeter readings at the aircraft and ground stations at the instant of the line crossing. The altimeter in the aircraft should be connected to a static line and frequently indexed by comparison with Aerodist heights, measured vertically to a remote station of known height, whilst flying at the approximate altitude of the line crossing. The absolute heights of the ground stations may be established by separate altimeter heighting techniques, or higher order levelling.

Horizontal Control Pattern

8. Initially, in PAPUA-NEW GUINEA, it was intended to establish a regular 30 minute pattern of points by Aerodist for photo control, but due to the nature of the terrain, and the random photographic cover, networks for adjustment had to be treated separately from those for detailed photo control. The main network was designed in longer lengths, using open ground such as air fields, kunai patches etc, for remote stations and secondary connections were made from these main stations to the specific location of points required to control the photography. It should be stated that the terrain in the border area ranges from palm covered swamps and rain forest, through kunai slopes, low jungle covered hills, large rivers with some sandbanks, to peaks of 12000 feet and then large tracts of savannah covered flats with very occasional clearings.

Main Adjustment Network

10. The main network was designed to contain as many redundant lines as possible, and be connected to as many first order geodetic stations as possible. This simplified the solution of ambiguities resulting from the use of scaled position from small scale maps in reduction of line measurements. The main stations were chosen as far as possible on airfields because they provided access by fixed wing aircraft, as well as helicopter, and the vertical clearances for Aerodist lines of sight were good. Telescopic towers, up to 70 feet high, were also used to raise the antenna of the remote instrument clear of local obstructions. All stations were targetted and then photographed by the Aerodist aircraft. The longest line planned was 150 miles, and signal strength was excellent, indicating that this was not the limit. The shortest line, used for fourth order connection, was 10 miles, but index error and inaccuracies in ground station and aircraft heights significantly reduces accuracy on short lines. The average length of line planned was 50-60 miles although many lines exceeded 100 miles. The targets were white plastic sheets, each 10 ft. x 4 ft, laid in the form of a cross about the ground mark. All stations were additionally identified on the survey photography by ground parties.

AERODIST CONTROL PAPUA—NEW GUINEA 1964—5—6 FIGURE I

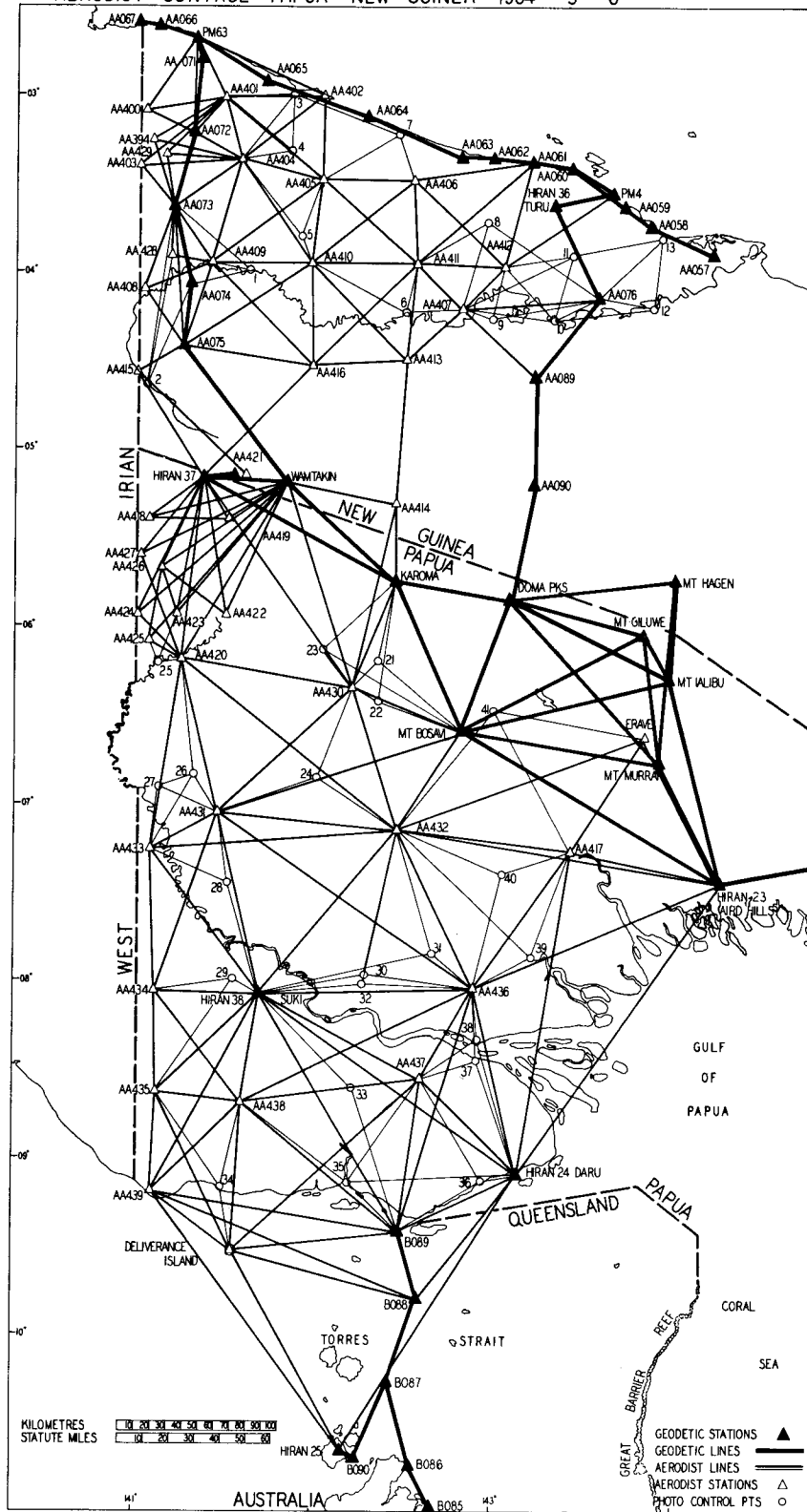

11. The lines forming the main network were measured by a minimum of 5 crossings, at an altitude of between 8,000 and 10,000 feet. The position of the crossings along the line was usually central, although not essentially so, and the point of each crossing was deliberately varied to sample, as far as possible, the meteorological conditions along the line. The altitude of 8,000-10,000 feet was dictated by the height of the terrain, vertical angle of clearance from ground station, and cloud. Normally a height range of 3-7000 feet above terrain is the optimum, dependent of course on the length of line. The best altitude is the lowest height at which a good signal is received.

12. The photographic cover of PAPUA-NEW GUINEA is irregular and disjointed due to the continuous prevalence of cloud. In order to design a control pattern for photogrammetric adjustment, a composite mosaic of all available photography was assembled. The best of the East/West and North/South runs were selected to form the framework for ultimate strip adjustment and control was positioned accordingly. These points were selected at villages, airstrips, in river beds or any natural clearings, where possible.

13. Whereas the selected photo strips were to be controlled and adjusted numerically, the areas contained within these strips were to be adjusted and plotted by multiplex bridging and semi graphical means, so that an extra distribution of heights was required within these areas.

14. The accurate identification of the ground control on the survey photography demanded great care and attention, mainly to avoid gross error. For this reason, as stated earlier, all points were identified on the survey photographs by ground inspection, and in addition, were targetted and photographed individually by the Aerodist aircraft. Because of the sporadic photographic weather it was not feasible to pre-target before survey photography was taken.

15. The lines to the photo control points were measured with a minimum of three crossings from each of at least three main stations, by the line crossing technique. Supplementary heighting of all Aerodist stations and strip and block control was obtained by barometric means - by helicopter.

ORGANISATION OF THE PROJECT

Planning

16. Detailed planning for such a project is of utmost importance. Due to the intense use of aircraft, fuel must be pre-positioned if the project is to run smoothly. Stores and equipment must be grouped, weighed and tested. Registered and unregistered airfield location and classification must be known. The technical plan must be clearly understood by all technical staff involved and aircrews briefed thoroughly.

Manpower

17. Altogether about 50 men, including aircrews, were employed on the project, and the outline organisation is shown in Figure 111. An Aerodist remote party of two men, with their equipment can normally be moved in two light helicopter lifts, depending upon distance and altitude of their stations above sea level. The Aerodist aircraft crew comprised pilot, navigator, camera operator Aerodist operator, meteorological data recorder and a co-ordinator who controlled the operational flying and the air to ground communications to all stations. Use of a smaller and less complicated aircraft of course would reduce the crew required. Six personnel were required to examine charts as they became available to ensure that measurements were acceptable and to keep pace with the measurement rate.

18. The administrative staff required to support the project amounted to six. Two radio operators were required to maintain continuous contact during daylight hours with forward stations and aircraft operating over mountainous jungle terrain in bad weather conditions.

FIGURE II

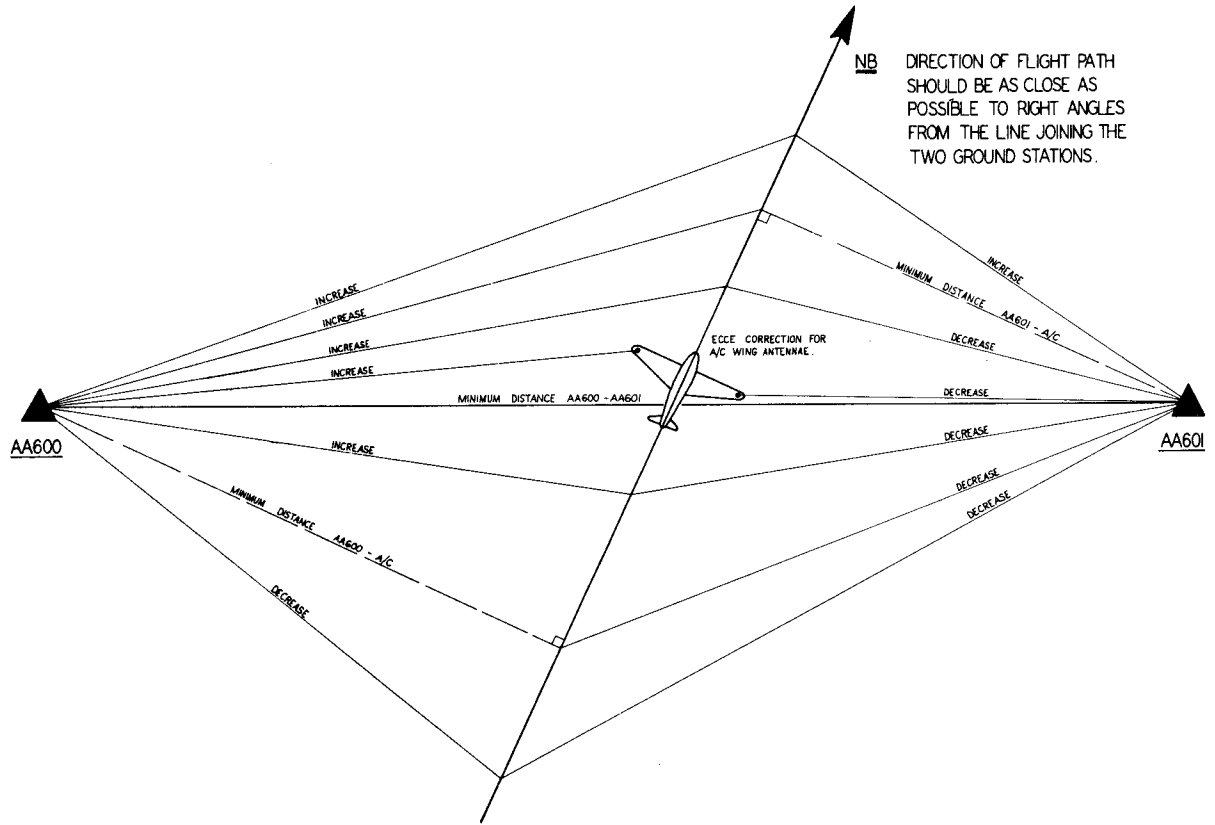

PLAN (A)

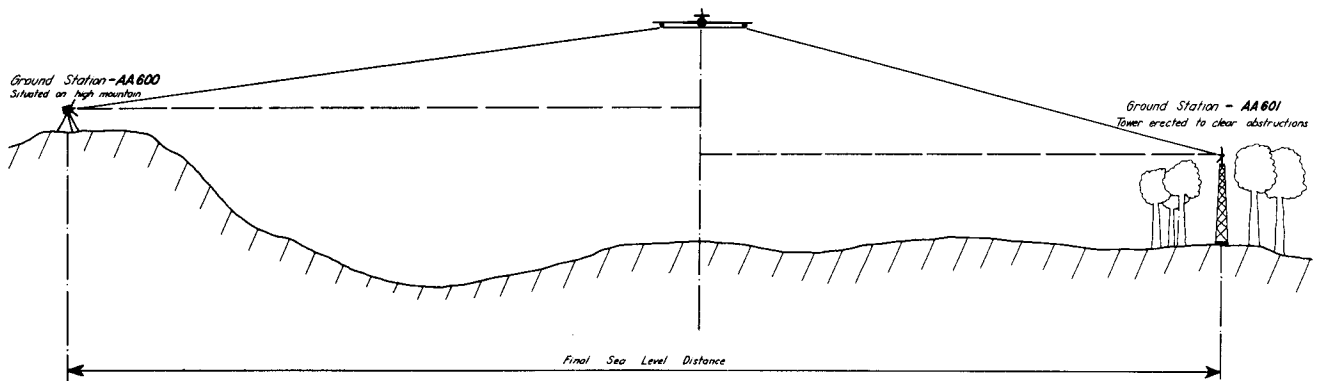

ELEVATION (B)

GEOMETRY OF LINE CROSSING TECHNIQUE

SUMMARY OF OUTPUT

19. In the main trilateration network, 45 points were fixed, and from these a further 34 photo control points were established. 149 lines were measured (5 crossings per line) in the main net, and 103 lines (3 crossings per line) to photo control points. (See Figure 1). This was accomplished in a total of eight months field effort. Altogether, the control so established provided data for the production of 77 maps at a scale of 1 in 100,000, or 46,000 square miles approximately.
20. The rate of measurement by Aerodist depends largely on the time taken to fly from the aircraft base to the operations area, from one line to the next, and the number of crossings per line; the rate of progress of the project depends upon weather conditions, the nature of the terrain, and the means of movement, which dictate the rate at which the ground parties can be maintained and repositioned. One main line of 5 crossings can be measured in as little as 15 minutes flying over the line and a subsidiary line of 3 crossings in 7 minutes when conditions are satisfactory.
21. The overall accuracy of the instrument is expressed by the manufacturers as plus or minus 1 metre plus or minus 1 part in 100,000 of the distance. This has been shown to be possible by comparison of Aerodist measurements with known lines, where elevations of remote stations were accurately fixed. In Papua New Guinea where there is no basic level network and long range barometer techniques have been used, the accuracy is naturally expected to fall away.
22. Provisional results of a rectangular adjustment are shown in Annexures A and B, but these values will be re-examined for ambiguities before finally passing on to a more rigorous spheroidal adjustment. Positional accuracy, at this provisional stage of the adjustment is about 5 or 6 metres. Annex C shows some provisional comparisons with Hiran measurements and computed Geodetic lengths, these also are yet to be checked for ambiguities.
23. In the application of Aerodist to mapping control in Papua and New Guinea, two important points arise, namely
- a. Aerodist has provided a means of establishing photogrammetric control in the otherwise inaccessible terrain and clouded conditions, such as those which prevail in Papua and New Guinea.
 - b. Aerodist has provided medium scale mapping accuracies when operated under the conditions which prevail in Papua and New Guinea.

PROPOSED TECHNIQUES IN 1967

General Comparisons

24. By comparisons with Papua and New Guinea the better conditions of terrain and weather characteristics in Arnhem Land will permit improved techniques such that greater accuracy in the Geodetic sense may be achieved, as well as producing photogrammetric control for medium scale mapping economically.
25. Refinements to previous techniques will reduce the inherent errors in aircraft flight path and elevation, ground elevation, index of refraction and ground swing, and more comparisons will be made in an effort to identify a value for indexing.
26. The general horizontal control pattern will be stronger because of the systematic form of the block photography, and the resultant photogrammetric adjustment will be stronger because of the systematic symmetry of control.

FIGURE III

ORGANISATION NEW GUINEA AERODIST PROJECT

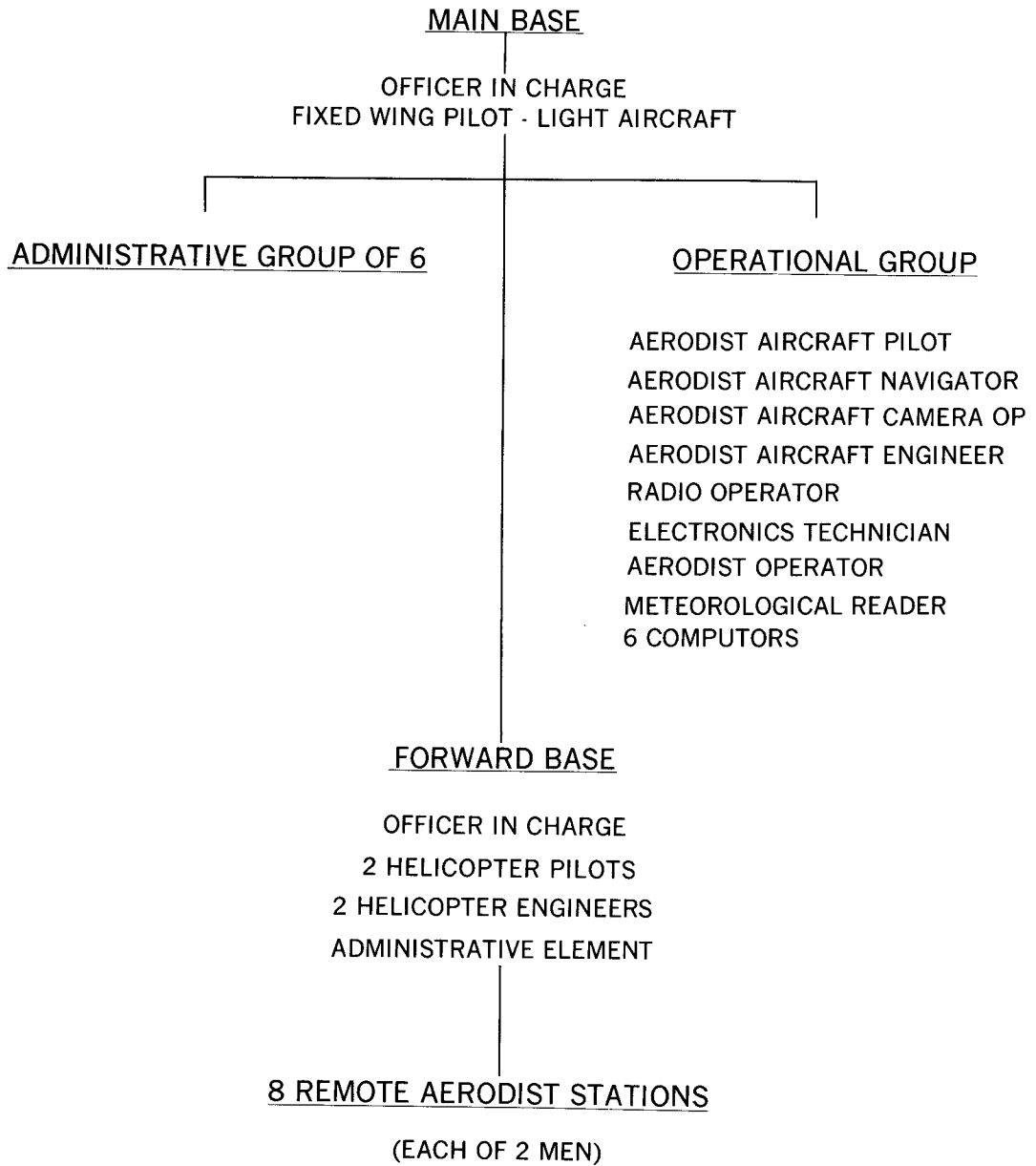

Horizontal Control Pattern

27. The Main Geodetic Network of Aerodist adjustment will be designed as braced quadrilaterals which conform to the graticule of the 1:250,000 map series. Block superwide angle photography also conforms to the 1:250,000 map format. A block is normally flown in East-West strips at an altitude of 25,000 feet above Mean Sea Level. Eight or nine runs of approximately forty pictures cover a unit 1:250,000 area which is one degree thirty minutes of longitude by one degree of latitude. BERVOETS nine control points method of horizontal block adjustment is currently adopted for the photogrammetric adjustment.

28. The secondary network of Aerodist adjustment will be designed to co-ordinate the remaining five control points required in addition to the four Geodetic corner points of the photogrammetric block. These additional five points will occur in the centre of the block and in the mid point of each side of the surrounding graticule. Random points for irregular coastal and off-shore island forms, of course, must be treated independantly as far as any flight planning and photogrammetric adjustment is concerned, but in principle an intersection of three lines measured from either first order or main aerodist stations would apply.

Broad Specifications

29. The Main Geodetic Network of lines will be measured by two sets of six crossings. Each pair of crossings will be approximately 100 metres apart in altitude and each set will be 10 miles apart in the length of the line. They will be flown at about the mid point of the line and at the lowest workable altitude.

30. The Secondary network of lines will be measured by one set of six crossings and each pair of crossings will be 200 metres apart in altitude. They will be flown as near as possible to the midpoint of the line at the lowest workable altitude

31. Detailed specifications, which are not considered relevant to this paper, will also apply to the techniques concerning the refinements outlined in para 25.

CONCLUSIONS

32. Some of the more important lessons learned from experience with Aerodist over the last three years are :-

- a. An area of operations should be sufficiently extensive to warrant the effort of mounting a major control project.
- b. The main Aerodist trilateration for adjustment within the geodetic framework, and the supplementary photo control for photogrammetric adjustment, should be planned and measured conjointly, though designed for different purposes.
- c. The detailed planning of the administrative and logistic support for an Aerodist project is of utmost importance.
- d. The rate of repositioning the ground stations must be in balance with the rate of the Aerodist measurements.
- e. Sufficient computers must be available in the field to prove line measurement charts before leaving the area.
- f. A two channel Aerodist system would normally be sufficient for line measurement techniques.
- g. The accuracy of the system is within the manufacturers stated limits subject to conditions stated previously.

OPERATION OF AERODIST DISTANCE MEASURING EQUIPMENT
IN PAPUA NEW GUINEA

AERODIST ADJUSTMENT – PAPUA AND NEW GUINEA
SUMMARY OF REDUCED AND ADJUSTED MEASUREMENTS
PROVISIONAL VALUES – SEPIK NET ADJUSTMENT

Spheroid: ANS (160)
 Projection: UTM (Zone 54)
 Datum: Horizontal: Johnston origin
 Vertical: MSL
 Unit: Metres

LINE	Reduced Measurement	Number of Measures	Range from Mean	Adj Corrtm and parts ratio	Adjusted Length
AA 405			+6.40	+0.39	
AA 410	52 744.27	8	-4.25	13 525	52 744.66
AA 404			+1.60	-9.17	
AA 405	51 744.06	7	-3.44	5 642	51 734.89
AA 073			+3.29	-2.46	
AA 404	49 338.84	6	-3.72	20 055	49 336.38
AA 410			+5.27	-9.67	
AA 409	61 500.75	8	-7.06	6 359	61 491.08
AA 404			+2.02	-7.99	
AA 409	64 469.30	6	-2.26	8 068	64 461.31
AA 404			+1.19	-7.32	
AA 410	77 665.07	6	-1.92	10 609	77 657.75
AA 073			+2.41	-9.38	
AA 409	42 791.90	7	-2.09	4 561	42 782.52
AA 411			+2.72	-20.80	
AA 410	56 332.10	4	-5.20	2 707	56 311.30
AA 406			+1.38	-1.09	
AA 410	81 077.43	6	-1.11	74 381	81 076.34
AA 406			+2.85	-0.06	
AA 411	52 698.67	5	-5.79	878 160	52 698.61
AA 405			+2.86	-21.54	
AA 406	55 535.08	4	-4.72	2 577	55 513.54
AA 405			+4.33	+3.55	
AA 411	72 369.91	7	-7.03	20 386	72 373.46

AA 405			+3.15	-8.05	
AA 409	84 554.48	8	-4.09	10 503	84 546.43
AA 406			+7.40	-22.03	
AA 061	73 624.01	5	-5.40	3 341	73 601.98
AA 406			+2.09	-0.61	
AA 412	79 980.40	6	-1.07	131 114	79 979.79
AA 411			+6.29	-0.32	
AA 412	57 653.67	5	-6.78	180 167	57 653.35
AA 411			+1.55	-0.47	
AA 061	97 190.39	4	-1.50	206 787	97 189.92
AA 394			+2.48	-3.94	
AA 401	54 184.02	5	-3.34	13 751	54 180.08
AA 394			+4.25	+4.56	
AA 404	56 933.71	7	-5.52	12 486	56 938.27
AA 394			+5.55	-3.24	
AA 073	41 255.20	5	-4.41	12 732	41 251.96
AA 429			+6.71	-2.21	
AA 401	50 057.26	5	-9.41	22 649	50 055.04
AA 429			+0.59	+2.03	
AA 404	48 411.21	5	-1.58	23 848	48 413.24
AA 429			+2.81	-1.81	
AA 073	35 416.49	5	-2.60	19 567	35 414.68
AA 403			+2.80	-0.05	
AA 401	66 881.62	5	-4.39	1 337 631	66 881.57
AA 403			+3.18	+0.06	
AA 404	60 573.71	7	-3.88	1 009 563	60 573.77
AA 403			+8.08	-0.04	
AA 073	30 568.38	7	-4.12	764 209	30 568.34
AA 401			+2.84	-4.84	
AA 405	79 581.46	9	-2.76	16 441	79 576.62
AA 428			+3.89	00	
AA 409	29 307.01	5	-3.31		29 307.01
AA 416			+4.44	-2.85	
HIRAN 37	99 778.23	7	-3.96	35 009	99 775.38
AA 428				00	
AA 073	28 727.64	TELLE			28 727.64
AA 412			+1.40	-3.33	
PM 4	88 414.90	7	-2.21	26 550	88 411.57
AA 412			+0.62	+0.50	
AA 061	69 037.69	3	-0.40	138 076	69 038.19

AA 407					-2.65	
AA 412	32 403.60	TELLE			12 227	32 400.95
AA 407					-5.15	
AA 413	44 644.82	TELLE			8 668	44 639.67
AA 407				+1.87	-9.41	
AA 411	44 740.81	5		-1.94	4 754	44 731.40
AA 407					-7.75	
AA 089	61 789.70	TELLE			7 972	61 781.95
AA 407					-3.38	
AA 076	90 750.71	TELLE			26 848	90 747.33
PM 63				+1.18	-11.60	
AA 401	42 842.85	5		-2.36	3 692	42 831.25
AA 072				+1.91	+3.84	
AA 401	28 743.40	4		-3.78	7 486	28 747.24
AA 072				+25.46	00	
AA 400	32 587.99	12		-6.26		32 587.99
PM 63				+5.78	00	
AA 400	50 810.29	5		-4.79		50 810.29
AA 401				+4.33	-2.39	
AA 402	61 443.28	6		-3.78	25 707	61 440.89
AA 072				+4.33	-19.00	
AA 404	36 216.20	6		-3.78	1 905	36 197.20
AA 401				+5.93	-6.51	
AA 404	41 760.57	9		-5.12	6 414	41 754.06
AA 402				+3.02	-2.33	
AA 404	65 450.39	6		-5.87	28 089	65 448.06
AA 075				+10.17	-13.54	
AA 409	54 187.46	5		-9.30	4 001	54 173.92
AA 075				+16.16	+10.77	
AA 408	44 190.83	7		-13.34	4 104	44 201.60
AA 073				+1.54	+13.63	
AA 408	54 726.05	6		-2.50	4 016	54 739.68
AA 410				+3.79	-11.15	
AA 416	62 164.79	5		-3.24	5 574	62 153.64
AA 416				+2.17	+6.70	
AA 075	81 883.14	6		-2.59	12 222	81 889.84
AA 416				+3.89	-4.62	
AA 409	89 252.05	7		-3.18	19 318	89 247.43
AA 075				+2.85	-2.76	
AA 410	93 905.44	6		-1.56	34 023	93 902.68

AA 411			+2.15	-3.46	
AA 413	58 254.54	6	-1.82	16 836	58 251.08
AA 413			+0.64	-9.72	
AA 416	53 588.69	6	-4.20	5 512	53 578.97
AA 413			+6.94	+8.13	
AA 410	79 502.63	9	-2.51	9 779	79 510.76
AA 416			+8.04	+16.30	
AA 411	83 364.00	5	-6.29	5 115	83 380.30
PM 63			+3.25	+4.60	
AA 402	89 518.26	6	-4.36	19 461	89 522.86
AA 409			+2.41	-12.21	
AA 408	47 416.47	6	-1.45	3 882	47 404.26
AA 402			+5.21	+3.40	
AA 405	51 593.20	5	-9.78	15 175	51 596.60

OPERATION OF AERODIST DISTANCE MEASURING EQUIPMENT
IN PAPUA NEW GUINEA

AERODIST ADJUSTMENT – PAPUA AND NEW GUINEA
SUMMARY OF REDUCED AND ADJUSTED MEASUREMENTS
PROVISIONAL VALUES – FLY NET ADJUSTMENT

Spheroid: ANS (160)
 Projection: UTM (Zone 54)
 Datum: Horizontal: Johnston origin
 Vertical: MSL
 Unit: Metres

LINE	Reduced Measurement	Number of Measures	Range from Mean	Adj Corrn and parts ratio	Adjusted Length
HIRAN 25 AA 439	201 030.17	5	+1.69 -2.82	-1.74 1 15 534	201 028.43
HIRAN 25 DELIVERANCE	143 525.10	10	+8.88 -6.13	-3.02 47 524	143 522.08
HIRAN 25 AA 440	204 645.13	4	+1.27 -1.34	+3.23 63 359	204 648.36
B 088 DELIVERANCE	119 664.90	4	+3.25 -1.61	-6.35 18 844	119 658.55
B 088 AA 439	173 036.03	6	+1.36 -2.75	+5.86 29 529	173 041.89
B 088 AA 440	98 706.48	5	+2.04 -1.66	-0.24 411 276	98 706.24
B 089 AA 440	82 754.95	5	+2.76 -3.12	-1.73 47 834	82 752.58
B 089 DELIVERANCE	106 820.95	4	+2.13 -3.36	-3.67 29 106	106 817.28
B 089 AA 439	151 617.07	4	+2.02 -0.27	+2.02 75 059	151 619.09
B 089 AA 438	125 883.48	4	+3.73 -2.29	-8.41 14 967	125 875.07
B 089 AA 437	97 790.33	4	+10.25 -10.79	-10.00 9 778	97 780.33
B 089 AA 436	158 279.94	5	+8.54 -6.90	-4.99 31 718	158 274.95
AA 439 DELIVERANCE	59 182.79	5	+2.09 -2.91	-13.03 4 541	59 169.76

AA 439			+1.14	-16.12	
AA 435	59 439.50	6	-2.41	3 686	59 423.38
AA 439			+2.53	+14.06	
HIRAN 38	135 789.56	5	-0.84	9 659	135 803.63
AA 439			+0.24	-6.28	
AA 438	69 854.08	4	-0.45	11 122	69 847.80
AA 435			+0.84	+6.75	
DELIVERANCE	111 005.19	6	-2.81	16 446	111 011.94
AA 438			+2.07	-5.59	
DELIVERANCE	90 142.93	4	-1.55	16 125	90 137.34
AA 437			+4.80	+7.22	
DELIVERANCE	160 825.18	6	-6.73	22 276	160 832.40
AA 437			+1.68	-3.48	
AA 438	112 655.00	5	-1.64	32 371	112 651.52
AA 435			+0.69	-6.39	
AA 438	56 021.10	5	-0.88	8 766	56 014.71
HIRAN 38				+1.83	
AA 440	199 528.50	1		109 033	199 530.33
AA 437			+0.87	-0.16	
AA 440	85 764.29	5	-1.44	536 026	85 764.13
AA 437			+0.72	-3.54	
HIRAN 38	115 676.51	6	-1.11	32 676	115 672.97
AA 438			+3.06	-21.51	
HIRAN 38	74 103.88	4	-3.18	3 444	74 082.37
AA 435			+5.56	+8.17	
HIRAN 38	89 908.56	8	-5.83	11 006	89 916.73
AA 435			+5.86	-16.93	
AA 434	63 829.57	6	-8.79	3 769	63 812.64
AA 434			+13.60	-4.40	
HIRAN 38	60 009.51	5	-9.33	13 638	60 005.10
AA 434			+0.87	+6.47	
AA 438	89 948.97	5	-0.42	13 903	89 955.44
AA 434			+1.55	-7.48	
AA 433	88 639.25	5	-1.03	11 849	88 631.77
AA 433			+7.75	-7.33	
AA 431	51 210.80	5	-5.05	6 985	51 203.47
AA 433			+1.98	+4.89	
HIRAN 38	113 218.47	5	-2.06	23 154	113 223.36
AA 434			+1.06	-4.36	
AA 431	119 089.26	5	-1.13	27 313	119 084.90
AA 431			+4.80	-8.42	
HIRAN 38	117 917.12	6	-3.84	14 003	117 908.70

AA 438			+4.52	+5.72	
AA 436	161 049.05	6	-0.64	28 156	161 054.78
AA 440			+1.47	-0.84	
AA 436	118 362.56	5	-2.07	140 907	118 361.72
AA 437			+1.41	-4.71	
AA 436	63 607.24	5	-2.00	13 504	63 602.53
HIRAN 38			+2.36	-2.74	
AA 436	134 053.47	6	-3.15	48 924	134 050.73
AA 440			+1.15	+2.11	
AIRD HILLS (DLS)	221 239.63	4	-1.23	104 854	221 241.74
AA 436			+0.99	+1.03	
AIRD HILLS (DLS)	169 763.54	3	-0.78	164 820	169 764.57
AA 436			+1.81	+2.33	
AA 431	197 208.59	6	-4.13	84 640	197 210.92
HIRAN 38			+1.54	-2.62	
AA 432	124 479.55	4	-1.19	47 510	124 476.93
AA 433			+1.62	+4.13	
AA 432	150 742.21	5	-1.14	36 500	150 746.35
AA 431			+1.99	-5.11	
AA 432	108 443.56	6	-2.49	21 221	108 438.45
AA 433			+0.83	-0.02	
AA 420	126 010.55	4	-0.50	6 300 527	126 010.53
AA 431			+2.39	-12.27	
AA 420	100 341.61	5	-2.05	8 177	100 329.34
AA 431			+1.99	-2.12	
NM/J/28	154 585.73	6	-2.79	72 896	154 583.61
AA 432				-3.34	
NM/J/28	78 324.61	TELLE		23 449	78 321.27
AA 432			+0.63	-5.21	
AA 436	109 122.11	5	-1.53	20 944	109 116.90
AA 432			+0.46	+6.20	
AIRD HILLS (DLS)	211 759.51	3	-0.81	34 156	211 765.71
AA 432			+2.07	-10.88	
AA 417	112 076.31	5	-1.78	10 300	112 065.43
AA 436			+2.04	-5.15	
AA 417	104 004.98	4	-0.83	20 194	103 999.93
AA 417			+1.37	-10.33	
AIRD HILLS (DLS)	100 094.47	5	-0.86	9 689	100 084.14
ERAVE			+2.54	+3.79	
AIRD HILLS (DLS)	105 904.02	7	-3.39	27 944	105 907.81
ERAVE			+2.52	-6.61	
AA 417	87 761.50	5	-3.13	13 276	87 754.89

AA 420			+2.56	+2.35	
AA 430	105 279.68	6	-1.70	44 801	105 282.03
AA 420			+1.18	+0.35	
AA 432	174 339.90	7	-1.02	498 115	174 340.25
HIRAN 37			+1.61	-1.12	
AA 418	42 817.17	5	-1.09	38 229	42 816.05
AA 418			+3.26	-1.51	
AA 419	50 412.65	6	-3.32	33 385	50 411.14
HIRAN 37			+4.32	+0.80	
AA 419	29 731.70	3	-1.49	37 166	29 732.50
NM/J/30			+18.96	-1.28	
AA 419	45 461.99	4	-25.05	35 516	45 460.71
NM/J/30			+2.20	+2.50	
AA 418	92 129.09	4	-1.29	36 853	92 131.59
AA 427			+1.15	+0.72	
NM/J/30	103 843.71	4	-3.84	144 227	103 843.71
AA 427			+1.46	-0.81	
HIRAN 37	64 224.44	5	-1.46	79 288	64 223.63
AA 426			+6.72	-1.41	
HIRAN 37	63 368.74	7	-2.92	44 941	63 367.33
AA 426			+2.43	+0.59	
NM/J/30	96 952.58	5	-5.16	164 327	96 953.17
AA 426			+2.74	-0.80	
AA 422	49 274.50	4	-4.55	61 592	49 273.70
NM/J/30			+0.52	-0.99	
AA 422	90 448.06	4	-0.43	91 361	90 447.07
NM/J/30			+3.41	+0.88	
AA 423	102 671.56	6	-1.84	116 673	102 672.44
NM/J/30			+1.77	+1.24	
AA 424	122 885.07	7	-1.45	99 102	122 886.31
AA 426			+3.38	+0.74	
AA 423	28 660.55	4	-4.38	38 731	28 661.29
HIRAN 37			+1.61	-1.24	
AA 424	92 351.14	4	-2.33	74 476	92 349.90
AA 432			+2.02	-5.17	
AA 430	102 332.51	8	-3.02	19 793	102 327.34
NM/J/28			+1.58	+1.31	
AA 430	73 061.71	9	-1.09	55 773	73 063.02
NM/J/29				-4.52	
AA 430	69 371.50	TELLE		15 347	69 366.98
NM/J/30			+1.70	+1.06	
AA 425	129 928.87	5	-2.80	122 575	129 929.93
AA 425			+2.78	-0.96	
AA 426	44 540.43	3	-1.96	46 395	44 539.47

HIRAN 37			+0.08	-10.39	
AA 420	107 935.55	5	-3.04	10 387	107 925.16
NM/J/30			+7.66	-0.23	
AA 420	121 252.43	6	-2.51	527 183	121 252.20
AA 420			+3.95	-0.53	
AA 424	39 064.94	4	-3.95	73 706	39 064.41
AA 420			+1.39	-0.36	
AA 427	63 007.61	3	-0.61	175 020	63 007.25
HIRAN 37			+0.22	+0.54	
AA 430	157 189.41	3	-0.23	291 093	157 189.95
AA 431			+2.22	-4.44	
AA 430	113 915.60	8	-1.96	25 656	113 911.16
AA 425			+1.33	-0.62	
AA 420	23 282.07	2	-1.33	37 552	23 282.07
NM/J/30			+1.63	-4.49	
AA 430	128 006.29	6	-2.81	28 508	128 001.80
AA 414			+11.99	00	
NM/J/30	68 942.06	6	-10.51		68 942.06
AA 414			+1.50	00	
AA 430	109 315.25	3	-0.98		109 315.25
AA 432			+2.73	+5.84	
ERAVE	172 278.60	2	-2.71	29 501	172 284.44
AA 440			+0.57	-0.08	
AA 417	203 022.57	3	-0.83	2 537 781	203 022.49

OPERATION OF AERODIST DISTANCE MEASURING EQUIPMENT
IN PAPUA NEW GUINEA

SUMMARY OF AERODIST AND GEODETIC COMPARISONS

Spheroid: ANS (160)
 Projection: UTM (Zone 54)
 Datum: Horizontal: Johnston origin
 Vertical: MSL
 Unit: Metres

AERODIST AND HIRAN COMPARISONS

LINE	Numbers of Measurements and Range	Aerodist Reduced Measurement (a)	Hiran Reduced Measurement (b)	Diff and Parts ratio (a)-(b)	Geodetic Adjusted Length (c)	Diff and Parts ratio (a)-(c)
HIRAN 24	4 +1.15	221 444.90	221 443.44	+1.46	221 448.02	-3.12
HIRAN 23	-1.23			151 674		70 977
HIRAN 24	4 +1.27	204 441.26	204 434.09	+7.17	204 438.66	+2.60
HIRAN 25	-1.34			28 512		78 630
HIRAN 24	1	199 506.20	199 492.43	+13.77	199 500.86	+5.34
HIRAN 38				14 487		37 360

AERODIST AND COMPUTED COMPARISONS

LINE	Number of Measurements and Range	Aerodist Reduced Measurement (a)			Geodetic Computed Length (b)	Diff and Parts ratio (a)-(b)
HIRAN 24	5 +3.03	82 562.94			82 552.34	+10.60
B 089	-3.12					7 788
HIRAN 24	5 +2.04	98 500.04			98 492.99	+7.05
B 088	-1.66					13 971
HIRAN 38	5 +3.98	176 135.67			176 132.35	+3.32
B 089	-5.13					53 052
PM 63	6 +3.21	58 634.97			58 630.86	+4.11
AA 072	-3.05					14 265
AA 073	6 +2.38	86 398.28			86 392.20	+6.08
AA 075	-2.71					14 209
AA 061	3 +0.62	69 037.69			69 027.55	+10.14
AA 412	-0.50					6 807
PM 4	7 +1.40	88 414.90			88 411.51	+3.39
AA 412	-2.21					26 080

PRESENTATION AND DISCUSSION

ON PAPERS NO. 9, 10, 11.

Chairman: Mr. A.G. Bomford, Division of National Mapping.

J.D. LINES introduced his paper "Control Surveys for 1/100 000 scale mapping" by saying that in 1966 the 540 sheets of the 1/250 000 scale series had been completed. These sheets provide a complete coverage of Australia and it is hoped that all sheets will be printed by the end of 1967.

The next Commonwealth mapping project is the production of a 1/100 000 series over a ten year period. Compilation is to be carried out at this scale but only about 40% of those covering the more inhabited areas, will be published at this scale and the remainder at 1/250 000. The time target provides a strong incentive and the methods to be used constitute a challenge in planning.

The modern speed of movement, which is possible nowadays, and the new instruments available enable a survey of good quality to be made with great ease. The aerodist method has been selected for this task and in some areas this method will be supplemented by second order tellurometer traversing. Continuous field operation is possible with aerodist measurements and the teething troubles are being overcome as a result of experience gained recently. A standard flight plan is being worked out and spot photography, which consists of photographing a control point from differing heights, will be carried out for each control point to make identification back at headquarters absolutely certain and thus make it unnecessary to send parties over long distances into the field checking identifications.

The reduction of aerodist observations is a big job and a suitable system is being evolved for achieving this automatically. Tests are being carried out to determine the best control patterns to be used and also to determine the maximum possible distance from aerodist observations as this is important in mapping desert areas and fixing offshore islands.

The Airborne Profile Recorder is being used for height control but a laser terrain profiler is being developed in the hope that this will

enable a record of heights and the strip picture of the ground flown over to be shown on one film strip. The Johnson Elevation Meter has been used to a certain extent to check the APR especially in the flatter areas but no ground surveys are proposed for height control. Some consideration is being given to the control of the attitude of the camera in the aircraft.

W. CHILD presented his paper "Australian Developments in the Use of Hovering Helicopters to Establish Survey Control" by saying that this method is an Australian development based on the Airborne Control System being investigated in America.

The American method uses a helicopter hovering over a station at a height of less than 300 feet above the point. The helicopter is held over the station by estimation of verticality but it can not be held within 50 feet of the point vertically above the station. A sight developed to improve this feature was not altogether successful. The maximum distance by this method at which the helicopter could be sighted from the fixed base stations was 17 kilometers.

The Australian requirements were a maximum distance from the fixed base stations of 35 miles and a hovering height of not less than 500 feet above the ground station. An optical sight for enabling the helicopter pilot to stay vertically over the ground point was developed but was found to be insufficiently accurate. A light beam was then tried out to provide a vertical line of sight but this was not altogether satisfactory. The next method tried out was the use of television. A television camera was set up on the ground station so that it gave a vertical line of sight. A television receiver was mounted in the helicopter. The pilot then hovered so that the helicopter in the screen of the TV receiver stayed over the ground mark. This was partially successful until a particular pilot showed that he could hover within 3 feet of the required position for periods of 10 to 20 seconds.

For an inaccessible ground station closed circuit TV was used with camera and receiver both in the aircraft.

E.U. ANDERSON introduced his paper "Application of Aerodist Measuring Equipment to Mapping Control" with the following remarks.

The aerodist system is the airborne version of the tellurometer with the crystals automatically tripped by a tone from the master unit.

The paper deals with experience gained in New Guinea where conditions were extremely difficult. Ground movement was greatly restricted, weather changes occurred very suddenly and existing maps were poor so that planning was hampered. This called for great flexibility and very detailed logistic and administrative support.

It was difficult to achieve the orthodox patterns normally obtained in less difficult terrain. It was necessary to have a sufficiently large number of men on the job to be able to compute the results and to check these quickly.

Accuracy results obtained from this task are provisional but seem to show that they are sufficient for the purpose of making 1/100 000 maps.

It is anticipated that the aerodist system will be much easier to carry out on the mainland of Australia because of the availability of good maps, the flatter country and the more predictable climate.

DISCUSSION

L.A. WHITE asked whether it might be possible to anchor the helicopter in position by means of three stay wires from the ground.

CHILD: This would not be possible as the helicopter veers very suddenly and also is subject to sudden jumps up and down. It is an unstable craft and easily overturned. Also the pilot of a helicopter is averse to hovering close to the ground because he would not have sufficient height to recover if his engine cut out.

J. MITCHELL: What does the antenna system of the aerodist equipment consist of?

LINES: The antenna is very similar to that of the ordinary tellurometer antenna. It consists of a dipole and reflector giving a 70° cone for the master unit and a 30° cone for the remote unit.

A. STOLZ: How far must the criterion be applied that the figure should contain as many redundant lines as possible.

ANDERSON: Redundant measurements are necessary to provide checks but a sense of proportion must be maintained so that some redundancies must be included. This requirement must not be carried to absurd lengths.

J.S. ALLMAN: Has the possibility of altering the aerodist system ever been considered? The master could be placed at one end of the line and a slave unit at the other end and the aircraft should carry two slave units. Thus the total slope distance could be measured as well as one of the two slope distances to the aircraft. The finding of the minimum value would then be simplified and also the aircraft need not fly in a dead straight line.

ANDERSON: This proposed system has not been investigated and the equipment is being used in its present form. There seems to be no advantage in the system proposed. It would be easy to add the two distances obtained at present by some analogue device, and achieve the same effect more simply.

P.V. ANGUS-LEPPAN: Are the points surveyed by aerodist marked so that they can be used in the future?

LINES: Besides the recording of the station positions by spot photography, they are marked by concrete block with witness and reference marks.

K. LEPPERT: Is an azimuth mark provided in the vicinity of the main mark?

LINES: From 1967 an azimuth mark has been provided. This usually consists of a blaze on a tree with a nail and it is usually about 1/4 mile away.

F.H. EDWARDS: How does the aircrew know when a line crossing has been effected?

LINES: No difficulty has been experienced. If the flight is perpendicular to the line, the crossing is seen very easily. If the flight is oblique, this is not so easy but no great difficulty has been encountered.

G. KONECNY: What is the antenna separation in the aircraft and if appreciable, is an eccentricity correction made?

LINES: The antenna separation is about 6 feet and an eccentric correction is made.

LEPPERT: Does the aerodist ground party, when at the station, look after the photo identification of the ground station?

LINES: The marking party prepares the ground mark and spot photography is carried out to make certain of the identification back at headquarters.

J. TRINDER: Are cross strips used together with the Airborne Profile Recorder to determine tilts?

LINES: This is being done as well as strips along the common side overlaps.

G. COCKS: The horizontal control seems to be suitable but the vertical control seems to be somewhat doubtful. Can the speakers comment?

LINES: It was thought that vertical control would be difficult to provide but tests have shown that the vertical control provided will be sufficient for the requirements. The Airborne Profile Recorder will be suitable and the use of a laser profiler does not seem to be necessary. The third order levelling is suitable at present.

EDWARDS: What are the relative accuracies of the Airborne Profiler Recorder and the Laser Profiler?

LINES: The APR requires a five mile stretch of water for calibration and then still gives an error of 20 feet. The latter gives an error of one foot.

STOLZ: Why is the Australian National Spheroid being used instead of the International Spheroid?

LINES: The Australian Spheroid is used because all available information has been used in its determination. The International Spheroid is not a very good one being out of date, and it may well be replaced in the near future by the International Astronomical Spheroid, whose dimensions have been adopted for the Australian National Spheroid.

MITCHELL: How much time is required in the adjustment of the new data? Will the new R.502 series be published in colours?

LINES: The adjustment, because of the powerful computers now available, will not take long, and will not be a factor causing hold-ups in the programme.

Those maps of the new 1/100 000 series which are published, will be in colour.

S. BERVOETS: Will publication be in the metric system?

LINES: The 1/250 000 maps will be on the old system but the 1/100 000 will be on the new spheroid with a metric grid and metric spot heights.

BERVOETS: It would be an advantage if the Aerodist output were in digital rather than graphical form. Is there any possibility that the equipment will be modified?

LINES: The Tellurometer Company has done some work on a digital display but there is hardly enough of a demand to justify the further prosecution of a difficult project.

CHAIRMAN: Can you give some details of the number of people required in the office to keep pace with the aerodist work in the field.

ANDERSON: In the New Guinea network about 100 lines were observed per month. This required 6 to 8 computers in the field for three months to carry out the inspection and the breaking out of the coarse readings. In the office this will need about 10 computers for a period of five months to work out the final readings for the computer input and also to carry out the adjustment.

LEAST SQUARES - THE NEW LOOK.

by

A.G. Bomford.

When one is first taught least squares, one considers unweighted observations for one type of data only, usually angles. Almost at once, one adds in the concept of weights.

We now very frequently have to consider adjustments of quantities of different dimensions, usually angles and distances.

One cannot ignore weights; if one tries to, one is merely saying, implicitly, that one believes that the standard error of angles, on one hand, and distances, on the other, are in the ratio of one second to one foot, or one second to one metre, and different solutions are obtained if the units of length are changed.

Leaving correlation till later, and considering first only observation equations, the problem of weights is immediately solved by dividing each observation equation by the standard error of the observed quantity. If standard errors are not known, it suffices to divide by quantities bearing a constant proportion to the standard errors. In practice standard errors can usually be assessed adequately with little difficulty.

This does two things: it reduces all the observation equations to uniform dimensions, so that the mathematics can proceed meaningfully; and it makes the correct allowance for variation in the accuracy of the observations. One obtains a unique result, regardless of whether distances are in feet, metres, miles or millimetres.

There is an equivalent step for adjustment by condition equations: each column in the condition equations must be multiplied by the standard error of the unknown quantity.

We have now brought the theory of least squares into step with geodetic survey practice about 1965, but two matters

- (1) angles and directions
- (2) satellite computations, where there are vast numbers of observations for very large numbers of unknowns

have revealed the necessity to consider co-variance; and those that can read him, who are few, find that Tienstra has already given the necessary theory.

The drill for dealing with correlated observations will be discussed later in this colloquium. The point I want to emphasise in this discussion is this: to produce a unique least squares solution which can claim to be the most probable solution to our problem, we need

- (1) a set of observations
- (2) a set of variances
- (3) a set of co-variances.

If, either through necessity or carelessness, we omit step (3), we are implicitly assuming all the co-variances are zero.

If we omit step (2), we are implicitly assuming that all our standard errors are in the ratio one to one in the units actually used; and with a change of units, we get a different solution.

The validity of our results depends on the extent to which these implicit assumptions are true. As they depart from the truth, so the solution we obtain becomes increasingly arbitrary, and at some stage becomes worthless. The matter is not trivial: some of the earlier least squares solutions for the co-ordinates of satellite tracking stations on a world datum were worthless, because some co-variances which were far from zero were overlooked.

If one regards least squares merely as a rigmarole for obtaining a consistent set of results from redundant observations, then variances

and co-variances can happily be forgotten. Assuming them to be unity and zero will certainly produce a consistent set of results, but it may be a very arbitrary set. Most people like to regard least squares as a device for obtaining the most probable solution, and nearly everyone would be dismayed if they got a different solution with distances in metres to what they get with distances in feet.

It seems to me that allocating variances can usefully be done in every case, and from now on should never be neglected.

The allocation of co-variances cannot, today, very often be usefully done because we do not yet have any means of assessing them adequately; but we all need to be aware of the theory, to consider what co-variances may exist in our data, take steps where necessary to estimate them, and analyse what errors we are likely to obtain if we neglect them.

Personally, I now regard the concept of "weight" as superfluous, and indeed misleading. I would like to see the theory of least squares rewritten on the above lines, without the word "weight" ever being mentioned, except possibly in a small foot-note, to the effect that "numbers inversely proportional to standard errors were in the past sometimes referred to as weights, but the term is a confusing one which is better avoided".

I suggest that every surveyor who ever has to deal with least squares needs to have a clear concept of the part played in the theory by variances and co-variances, an essential part if the least squares solution is to make any claims to being "the most probable solution". I suggest that all students at universities need to be brought up, from the start, to regard variances and co-variances as an essential part of least squares; they may sometimes, through lack of knowledge, have to be equated to unity and to zero, but they should never be ignored.

LEAST-SQUARE ADJUSTMENT OF OBSERVATIONS

by

J.S. Allman

Abstract. The Parametric and Correlate Methods of adjustment are expressed in matrix notation and the adjustment is carried through to the calculation of the estimated precision and statistical testing. The methods are illustrated by worked examples and adjustment in phases is also shown. Finally, an example is worked using "dissimilar quantities".

1. Introduction

The problem of adjustment of observations has been the subject of numerous publications in recent years. In particular, the advent of electronic distance measuring devices has led to a spate of publications designed to overcome the problem of the adjustment of "dissimilar quantities". The problem of adjustment using derived quantities has also been aired recently.

Accordingly, I feel that the time is ripe for a restatement of the fundamental techniques of the least square adjustment using matrix algebra. Further, the techniques are perfectly general and if rigorously followed, allow for the adjustment of dissimilar quantities, derived quantities, adjustment in phases and continuous adjustment.

As the derivations are covered in classical algebra in many texts (see bibliography) these are not given. The various stages are thus given in matrix algebra without full derivation. To illustrate the methods a

simple example is adjusted by four different methods yielding identical solutions in each case. An example of the adjustment of dissimilar quantities is also included. It should be noted that the same approaches can be used for far more complex adjustments and that this example is illustrative only. No attempt has been made to present the computation in a tabular format for, at this stage, it is more important to obtain a clear understanding of the manipulation. However, it would be a simple matter to select a tabular format once the manipulation is mastered.

2. Fundamentals

In general, the values must be found of a set of variates for which superfluous observations have been made. It is impossible to obtain the "true" values of these variates and hence estimates of the values or "adjusted variates" must be calculated. These estimates may be found in many ways with differing degrees of precision. This paper deals with the Least Square method. The validity of adopting the "Least Square" as the basic criterion is not discussed in this paper. Readers interested in this point are referred to an article entitled "Statistical Properties of Least Square Estimates" (3).

If the variates are denoted as \bar{P}_i

the estimates as P_i

the observations as p_i

the corrections as v_i

where $i = 1, n$ with r redundancies.

then

$$\bar{P}_i \approx P_i = p_i + v_i \quad 1.$$

The precision of each observation is given by its variance σ_i^2 .

Then, in the method of Least Squares the corrections are chosen to satisfy

the relationship that

$$\left[\frac{vv}{\sigma^2} \right] \text{ is a minimum.} \quad 2.$$

In this form, as originally laid down by Gauss, the minimum is a dimensionless quantity since the correction v_i is expressed in the same units as the Standard Deviation σ_i . Generally the variance of the observations will be either unknown or determined by an estimator S_i^2 .

Thus

$$\sigma_i^2 \approx S_i^2 \quad 3.$$

Further, some suitable dimensionless number may be taken as a variance factor S^2 such that

$$S_i^2 = S^2 \cdot g_{ii} \quad \text{where } g_{ii} \text{ is the weight coefficient of} \quad 4.$$

the particular observation

When adjusting similar quantities with similar precision, g_{ii} is frequently taken as unity and S^2 based on previous experience. This leads directly to the same relationship as before. That is, the Least Square Estimates satisfy the relationship that $\left[\frac{vv}{S^2} \right]$ and hence $\left[\frac{vv}{g} \right]$ is a minimum.

So far it has been assumed that the observations were free of correlation. When this is not the case, the minimum relationship becomes more complex but by using matrix notation, the whole adjustment may be conveniently written down. Since the uncorrelated case is merely a special case of the correlated form, the method will be developed for the latter. It should be noted that the use of matrices does not in any way alter the fundamental concepts but merely allows the formidable equations of classical algebra to be expressed concisely and manipulated more easily.

Denoting the various matrices as indicated:-

$$\text{Matrix of Variates } \bar{P} = \begin{vmatrix} \bar{P}_1 \\ \bar{P}_2 \\ \vdots \\ \bar{P}_n \end{vmatrix} \quad 5.$$

$$\text{Matrix of Estimates } P = \begin{vmatrix} P_1 \\ P_2 \\ \vdots \\ P_n \end{vmatrix}, \quad 6.$$

$$\text{Matrix of Observations } p = \begin{vmatrix} p_1 \\ p_2 \\ \vdots \\ p_n \end{vmatrix}, \quad 7.$$

$$\text{Matrix of Corrections } V = \begin{vmatrix} v_1 \\ v_2 \\ \vdots \\ v_n \end{vmatrix}, \quad 8.$$

and the Matrix of Weight Coefficients of the Observations as

$$G = \begin{vmatrix} g_{11} & g_{12} & g_{13} & \cdots & g_{1n} \\ g_{21} & g_{22} & g_{23} & \cdots & g_{2n} \\ \cdots & \cdots & \cdots & \cdots & \cdots \\ g_{n1} & g_{n2} & g_{n3} & \cdots & g_{nn} \end{vmatrix} \quad 9.$$

then $\bar{P} \approx P = p + V$

where V is selected such that $V^T G^{-1} V$ is a minimum M .

3. Mathematical Model

Before proceeding further with the adjustment it is necessary to select the mathematical model on which the adjustment is to be carried out. For example, when the three angles are measured between three triangulation stations on the surface of the earth, the model may be selected in a number of ways.

- (1) A Plane Triangle.
- (2) A Spherical Triangle.
- (3) A Spheroidal Triangle.
- (4) A Spheroidal Triangle with corrections for normal section, elevation and deflection of the vertical.

Each of these models will lead to a slightly different matrix of corrections where the simpler models approximate the more rigorous. A choice must then be made between the various models such that the adjusted values (i. e. the estimates) are sufficiently precise for the particular requirement. It should be noted that the minima will differ for each different model. The better the model the smaller the minimum.

Further, by applying the appropriate transformation to the observations, a lower order model will give identical results to a higher order model. For example, applying Legendres Rule by subtracting $1/3$ of the spherical excess from each of the three observed angles allows the use of a plane triangle as the mathematical model. The results will then be identical with those obtained by adjusting, using the spherical triangle model. Another typical example which is frequently used is to apply the appropriate $(t - T)$ and $(s - S)$ corrections to the observations and carry out the adjustment with plane trigonometry using projection co-ordinates as parameters. This must also yield identical results to those obtained using the spherical triangle.

Once the appropriate mathematical model has been decided upon, the relationships between the observations are set up in the form of equations. The type of equations is a matter of choice and convenience and may take the form of parametric equations or condition equations or a mixture of both. It must be stressed that identical results will be obtained, no matter which approach is used.

This paper will be confined to the two methods in general use, viz. the Parametric Method and the Condition or Correlate Method. *

4. The Parametric Method

The estimates of the variates are given by the Parametric Equations

$$P = p + V = AX + C \tag{10}$$

or more simply,

$$AX + T = V \tag{11}$$

where

A is the Matrix of Coefficients =
$$\begin{vmatrix} a_{11} & a_{12} & \dots & a_{1u} \\ a_{21} & a_{22} & \dots & a_{2u} \\ \dots & \dots & \dots & \dots \\ a_{n1} & a_{n2} & \dots & a_{nu} \end{vmatrix}$$
 in which $u = n - r$ 12.

X is the Matrix of Parameters =
$$\begin{vmatrix} X_1 \\ X_2 \\ \cdot \\ \cdot \\ X_u \end{vmatrix}$$
 13.

C is the Matrix of Constants =
$$\begin{vmatrix} C_1 \\ C_2 \\ \cdot \\ \cdot \\ C_n \end{vmatrix}$$
 14.

and T is the Matrix of Absolute Terms =
$$\begin{vmatrix} T_1 \\ T_2 \\ \cdot \\ \cdot \\ T_n \end{vmatrix}$$
 15.

such that $T = C - p$ 16.

* The Parametric Method is also known as the Observation or Indirect Method.

Forming the normal equations gives

$$A^T G^{-1} A X + A^T G^{-1} T = 0 \tag{17.}$$

or

$$N X + A^T G^{-1} T = 0 \text{ where } N = A^T G^{-1} A \tag{18.}$$

The solution of these normal equations is given by

$$X = -N^{-1} A^T G^{-1} T \tag{19.}$$

and the minimum M by

$$M = (A^T G^{-1} T)^T X + T^T G^{-1} T \tag{20.}$$

The matrix of the weight coefficients Q_X of the adjusted parameters X is given by the inverse matrix N^{-1} , whence

$$Q_{XX} = N^{-1} = \begin{vmatrix} Q_{X_1 X_1} & Q_{X_1 X_2} & \dots & Q_{X_1 X_u} \\ Q_{X_2 X_1} & Q_{X_2 X_2} & \dots & Q_{X_2 X_u} \\ \dots & \dots & \dots & \dots \\ Q_{X_u X_1} & Q_{X_u X_2} & \dots & Q_{X_u X_u} \end{vmatrix} \tag{21.}$$

An estimate \bar{S}^2 for the Variance Factor S^2 may be obtained from the Minimum divided by the number of redundancies

$$\bar{S}^2 = \frac{M}{r} \tag{22.}$$

The Variance Ratio $\frac{\bar{S}^2}{S^2}$ may then be tested using the F distribution test

$$\frac{\bar{S}^2}{S^2} \leq F(1 - \alpha, R_1, R_2) \tag{23.}$$

where R_1 and R_2 are the degrees of freedom used in determining \bar{S}^2 and S^2 and α is the confidence interval.

This test cannot detect the cause of failure but will indicate whether any of the following errors are present:-

- (1) Incorrect assessment of S^2 (or G).
- (2) Poor mathematical model.
- (3) Systematic errors.

Thus failure to satisfy the F distribution test should lead to a reappraisal of the observations and the mathematical model.

The matrix of weight coefficients of the estimates of the Variates Q_{PP} is given by

$$Q_{PP} = A Q_{XX} A^T \tag{24}$$

where $Q_{PP} =$
$$\begin{vmatrix} Q_{P_1 P_1} & Q_{P_1 P_2} & \dots & Q_{P_1 P_n} \\ Q_{P_2 P_1} & Q_{P_2 P_2} & \dots & Q_{P_2 P_n} \\ \dots & \dots & \dots & \dots \\ Q_{P_n P_1} & Q_{P_n P_2} & \dots & Q_{P_n P_n} \end{vmatrix} \tag{25}$$

An estimate of the variance/co-variance matrix of the adjusted parameters S_{XX}^2 is given by

$$S_{XX}^2 = S^2 Q_{XX} \tag{26}$$

and of the estimates of the variates S_{PP}^2 by

$$S_{PP}^2 = S^2 Q_{PP} \tag{27}$$

5. Example of Parametric Method

The foregoing will be used to adjust the observations for the levelling network shown in Figure 13.1

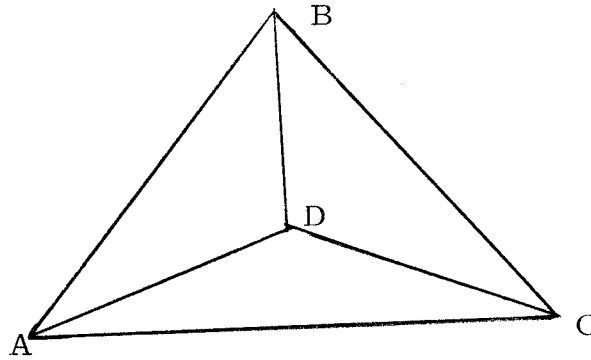

Figure 13.1

The differences of elevation and the length of levelling run between the stations are:

A to C	+ 6.16 ft.	4 miles
A to D	+12.57	2
C to D	+ 6.41	2
A to B	+ 1.09	4
B to D	+11.58	2
B to C	+ 5.07	4

The Reduced Level of Station A is 10.00 ft. and is considered error free. From past experience it is known that the type of spirit level used is capable of achieving a precision of 0.017 ft./mile of levelling.

Take the Reduced Levels of Stations B, C and D as parameters and designate these as X_B , X_C and X_D . Use Station A as datum for the adjustment.

Hence the Parametric Equations are

$$\begin{aligned}
 X_C - 6.16 &= v_1 \\
 X_D - 12.57 &= v_2 \\
 -X_C + X_D - 6.41 &= v_3 \\
 X_B - 1.09 &= v_4 \\
 -X_B + X_D - 11.58 &= v_5 \\
 -X_B + X_C - 5.07 &= v_6
 \end{aligned}$$

Expressing this in matrix notation

$$X = \begin{bmatrix} X_B \\ X_C \\ X_D \end{bmatrix} \quad 29.$$

$$p = \begin{bmatrix} + 6.16 \\ +12.57 \\ + 6.41 \\ + 1.09 \\ +11.58 \\ + 5.07 \end{bmatrix} \quad 30.$$

$$A = \begin{bmatrix} 0 & +1 & 0 \\ 0 & 0 & +1 \\ 0 & -1 & +1 \\ +1 & 0 & 0 \\ -1 & 0 & +1 \\ -1 & +1 & 0 \end{bmatrix} \quad 31.$$

The Variance Factor is taken as $S^2 = (0.017)^2$
whence

$$G = \begin{bmatrix} 4 & 0 & 0 & 0 & 0 & 0 \\ & 2 & 0 & 0 & 0 & 0 \\ & & 2 & 0 & 0 & 0 \\ & & & 4 & 0 & 0 \\ & & & & 2 & 0 \\ & & & & & 4 \end{bmatrix} \quad 32.$$

Note that where the matrix is symmetrical about the diagonal, the convention is adopted of writing only the elements of the upper triangular matrix.

$$C = \begin{vmatrix} 0 \\ 0 \\ 0 \\ 0 \\ 0 \\ 0 \end{vmatrix} \quad 33.$$

whence

$$T = \begin{vmatrix} -6.16 \\ -12.57 \\ -6.41 \\ -1.09 \\ -11.58 \\ -5.07 \end{vmatrix} \quad 34.$$

The coefficients of the Normal Equations are

$$N = \begin{vmatrix} +1 & -\frac{1}{4} & -\frac{1}{2} \\ & +1 & -\frac{1}{2} \\ & & +1\frac{1}{2} \end{vmatrix} \quad 35.$$

The Constant Terms

$$A^T G^{-1} T = \begin{vmatrix} +6.7850 \\ +0.3975 \\ -15.2800 \end{vmatrix} \quad 36.$$

and the Inverse Matrix

$$N^{-1} = \begin{vmatrix} +1.6000 & +0.8000 & +0.8000 \\ & +1.6000 & +0.8000 \\ & & +1.2000 \end{vmatrix} \quad 37.$$

thus

$$X = \begin{vmatrix} + 1.0500 \\ + 6.1600 \\ +12.5900 \end{vmatrix} \quad \text{giving} \quad \begin{array}{l} RL_B = 11.050 \\ RL_C = 16.160 \\ RL_D = 22.590 \end{array} \quad 38.$$

$$\text{The minimum } M = 0.0020 \quad 39.$$

$$\text{and} \quad \bar{S}^2 = 0.0007 \quad 40.$$

$$\text{The Variance Ratio } \frac{\bar{S}^2}{S^2} = \frac{0.0007}{0.017^2} = 2.42 \quad 41.$$

which is less than $F_{0.95, 3, \infty} (= 2.6)$ and hence the observations and adjustment are consistent with past experience at the chosen level of significance.

Carrying on, the matrix of weight coefficients of the adjusted parameters Q_{XX} is identical to the inverse matrix N^{-1} and the weight coefficients of the adjusted variates

$$Q_{PP} = \begin{vmatrix} +1.60 & +0.80 & -0.80 & +0.80 & 0.00 & +0.80 \\ & +1.20 & +0.40 & +0.80 & +0.40 & 0.00 \\ & & +1.20 & +0.00 & +0.40 & -0.80 \\ & & & +1.60 & -0.80 & -0.80 \\ & & & & +1.20 & +0.80 \\ & & & & & +1.60 \end{vmatrix} \quad 42.$$

6. The Condition or Correlate Method

In this method the estimates of the Variates are required to satisfy the r condition equations

$$BP + E = 0 \tag{43.}$$

where B is the matrix of coefficients

$$B = \begin{vmatrix} b_{11} & b_{12} & \dots & b_{1n} \\ b_{21} & b_{22} & \dots & b_{2n} \\ \dots & \dots & \dots & \dots \\ b_{r1} & b_{r2} & \dots & b_{rn} \end{vmatrix} \tag{44.}$$

and E is a matrix of constants

$$E = \begin{vmatrix} e_1 \\ e_2 \\ \cdot \\ \cdot \\ e_r \end{vmatrix} \tag{45.}$$

Substituting $P = p + v$ into the condition equations gives the Correction Equations

$$BV + D = 0 \tag{46.}$$

where

$$D = Bp + E = \begin{vmatrix} d_1 \\ d_2 \\ \cdot \\ \cdot \\ d_r \end{vmatrix} \tag{47.}$$

Using the Lagrangian Multipliers as a column vector K

$$K = \begin{pmatrix} K_1 \\ K_2 \\ \cdot \\ \cdot \\ K_r \end{pmatrix} \quad 48.$$

gives the Correlate Equations

$$V = GB^T K \quad 49.$$

Substituting these in the Correction Equations gives the Normal Equations

$$BGB^T K + D = 0 \quad 50.$$

$$\text{or} \quad NK + D = 0 \quad \text{where } N = BGB^T \quad 51.$$

$$\text{whence} \quad K = -N^{-1}D \quad 52.$$

Back substitution in the Correlate Equations gives the corrections V .
The Matrix of Weight Coefficients for the Correlates Q_{KK} is given by the inverse matrix N^{-1} .

$$Q_{KK} = N^{-1} = \begin{pmatrix} Q_{K_1 K_1} & Q_{K_1 K_2} & \dots & Q_{K_1 K_r} \\ Q_{K_2 K_1} & Q_{K_2 K_2} & \dots & Q_{K_2 K_r} \\ \dots & \dots & \dots & \dots \\ Q_{K_r K_1} & Q_{K_r K_2} & \dots & Q_{K_r K_r} \end{pmatrix} \quad 53.$$

the Weight Coefficients of the Corrections Q_{VV} by

$$Q_{VV} = \begin{pmatrix} Q_{v_1 v_1} & Q_{v_1 v_2} & \dots & Q_{v_1 v_n} \\ Q_{v_2 v_1} & Q_{v_2 v_2} & \dots & Q_{v_2 v_n} \\ \dots & \dots & \dots & \dots \\ Q_{v_n v_1} & Q_{v_n v_2} & \dots & Q_{v_n v_n} \end{pmatrix} = GB^T Q_{KK} B G^T \quad 54.$$

and the Weight Coefficients of the estimates of the Variates Q_{PP} by

$$Q_{PP} = \begin{vmatrix} Q_{P_1 P_1} & Q_{P_1 P_2} & \cdots & Q_{P_1 P_n} \\ Q_{P_2 P_1} & Q_{P_2 P_2} & \cdots & Q_{P_2 P_n} \\ \cdots & \cdots & \cdots & \cdots \\ Q_{P_n P_1} & Q_{P_n P_2} & \cdots & Q_{P_n P_n} \end{vmatrix} = G - Q_{VV} \quad 55.$$

The minimum M is given by

$$M = -D^T K \quad 56.$$

The Estimate of the Variance Factor and testing details then follow exactly as for the Parametric Method.

7. Example of Correlate Method

The previous example will now be adjusted using the Correlate Method. The conditions that will be satisfied are:

$$\begin{aligned} P_1 - P_4 - P_6 + 0.00 &= 0 \\ P_1 - P_2 + P_3 + 0.00 &= 0 \\ P_2 - P_4 - P_5 - 0.10 &= 0 \end{aligned} \quad 57.$$

or in matrix notation

$$B = \begin{vmatrix} +1 & 0 & 0 & -1 & 0 & -1 \\ +1 & -1 & +1 & 0 & 0 & 0 \\ 0 & +1 & 0 & -1 & -1 & 0 \end{vmatrix} \quad 58.$$

$$E = \begin{vmatrix} 0.00 \\ 0.00 \\ 0.00 \end{vmatrix} \quad 59.$$

$$D = \begin{vmatrix} 0.00 \\ 0.00 \\ -0.10 \end{vmatrix} \quad 60.$$

and the Variance Factor S^2 and the matrices p and G are identical to the Parametric Example.

The coefficients of the Normal Equations are

$$N = \begin{vmatrix} +12 & +4 & +4 \\ & +8 & -2 \\ & & +8 \end{vmatrix} \quad 61.$$

The inverse matrix

$$N^{-1} = \begin{vmatrix} +0.15 & -0.1 & -0.1 \\ & +0.2 & +0.1 \\ & & +0.2 \end{vmatrix} \quad 62.$$

$$\text{and } K = \begin{vmatrix} -0.0100 \\ +0.0100 \\ +0.0200 \end{vmatrix} \quad 63.$$

This gives the matrices V , P , M , \bar{S}^2 , Q_{VV} , Q_{PP} as identical to those obtained from the Parametric Method.

8. Adjustment in Phases

The adjustment may be carried out in a number of discrete sections or phases provided that the previously adjusted values and their matrix of weight coefficients are carried forward into the subsequent phases. Without realising it, most computers have been calculating in phases in all their previous adjustments. Taking the mean of the field observations for a particular variate is in fact the first phase of adjustment.

The technique of splitting an adjustment into phases is of prime importance as it allows for the continuous re-adjustment of the variates as further observations come to hand.

9. Example of Adjustment in Phases

The previous example will be adjusted by the Correlate Method taking each condition separately. The order will be to close triangle ABD, then ADC and finally BDC.

Phase 1 (Note the phase is indicated by a superscript ' on the Matrix or Variate.)

The Condition Equation is

$$P'_1 - P'_4 - P'_5 = 0 \quad 64.$$

with p' , G' and S^2 identical to the previous examples.

Then

$$B = \begin{vmatrix} 0 & +1 & 0 & -1 & -1 & 0 \end{vmatrix} \quad 65.$$

$$D' = \begin{vmatrix} -0.10 \end{vmatrix} \quad 66.$$

$$N' = \begin{vmatrix} 8 \end{vmatrix} \quad 67.$$

$$N'^{-1} = \begin{vmatrix} 0.125 \end{vmatrix} \quad 68.$$

$$K' = \begin{vmatrix} 0.0125 \end{vmatrix} \quad 69.$$

giving

$$v' = \begin{bmatrix} 0 \\ +0.0250 \\ 0 \\ -0.0500 \\ -0.0250 \\ 0 \end{bmatrix} \quad 70.$$

$$\text{and } P' = \begin{bmatrix} 6.1600 \\ 12.5950 \\ 6.4100 \\ 1.0400 \\ 11.5550 \\ 5.0700 \end{bmatrix} \quad 71.$$

The weight coefficient matrices are

$$Q'_{VV} = \begin{bmatrix} 0 & 0 & 0 & 0 & 0 & 0 \\ & +\frac{1}{2} & 0 & -1 & -\frac{1}{2} & 0 \\ & & 0 & 0 & 0 & 0 \\ & & & +2 & +1 & 0 \\ & & & & \frac{1}{2} & 0 \\ & & & & & 0 \end{bmatrix} \quad 72.$$

$$\text{and } Q'_{PP} = \begin{bmatrix} +4 & 0 & 0 & 0 & 0 & 0 \\ & +1\frac{1}{2} & 0 & +1 & +\frac{1}{2} & 0 \\ & & 2 & 0 & 0 & 0 \\ & & & +2 & -1 & 0 \\ & & & & +1\frac{1}{2} & 0 \\ & & & & & 4 \end{bmatrix} \quad 73.$$

and the Minimum $M' = 0.0012$

74.

Phase 2. In this phase the once adjusted variates are taken as "quasi" observations and hence

$$p'' = P' \quad 75.$$

$$G'' = Q'_{PP} \quad 76.$$

The Condition Equation is

$$P''_1 - P''_2 + P''_3 = 0 \quad 77.$$

Then

$$B'' = \begin{vmatrix} +1 & -1 & +1 & 0 & 0 & 0 \end{vmatrix} \quad 78.$$

$$D'' = \begin{vmatrix} -0.0250 \end{vmatrix} \quad 79.$$

$$N'' = \begin{vmatrix} +7.5 \end{vmatrix} \quad 80.$$

$$N''^{-1} = \begin{vmatrix} +0.1333 \end{vmatrix} \quad 81.$$

$$K'' = \begin{vmatrix} +0.0033 \end{vmatrix} \quad 82.$$

giving

$$V'' = \begin{vmatrix} +0.013 \\ -0.0050 \\ +0.0067 \\ -0.0033 \\ -0.0017 \\ 0 \end{vmatrix} \quad 83.$$

and

$$P'' = \begin{pmatrix} + 6.1733 \\ +12.5900 \\ + 6.4167 \\ + 1.0367 \\ +11.5533 \\ + 5.07 \end{pmatrix} \quad 84.$$

The matrices of weight coefficients are

$$Q''_{VV} = 2/15 \begin{pmatrix} +16 & -6 & +8 & -4 & -2 & 0 \\ & +2\frac{1}{4} & -3 & +1\frac{1}{2} & +\frac{3}{4} & 0 \\ & & +4 & -2 & -1 & 0 \\ & & & +1 & \frac{1}{2} & 0 \\ & & & & \frac{1}{4} & 0 \\ & & & & & 0 \end{pmatrix} \quad 85.$$

and

$$Q''_{PP} = 1/15 \begin{pmatrix} +28 & +12 & -16 & +8 & +4 & 0 \\ & +18 & +6 & +12 & +6 & 0 \\ & & +22 & +4 & +2 & 0 \\ & & & +28 & -16 & 0 \\ & & & & +22 & 0 \\ & & & & & +60 \end{pmatrix} \quad 86.$$

and the Minimum $M'' = 0.0001$ 87.

Phase 3. In this Phase the twice adjusted variates are taken as "quasi" observations and hence

$$p''' = P'' \quad 88.$$

$$G''' = Q''_{PP} \quad 89.$$

The condition is

$$P_3''' - P_5''' + P_6''' = 0 \quad 90.$$

Then

$$B''' = \begin{vmatrix} 0 & 0 & +1 & 0 & -1 & +1 \end{vmatrix} \quad 91.$$

$$D''' = \begin{vmatrix} -0.0667 \end{vmatrix} \quad 92.$$

$$N''' = \begin{vmatrix} +6.6667 \end{vmatrix} \quad 93.$$

$$N'''^{-1} = \begin{vmatrix} +0.1500 \end{vmatrix} \quad 94.$$

and $K''' = \begin{vmatrix} +0.0100 \end{vmatrix} \quad 95.$

giving

$$V''' = \begin{vmatrix} -0.0133 \\ +0.0000 \\ +0.0133 \\ +0.0133 \\ -0.0133 \\ +0.0400 \end{vmatrix} \quad 96.$$

The matrices P''' , Q_{VV}''' , Q_{PP}''' are then found to be identical with the corresponding matrices in the two previous examples.

The minimum $M''' = 0.0007 \quad 97.$

and hence the overall minimum M is given by

$$M = M' + M'' + M''' = 0.0020 \quad 98.$$

which is also identical with the previous results.

10. Example of Adjustment in Phases (Parametric Method)

The same example will be adjusted using the Parametric Method in phases. In the first phase the observations in the triangle ACD will be adjusted. In the second phase the observations to point B will be introduced.

Phase 1

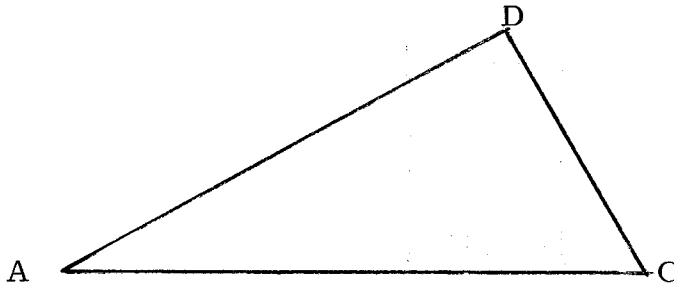

Figure 13.2

The observed quantities and the distances

A to C	+ 6.16	4 miles	p_1
A to D	+12.57	2	p_2
C to D	+ 6.41	2	p_3

give the Parametric Equations

$$\begin{aligned}
 C' - 6.16 &= v'_1 \\
 D' - 12.57 &= v'_2 \\
 -C' + D' - 6.41 &= v'_3
 \end{aligned}$$

whence

$$X' = \begin{bmatrix} C' \\ D' \end{bmatrix} = \begin{bmatrix} 6.16 \\ 12.57 \\ -6.41 \end{bmatrix} \quad 100.$$

$$p' = \begin{vmatrix} + 6.16 \\ +12.57 \\ + 6.41 \end{vmatrix} \quad 101.$$

$$A' = \begin{vmatrix} +1 & 0 \\ 0 & +1 \\ -1 & +1 \end{vmatrix} \quad 102.$$

$$\text{and } G' = \begin{vmatrix} 4 & 0 & 0 \\ & 2 & 0 \\ & & 2 \end{vmatrix} \quad 103.$$

$$\text{with } S^2 = (0.017)^2 \quad 104.$$

$$\text{Now } C' = \begin{vmatrix} 0.0 \\ 0.0 \\ 0.0 \end{vmatrix} \quad 105.$$

$$\text{thus } T' = \begin{vmatrix} - 6.16 \\ -12.57 \\ - 6.41 \end{vmatrix} \quad 106.$$

which gives the coefficients of the Normal Equation as

$$N' = \begin{vmatrix} \frac{3}{4} & - & \frac{1}{2} \\ & & 1 \end{vmatrix} \quad 107.$$

with constant terms

$$A'^T G'^{-1} T' = \begin{vmatrix} +1.6650 \\ -9.4900 \end{vmatrix} \quad 108.$$

The inverse matrix

$$N'^{-1} = \begin{vmatrix} 2 & 1 \\ & 1.5 \end{vmatrix} \quad 109.$$

yields the first adjusted parameters

$$X' = \begin{vmatrix} + 6.1600 \\ +12.5700 \end{vmatrix} \quad 110.$$

$$\text{the minimum } M' = 0.0 \quad 111.$$

$$\text{and the once adjusted variates } P' = \begin{vmatrix} + 6.16 \\ +12.57 \\ + 6.41 \end{vmatrix} \quad 112.$$

It should be noted that these results are simply fortuitous and were caused by the fact that the observations in the triangle "closed". In general, this would not be the case and hence there would be some corrections in this phase.

The matrix of weight coefficients of the once adjusted parameters is

$$Q'_{XX} = \begin{vmatrix} 2 & 1 \\ & 1.5 \end{vmatrix} \quad 113.$$

and of the once adjusted variates

$$Q'_{PP} = \begin{vmatrix} +2 & +1 & -1 \\ & +1.5 & -0.5 \\ & & +1.5 \end{vmatrix} \quad 114.$$

Phase 2. For the second phase, the first adjusted parameters are regarded as "quasi" observations and taken into the adjustment with their weight coefficients together with the new observations.

Thus the observations for this phase are

$$\begin{aligned}
 B'' - 1.09 &= v_4 \\
 -B'' + D'' - 11.58 &= v_5 \\
 -B'' + C'' - 5.07 &= v_6 \\
 \text{and } C'' - C' &= v_7 = C'' - 6.1600 \\
 D'' - D' &= v_8 = D'' - 12.5700
 \end{aligned}
 \tag{115}$$

In matrix form,

$$p'' = \begin{vmatrix} + 1.09 \\ +11.58 \\ + 5.07 \\ + 6.1600 \\ +12.5700 \end{vmatrix}
 \tag{116}$$

with

$$G'' = \begin{vmatrix} 4 & 0 & 0 & 0 & 0 \\ & 2 & 0 & 0 & 0 \\ & & 4 & 0 & 0 \\ & & & 2 & 1 \\ & & & & 1.5 \end{vmatrix}
 \tag{117}$$

$$\text{and } A'' = \begin{vmatrix} +1 & 0 & 0 \\ -1 & 0 & +1 \\ -1 & +1 & 0 \\ 0 & +1 & 0 \\ 0 & 0 & +1 \end{vmatrix}
 \tag{118}$$

Inverting the matrix of weight coefficients gives

$$G''^{-1} = \begin{vmatrix} 1/4 & 0 & 0 & 0 & 0 \\ & 1/2 & 0 & 0 & 0 \\ & & 1/4 & 0 & 0 \\ & & & 3/4 & -1/2 \\ & & & & 1 \end{vmatrix} \quad 119.$$

and hence the coefficients of the Normal Equations as

$$N'' = \begin{vmatrix} +1 & -1/4 & -1/2 \\ & +1 & -1/2 \\ & & +1.5 \end{vmatrix} \quad 120.$$

$$\text{with } A''^T G''^{-1} T'' = \begin{vmatrix} + & 6.7850 \\ + & 0.3975 \\ - & 15.2800 \end{vmatrix} \quad 121.$$

It will be seen that both the above matrices are identical with the corresponding matrices in the single phase adjustment and hence must yield an identical solution.

11. Adjustment of an Example with Dissimilar Quantities

In order to stress that the same approach may be used when dissimilar quantities are to be adjusted, a simple example of the adjustment of a triangle with measured angles and sides is included.

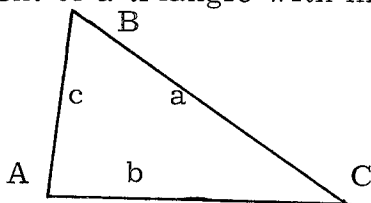

Figure 13.3

There are 3 redundant observations and hence 3 conditions. Taking the 3 conditions in the form of one angular close and 2 side conditions gives the Condition Equations as

$$P_A + P_B + P_C - (180 + \Sigma) = 0$$

$$\frac{P_a}{\sin P_A} = \frac{P_b}{\sin P_B}$$

122.

and $\frac{P_a}{\sin P_A} = \frac{P_c}{\sin P_C}$

It should be noted that the arc-sine transformation has been applied to the observed distances before entering the adjustment.

The correction equations then follow as

$$\begin{aligned} v_A + v_B + v_C + d_1 &= 0 \\ \delta_a v_a - \delta_b v_b - \delta_A v_A + \delta_B v_B + d_2 &= 0 \\ \delta_a v_a - \delta_c v_c - \delta_A v_A + \delta_C v_C + d_3 &= 0 \end{aligned}$$

123.

Where δ is the common difference of logarithms for an increase of 1 unit (the same unit as the corrections) in the log. side and log. sine angle respectively expressed normally in the 6th decimal place of logarithms.

If the numerical example of Clark, "Plane and Geodetic Surveying", Volume II, 5th edition, page 390, is taken then

$$p = \begin{vmatrix} 63^\circ & 19' & 25''70 \\ 75^\circ & 13' & 21''60 \\ 41^\circ & 27' & 12''90 \\ 94 & 277.10 \text{ ft.} \\ 102 & 017.34 \\ 69 & 847.62 \end{vmatrix}$$

124.

$$E = \begin{vmatrix} -180^{\circ} & 00 & 01.50 \\ & 0 & \\ & & 0 \end{vmatrix} \quad 125.$$

and taking as the Variance Factor

$$S^2 = \left(\frac{1}{0.674} \right)^2 = 2.1820 \quad 126.$$

to reduce Clark's Probable Errors to Standard Deviations then

$$G = \begin{vmatrix} 0.25 & 0 & 0 & 0 & 0 & 0 \\ & 0.16 & 0 & 0 & 0 & 0 \\ & & 0.36 & 0 & 0 & 0 \\ & & & 0.25 & 0 & 0 \\ & & & & 0.16 & 0 \\ & & & & & 0.09 \end{vmatrix} \quad 127.$$

The matrix of coefficients is then

$$B = \begin{vmatrix} +1 & +1 & +1 & 0 & 0 & 0 \\ -1.06 & +0.56 & 0 & +4.6 & -4.26 & 0 \\ -1.06 & 0 & +2.38 & +4.6 & 0 & -6.2 \end{vmatrix} \quad 128.$$

$$\text{and } D = \begin{vmatrix} -1.30 \\ +2.30 \\ -2.10 \end{vmatrix} \quad 129.$$

which lead to the Normal Equations

$$N = \begin{vmatrix} +0.7700 & -0.1754 & + 0.5918 \\ & +8.5247 & + 5.5709 \\ & & +11.0697 \end{vmatrix} \quad 130.$$

the inverse matrix

$$N^{-1} = \begin{vmatrix} +1.4301 & +0.1182 & -0.1360 \\ & +0.1846 & -0.0992 \\ & & +0.1475 \end{vmatrix} \quad 131.$$

The Correlate Values are

$$K = \begin{vmatrix} +1.3017 \\ -0.4792 \\ +0.3611 \end{vmatrix} \quad 132.$$

and the adjusted variates

$$P = \begin{vmatrix} 63^{\circ} & 19' & 26''.06 \\ 75 & 13 & 21.76 \\ 41 & 27 & 13.68 \\ 94 & 276.96 \text{ ft.} & \\ 102 & 017.67 & \\ 67 & 847.42 & \end{vmatrix} \quad 133.$$

The minimum is

$$M = 3.5527 \quad 134.$$

$$\text{and } \bar{S}^2 = 1.1842 \quad 135.$$

giving a Variance Ratio of

$$\frac{S^2}{\bar{S}^2} = 1.84 \quad 136.$$

The F distribution test using $F_{0.975, R_1, R_2}$ to give the 95% confidence level for a lower tail value gives

$$F_{0.975, \infty, 3} = 14 \quad 137.$$

which exceeds the variance ratio. The adjustment is then consistent.

Finally, the matrix of weight coefficients of adjusted variates is

$$Q_{PP} = \begin{vmatrix} +0.1489 & -0.0647 & -0.1456 & -0.1011 & -0.0647 & -0.0364 \\ & +0.1186 & -0.0932 & -0.0647 & -0.0414 & -0.0233 \\ & & +0.1503 & -0.1456 & -0.0932 & -0.0524 \\ & & & +0.1489 & -0.0647 & -0.0364 \\ & & & & +0.1186 & -0.0233 \\ & & & & & +0.0769 \end{vmatrix} \quad 138.$$

12. Significance of the Weight Coefficients of Adjusted Values

Although not directly within the scope of this paper, it is desirable to include some mention of the concluding steps in the sequence of calculation. By the application of the General Law of Propagation of Variances, the variance/covariance matrix of the adjusted co-ordinates (or other parameter) may be deduced from the matrix of Weight Coefficients of the adjusted variates.

The components of the Standard Error Ellipses for the parameters may then be calculated and the ellipses plotted. A visual check will then indicate any inherent weaknesses in the configuration and the appropriate steps taken to remedy the defect.

It should be noted that, since the observations give only the scale of the ellipses, provided that the weight coefficients of the observations may be estimated, the ellipses may be deduced prior to observation. Accordingly, the relative merits of various configurations may be investigated at the reconnaissance stage.

A further application of the General Law gives the Relative Standard Ellipses for individual lines which may require a more detailed examination.

13. Conclusion

The use of matrix notation demonstrates the feasibility of generalized programmes for electronic computers to solve all Least

Square adjustments. The "on line" storage capacity of the computer imposes the only limitation on the size of the problems that can be handled. However, the manipulations of matrix multiplication and addition do not require full "on line" storage and so the main limitation is therefore the storage required for the matrix inversion.

The significance of the adjustment in phases is that the adjustment is divided into a number of sections in each of which the size of the matrix to be inverted is reduced. A careful selection of the points at which the adjustment is divided will allow large adjustments to be carried out using a small computer.

For engineering projects or large control surveys where provisional values are required, the technique of phase adjustment may be used to give continuous adjustment. By this approach, as later observations come to hand they may be conveniently included in the adjustment.

Finally, the importance is seen of the matrix of weight coefficients when adjusting in phases or adjusting derived quantities.

Bibliography.

- (1) P. Richardus. Project Surveying. North Holland, Amsterdam, 1966.
- (2) J.M. Tienstra. Theory of the Adjustment of Normally Distributed Observations. Argus, Amsterdam, 1965.
- (3) A.B. Sunter. Statistical Properties of Least Square Estimates. Canadian Surveyor, XX, No. 1, March 1966.
- (4) E.H. Thompson. The Theory of the Method of Least Squares. The Photogrammetric Record, IV, No. 19, April 1962.

PAPER NO. 14

THE EFFECT OF CORRELATED MEASUREMENTS ON
ERROR PROPAGATION IN A TRIANGULATED STRIP

by

S.G. Bervoets.

Abstract: Only elementary aspects of the concept co-variance are required to see how systematic errors lead to correlation in a series of measurements. This correlation may be included in a least squares adjustment by the introduction of the matrix of weight coefficients. The results obtained in this manner are expected to be superior to those obtained by a least squares adjustment in which only relative weights are considered.

A simple example of distance measurement is used to demonstrate this, but it is also shown that the improvement depends on the circumstances.

Finally, a theoretical assessment of the sources of error in analytical aerotriangulation is given with a view to finding the conditions which make the inclusion of correlation important.

1. Introduction

The measurements in aerotriangulation are "correlated", hence their adjustment should not merely be based on the minimum value of Σv^2 (Least Squares), or even the minimum value of Σpv^2 , a more discriminating method causing the sum of weighted squares to be a minimum. Instead

so-called combined weights are introduced, which include the effect of correlation and lead to the insertion of the second term in

$(p_{11} v_1^2 + 2p_{12} v_1 v_2 + p_{22} v_2^2)$, the minimum value of which serves as the basis for adjustment in a case where two correlated measurements are involved.

Much of this paper is devoted to the more elementary aspects of correlation, its interpretation and how it arises in measurements whose errors are functions of other sources of error which the measurements have in common. It follows that systematic errors, which are themselves functions of the measurements, cause correlation through the uncertainty in the parameters. The case of distance measurement with a band of incorrect length is quoted, giving rise to the so-called matrix of weight coefficients in equation 17.

Now on the one hand there are the actual correlation coefficients resulting from the actual pattern of errors, while on the other hand there are the assumed coefficients used in the adjustment. If for whatever reason the assumed coefficients differ markedly from the actual weight coefficients the result of the adjustment will probably be inferior. This by the way includes the omission of correlation coefficients from an adjustment based on $\Sigma p v^2$ a minimum in cases where the errors are subject to common sources of error.

To test this proposition a simple theoretical case of linear measurements of two distances involving one condition was simulated on an electronic computer. Both measurements were perturbed by a systematic and a random error and subsequently adjusted, first rigorously by assuming the same weight coefficients as actually used in the generation of errors, and then approximately assuming no correlation at all but only different weights. This process was repeated 50 times and then the standard deviation of the residuals (i. e. remaining after adjustment) was calculated both for the rigorous and approximate adjustment in various cases.

As expected the approximate adjustment (no correlation) gave the larger deviation, but not in all circumstances. If no systematic errors were generated the omission of correlation naturally had no effect because it is caused by the systematic errors in the first place. If, however, the

real systematic errors dominate the random errors, the omission is a serious matter. There are many gradations between the extremes shown in Table I.

In paragraph 7 an attempt is made to enumerate the sources of errors in analytical triangulation in Photogrammetry resulting in equations 25. The main objective of the research project to which this paper refers is to find out to what extent each source contributes and whether it requires rigorous adjustment or not. If it turns out that some errors, though strongly correlated by nature, do not significantly affect the adjustment because of the geometrical configuration of the measurements they may well be left alone. But other errors may require careful assessment so as to produce the proper weight coefficients for getting the best results.

2. Correlation and Least Squares

The concept correlation in connection with adjustments is a statistical one and should not be confused with algebraical dependency. In formulae 1. y_1 and y_2 are functions of the independent variables x_1 and x_2 i. e. for each set of values for x_i the corresponding values for y_i are unequivocally determined.

$$\begin{aligned} y_1 &= a_{11}x_1 + a_{12}x_2 \\ y_2 &= a_{21}x_1 + a_{22}x_2 \end{aligned} \quad 1.$$

If, however, x_1 and x_2 are chance variables one does not quite know what values they will assume, except that something may be known about their frequency distributions. By repeatedly taking a sample i. e. a set of values for x_1 and x_2 from their respective frequency distributions, a distribution may also be obtained for y_1 as well as y_2 . Because y_1 and y_2 depend on the same set of values each time a sample of x_1 and x_2 is taken, the two distributions of y_1 and y_2 will have a mutual relationship. It is this mutual relationship which is called correlation.

Suppose x_1 and x_2 are both normally distributed with the same degree of scatter (as expressed by their standard deviation σ), but otherwise the distributions have nothing in common. In somewhat simplified phraseology it means that the chances (probability) of having a particular value x_1 are proportional to $e^{-x_1^2/2\sigma^2}$, likewise the probability of obtaining a particular value x_2 is proportional to $e^{-x_2^2/2\sigma^2}$. Thus the probability of obtaining a particular value x_1 and (at the same time) a particular value x_2 is proportional to the product of the individual probabilities i. e. $e^{-(x_1^2 + x_2^2)/2\sigma^2}$.

If x_1 and x_2 are plotted on rectangular axes, then the pairs of values having the same probability density (i. e. the same chances of occurring simultaneously) are those for which the above function is constant, i. e. $(x_1^2 + x_2^2)$ is constant. Thus the loci of points having the same probability density form a system of concentric circles with the equation

$$x_1^2 + x_2^2 = r^2 \quad 2.$$

Because of the negative exponent in the probability density function it is clear that all combinations of x_1 and x_2 giving a larger radius lead to a smaller probability density. In other words, the smaller the sum of the squares x_1^2 and x_2^2 the greater is the likelihood of those particular values x_1 and x_2 occurring simultaneously. (Figure 14.1)

This of course is the basis of a least squares adjustment in which x_1 and x_2 represent corrections assumed to be normally distributed.

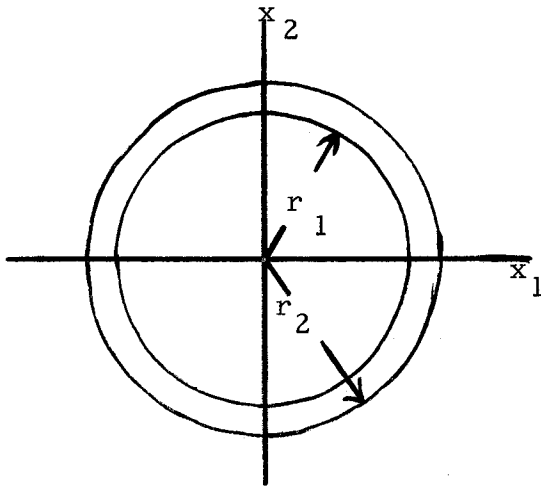

Figure 14.1

Circles of constant probability density P because $r_1 < r_2$, one finds $P_1 > P_2$.

Weights are introduced if x_1 and x_2 have different standard deviations σ_1 and σ_2 . In that case the exponent of the probability density function is

$$-\frac{1}{2} \left(x_1^2 / \sigma_1^2 + x_2^2 / \sigma_2^2 \right)$$

Combinations of x_1 and x_2 giving a constant probability density then form ellipses whose semi-axes are proportional to σ_1 and σ_2 along the co-ordinate axes. The weights are taken inversely proportional to the squares of the standard deviations, and are therefore defined by (p standing for poid = weight):

$$p_1 = \sigma^2 / \sigma_1^2 \quad \text{and} \quad p_2 = \sigma^2 / \sigma_2^2 \quad 3.$$

Upon substitution in the exponent which is required to be a minimum one obtains

$$p_1 x_1^2 + p_2 x_2^2 \quad \text{a minimum} \quad 4.$$

A different concept arises if y_1 and y_2 of 1. occur in an adjustment problem and the most probable solution is to be found. To see what combinations of y_1 and y_2 are most likely to occur simultaneously, x_1 and x_2 may be expressed in terms of y_1 and y_2 by the inverse of 1. and substituted in the equation of a circle 2. For the sake of brevity vector and matrix notation will be used here. For those not familiar with this kind of notation it will be sufficient to note the conclusion of this substitution.

Thus let $\underline{x} = \begin{bmatrix} x_1 & x_2 \end{bmatrix}'$, then 1. may be written in the form

$$\underline{y} = \underline{Ax}, \text{ whence } \underline{x} = \underline{A}^{-1} \underline{y}.$$

The equation 2. of the circle reads $\underline{x}' \underline{x} = r^2$.

$$\text{Substitution gives } \underline{y}' (\underline{AA}')^{-1} \underline{y} = r^2.$$

$$\text{or } \underline{y}' \underline{P} \underline{y} = r^2 \quad 5.$$

\underline{P} is a symmetric matrix and 5. is the equation of an ellipse (or a set of concentric ellipses for varying r) giving combinations of y_1 and y_2 having the same probability density. The algebraic expression of 5. is

$$p_{11}y_1^2 + 2p_{12}y_1y_2 + p_{22}y_2^2 = r^2 \quad 6.$$

in which p_{11} and p_{22} are similar in nature to the weights p_1 and p_2 in 3.

It is known from co-ordinate geometry that the coefficient p_{12} in 6. determines the attitude of the ellipses with respect to the co-ordinate axes. The fact that the ellipses are inclined with respect to the axes has a bearing on the probability density of y_1 for constant values of y_2 . As

evident from Figure 14.2 the point of the highest probability density of y_1 for a given constant value of y_2 is the intersection of the corresponding line $y_2 = k$ with the conjugate diameter of the ellipse tangential to $y_2 = k$. This phenomenon is called correlation and it tells what value of y_1 one is most likely to find in conjunction with y_2 etc.

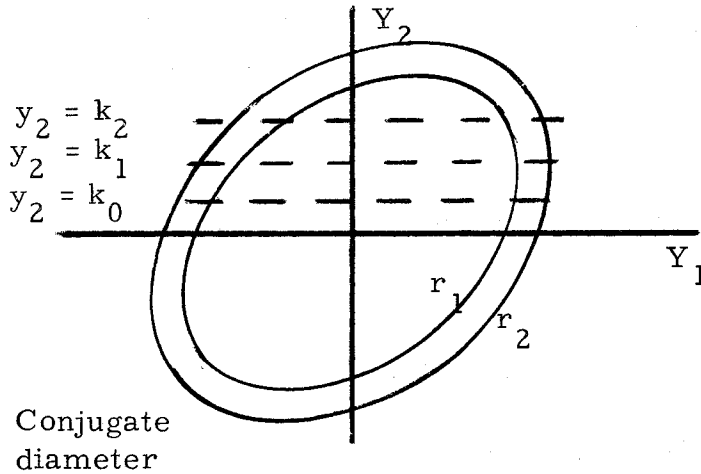

Figure 14.2

$$r_1 < r_2 \quad \text{thus}$$

$$P_1 > P_2$$

It is not within the scope of this article to show in detail just how correlation and the coefficient p_{12} are related to each other. Let it suffice to say that if y_1 and y_2 represent corrections in a least squares adjustment the instruction for adjustment will be:

$$p_{11}y_1^2 + 2p_{12}y_1y_2 + p_{22}y_2^2 \text{ a minimum.}$$

If $p_{12} = 0$ we have the classical case of no correlation and different weights as in equation 4. of this paragraph.

3. Weight Coefficients and Weights

Rather than giving the full derivation of the meaning of p_{12} the purpose of this paper is to show how the matrix \underline{P} of 5. including the coefficients p_{11} , p_{12} and p_{22} can be obtained in various cases and how

these cases arise. Once again, for brevity's sake, matrix notation is employed, but at appropriate places reference will be made to ordinary algebraic notation so as to enable the reader not fully familiar with matrix notation to follow the argument.

Weight coefficients are defined as quantities proportional to the square of the standard deviations (as opposed to weights which are inversely proportional).

$$\text{Thus } \sigma_1^2 = (x_1 x_1) \sigma^2 \text{ and } \sigma_2^2 = (x_2 x_2) \sigma^2 \quad 7.$$

Here $(x_i x_i)$ is a symbolic notation for the weight coefficient of x_i , similar to that used by Tienstra but more adaptable to matrix notation. The common factor σ^2 is called the variance factor in statistics. If $\sigma_1^2 = \sigma_2^2 = \sigma^2$ one finds $(x_1 x_1) = (x_2 x_2) = 1$ unity

Now consider the product of a vector times its transpose.

$$\text{In the usual notation: } \underline{x} \underline{x}' = \begin{vmatrix} x_1 \\ x_2 \end{vmatrix} \begin{vmatrix} x_1 & x_2 \end{vmatrix} = \begin{vmatrix} x_1 x_1 & x_1 x_2 \\ x_2 x_1 & x_2 x_2 \end{vmatrix}$$

To define weight coefficients in matrix form let $(\underline{x} \underline{x}')$, (i.e. with brackets round the product), be the symbolic notation of a matrix whose elements are formed in a similar fashion and denoted by $(x_i x_j)$. The weight coefficients are then obtained by putting $(x_i x_j) = \delta_{ij}^j$.

$$\delta_{ij}^i \text{ (Kronecker Delta) } = 1 \text{ if } i = j \text{ or } 0 \text{ if } i \neq j$$

$$\text{In this manner } (\underline{x} \underline{x}') = \begin{vmatrix} 1 & 0 \\ 0 & 1 \end{vmatrix} = \underline{I} \text{ (unit matrix).} \quad 8.$$

The weight coefficients ($y_i y_j$) may now be found as follows.

From equations 1.: $\underline{y} = \underline{A} \underline{x}$, whence $\underline{y}' = \underline{x}' \underline{A}'$ and $\underline{y} \underline{y}' = \underline{A} \underline{x} \underline{x}' \underline{A}'$.

Using the same symbolic notation as above

$$(\underline{y} \underline{y}') = \underline{A} (\underline{x} \underline{x}') \underline{A}' = \underline{A} \underline{I} \underline{A}' = \underline{A} \underline{A}'$$

Let \underline{Q} be a more conventional name for the matrix of weight coefficients, i. e.

$$\underline{Q} = (\underline{y} \underline{y}') = \begin{vmatrix} (y_1 y_1) & (y_1 y_2) \\ (y_2 y_1) & (y_2 y_2) \end{vmatrix} = \underline{A} \underline{A}' \quad 9.$$

Upon evaluation one finds:

$$\underline{Q} = \begin{vmatrix} (y_1 y_1) & (y_1 y_2) \\ (y_2 y_1) & (y_2 y_2) \end{vmatrix} = \begin{vmatrix} (a_{11}^2 + a_{12}^2) & (a_{11} a_{21} + a_{12} a_{22}) \\ (a_{11} a_{21} + a_{12} a_{22}) & (a_{21}^2 + a_{22}^2) \end{vmatrix}$$

After examining equations 1. again it is obvious that the standard deviations of y_1 and y_2 are

$$\sigma_{y_1}^2 = (a_{11}^2 + a_{12}^2) \sigma^2 \text{ and } \sigma_{y_2}^2 = (a_{21}^2 + a_{22}^2) \sigma^2$$

respectively.

The quantities on the diagonal of the matrix $\underline{A} \underline{A}'$ may indeed be regarded as the weight coefficients of y_1 and y_2 with again σ^2 as the variance factor. The quantity $(a_{11} a_{21} + a_{12} a_{22}) \sigma^2$ is defined in statistics as co-variance, denoted by $\sigma_{y_1 y_2}$ and is a measure of correlation (1).

The matrix \underline{P} of equation 5. was the inverse of $\underline{A} \underline{A}'$, and thus, having defined

$$\underline{Q} = \underline{A} \underline{A}' \quad \text{see 9.}$$

one obtains

$$\underline{P} = \underline{Q}^{-1} \quad 10.$$

The problem of determining weights for the purpose of a least square adjustment, therefore, appears rather as a problem of determining weight coefficients because once the latter are known the former are found by calculation as a matrix inversion. Let $q_{ij} = (y_i y_j)$ be the weight coefficients (given) and p_{ij} the weights (to be found), then according to 10.:

$$\underline{Q} \underline{P} = \underline{I} \text{ or } \begin{vmatrix} q_{11} & q_{12} \\ q_{21} & q_{22} \end{vmatrix} \begin{vmatrix} p_{11} & p_{12} \\ p_{21} & p_{22} \end{vmatrix} = \begin{vmatrix} 1 & 0 \\ 0 & 1 \end{vmatrix}$$

or

$$\begin{aligned} q_{11}p_{11} + q_{12}p_{21} &= 1 & \text{and} & & q_{11}p_{12} + q_{12}p_{22} &= 0 \\ q_{21}p_{11} + q_{22}p_{21} &= 0 & & & q_{21}p_{12} + q_{22}p_{22} &= 1 \end{aligned}$$

The determination of p_{ij} requires the solution of two sets of simultaneous equations.

4. The Mathematics of Adjustment

Just how the weight coefficients, i.e. the elements q_{ij} of the matrix \underline{Q} are formed in the first place will not be discussed in detail, as a general theory would again be quite outside the scope of this paper. Only one instance will be quoted here, whereby the formation of the matrix of weight coefficients is a mathematical expediency for the purpose of adjustment.

Let the adjustment problem be formulated in the following manner, combining observation equations with condition equations:

$$b_{11}z_1 + b_{12}z_2 = k_1 + a_{11}x_1 + a_{12}x_2 + a_{13}x_3$$

$$b_{21}z_1 + b_{22}z_2 = k_2 + a_{21}x_1 + a_{22}x_2 + a_{23}x_3$$

where z_1 and z_2 are unknown parameters and x_1, x_2, x_3 corrections to observations assumed to be of the same precision and correlation free, therefore having unit weight. The adjustment calls for $x_1^2 + x_2^2 + x_3^2$ to be minimum, in matrix notation $\underline{x}'\underline{x}$ a minimum. The problem fits the concept of paragraph 3 admirably. The polynomials in x_i on the right hand side may be replaced by:

$$\begin{aligned} y_1 &= a_{11}x_1 + a_{12}x_2 + a_{13}x_3 \quad \text{or} \quad \underline{y} = \underline{A} \underline{x} \\ y_2 &= a_{21}x_1 + a_{22}x_2 + a_{23}x_3 \end{aligned} \quad 11.$$

This reduces the problem to

$$\begin{aligned} b_{11}Z_1 + b_{12}Z_2 &= k_1 + y_1 \quad \text{or} \quad \underline{B} \underline{z} = \underline{k} + \underline{y} \\ b_{21}z_1 + b_{22}z_2 &= k_2 + y_2 \end{aligned} \quad 12.$$

The matrix of weight coefficients of x_i (of equal weight) is $(\underline{x} \ \underline{x}') = I$ and that of y_i , with the aid of 11. $(\underline{y} \ \underline{y}') = \underline{A}(\underline{x} \ \underline{x}')\underline{A}' = \underline{A}\underline{A}' = \underline{Q}$.

The condition $\underline{x}'\underline{x}$ a minimum turns into $\underline{y}'(\underline{A} \ \underline{A}')^{-1}\underline{y}$ a minimum, i. e. $\underline{y}'\underline{P}\underline{y}$ a minimum where $\underline{P} = \underline{Q}^{-1}$.

Equations 12., therefore, can be treated as an ordinary set of observation equations in which the quasi-corrections \underline{k} must be adjusted so as to make $\underline{y}'\underline{P}\underline{y} = p_{11}y_1^2 + 2p_{12}y_1y_2 + p_{22}y_2^2$ a minimum.

Elsewhere (2), (3) it is shown that the normal equations assume the form

$$\underline{B}^T \underline{P} \underline{B} \underline{z} = \underline{B}^T \underline{P} \underline{k} \quad 13.$$

5. Systematic Errors and Correlation

One of the objectives of the introductory paragraphs to this paper is to show that systematic errors may lead to strong correlation. As a typical and at the same time simple example consider distance measurement with a Surveyor's band of incorrect length. The errors in two distances measured are made up as follows:-

$$dl_1 = l_1 ds + dr_1 \quad 14.$$

$$dl_2 = l_2 ds + dr_2$$

In these ds = systematic error per unit of length and dr_1 and dr_2 the total random errors due to the measuring technique in the two distances respectively. The variances, i. e. the squares of the standard deviations, must somehow be estimated and lead to the weight coefficients in

$$\sigma_s^2 = (ss) \sigma^2 \quad \sigma_{r_1}^2 = (r_1 r_1) \sigma^2 \quad 15.$$

$$\text{and } \sigma_{r_2}^2 = (r_2 r_2) \sigma^2$$

in which the actual values of the weight coefficients are finally determined by a suitable choice of σ^2 . Using matrix notation in connection with 14, one finds for the weight coefficients of l_1 , according to paragraph 3.

$$\begin{vmatrix} (l_1 l_1) & (l_1 l_2) \\ (l_2 l_1) & (l_2 l_2) \end{vmatrix} = \begin{vmatrix} l_1 & 1 & 0 \\ l_2 & 0 & 1 \end{vmatrix} \begin{vmatrix} (ss) & 0 & 0 \\ 0 & (r_1 r_1) & 0 \\ 0 & 0 & (r_2 r_2) \end{vmatrix} \begin{vmatrix} l_1 & l_2 \\ 1 & 0 \\ 0 & 1 \end{vmatrix}$$

$$\text{or } \underline{Q} = \begin{vmatrix} l_1^2 (ss) + (r_1 r_1) & l_1 l_2 (ss) \\ l_1 l_2 (ss) & l_2^2 (ss) + (r_2 r_2) \end{vmatrix} \quad 16.$$

It is known that the square of the random error in distance measurement with a band is proportional to the length measured. Thus if $(rr) \sigma^2$ represents the variance of the random error per unit length one may put in 15. : $\sigma_{r_i}^2 = l_i (rr) \sigma^2$ which after substitution in the derivation of 16. gives

$$\underline{Q} = \begin{vmatrix} l_1^2 (ss) + l_1 (rr) & l_1 l_2 (ss) \\ l_1 l_2 (ss) & l_2^2 (ss) + l_2 (rr) \end{vmatrix} \quad 17.$$

The non-diagonal elements of \underline{Q} are proportional to the co-variances and it is evident, therefore, that in this case the systematic error (estimated by σ_s^2) introduces correlation between the measured distances l_1 and l_2 .

The principal proposition now, as formulated by Tienstra (2) is that in any adjustment problem in which l_1 and l_2 occur the weight coefficients proportional to the co-variances must be taken into account, and that if they are not the result of the adjustment will be inferior.

It must be pointed out that this is a statistical statement, in that a single pair of measurements followed by an adjustment is considered to be but one sample of a whole series of such pairs of measurements followed by their adjustments. The quality of this series of adjustments (and consequently of any one of them) is therefore expressed in terms of the standard deviations of the remaining (true residual) errors after adjustment. It can be shown theoretically that the standard deviation of the adjusted measurements will be smaller when correlation is taken into account compared with adjustments where correlation is omitted.

It is of course possible that the improvement turns out to be insignificant and each case will probably have to be judged on its own merits.

6. Simulation on a Computer

In an attempt to produce convincing evidence with regard to the statements in paragraph 5, the following problem was simulated on a 7044 I.B.M. electronic computer.

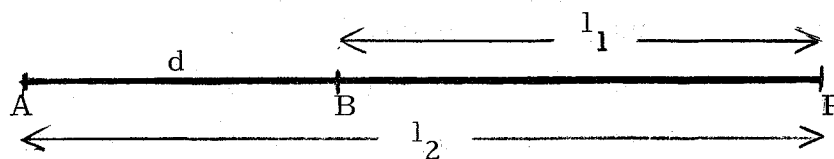

Figure 14.3 Determination of P relative to A and B at a known distance d by measuring l_1 and l_2 .

The input to the computer consisted of "true" distances l_1 and l_2 , and the assumed standard deviations per unit length of the systematic and random error respectively. Using the latter two and with the aid of random deviates from a normal distribution with mean = 0 and standard deviation = 1 the same systematic "error" per unit length was produced for both measurements, and a random "error" for each. Each set out of fifty so generated was adjusted twice, first by including the full matrix of weight coefficients and secondly by omitting the correlation coefficient. True "residuals" in the position of P could then be calculated by taking (the error in l_2) - (the true correction), and false residuals by subtracting the false correction. True and false here are used in the sense of residuals obtained with the full matrix of weight coefficients and the

incomplete matrix respectively. Finally the standard deviation of each series of residuals was calculated.

Case	Systematic st. devn. / unit length	Random (st. devn.) ² / unit length	Standard Deviation of 50 residuals	
			True	False
1	0.004	0.001	2.3	4.8
2	0.001	0.004	1.8	1.8
3	0.004	0	0	4.8
4	0	0.004	1.4	1.4

TABLE I. True and False Residuals
for $l_1 = 1000$ and $l_2 = 2000$

As expected in case 4 the omission of correlation made no difference because the correlation was non-existent in the first place with no systematic error being present.

If anyone still doubts the soundness of Tienstra's theories he should at least be convinced by the outcome of case 3 that they are capable of dealing with systematic errors !! For if no random errors are present, the misclosure in the condition equation of Figure 14.3 can only be due to the systematic error and of course the arrangement of data in this case allows the systematic error to be fully determined so that there should not be any residual after adjustment.

Cases 1 and 2 are the really interesting ones in that the omission of the correlation only produces a significant deterioration in the result if the systematic error outweighs the random error (case 1), while in the opposite case there is no difference.

It should also be pointed out that the significance of the omission of correlation also depends on the geometry of the data. e. g. if $d = 0$ in Figure 14.3 the condition equation would become

$$(l_1 + v_1) - (l_2 + v_2) = 0$$

The ratio of the corrections would be that of the elements of the vector

$$\begin{vmatrix} q_{11} & q_{12} \\ q_{12} & q_{22} \end{vmatrix} \begin{vmatrix} 1 \\ -1 \end{vmatrix} \quad \text{which because } l_1 = l_2$$

turns into $v_1/v_2 = (q_{11} - q_{12}) / (q_{12} - q_{11})$. The corrections v_1 and v_2 would always be equal and opposite whether or not $q_{12} = 0$, and thus omission or inclusion of the correlation just does not make any difference.

In the next paragraphs the sources of error in stereocomparator measurements are considered and an indication is given of how their influence can be traced in the analytical triangulation of a single strip.

7. Errors in Stereocomparator Measurements

Before tracing the errors and setting up the appropriate matrix of weight coefficients for the purpose of adjustment it will be shown how spatial co-ordinates may be calculated from stereocomparator measurements. Let \underline{x} and \underline{y} be the vectors of the observed fiducial co-ordinates on the stereocomparator, \underline{L} and \underline{R} the rotation matrices and \underline{b} the assumed base. Parallax is defined by the following equation:-

$$\lambda \underline{l} - \rho \underline{r} - \underline{b} = \underline{p}$$

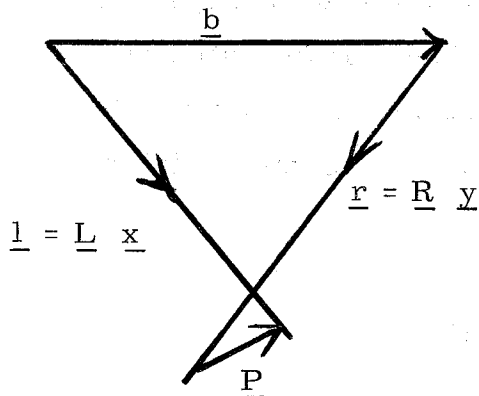

Figure 14.4

Definition of parallax.

Spatial co-ordinates are only defined if the parallax can be eliminated ($\underline{p} = \underline{0}$), thus the condition becomes

$$\lambda \underline{l} - \rho \underline{r} - \underline{b} = \underline{0} \quad 18.$$

This means that the vectors \underline{l} and \underline{r} must be coplanar with \underline{b} (obviously!), a condition which is satisfied by Relative Orientation. R.O. of dependent pairs requires the fixation of the rotation matrix \underline{R} which is a function of ω , ϕ and χ and the second and third components of the base, b_y and b_z in conventional terminology.

The condition of coplanarity stated by 18. may also be expressed in determinant form:

$$D = \begin{vmatrix} l_1 & r_1 & b_1 \\ l_2 & r_2 & b_2 \\ l_3 & r_3 & b_3 \end{vmatrix} = 0 \quad 19.$$

b_2 and b_3 are the linear elements of orientation, while r_1 , r_2 and r_3 depend on ω , ϕ and χ .

By assuming certain values of the elements of orientation ω , ϕ , χ , b_2 and b_3 as a first approximation, approximate values of l_i and r_i may be calculated which require further corrections. Differentiation of D , first with respect to the elements of orientation and subsequently with respect to l_i and r_i for the purpose of adjustment, gives the following observation equation:

$$f(d\omega, d\phi, d\chi, db_2, db_3) + D = \\ -(X_1 dl_1 + X_2 dl_2 + X_3 dl_3 + Y_1 dr_1 + Y_2 dr_2 + Y_3 dr_3)$$

where X_i and Y_i are the cofactors of the elements l_i and r_i in the determinant respectively (e. g. $Y_1 = -(l_2 b_3 - l_3 b_2)$). The left hand side need not be further developed for the purpose of this paper. The right hand side can be simplified when dealing with approximately tilt free pictures, whence $\underline{L} = \underline{R} = \underline{I}$ and $dl_i = dx_i$ and $dr_i = dy_i$. Furthermore $dx_3 = dy_3 = 0$ because the principal distance as such is not adjusted during R.O. In this manner the observation equation becomes

$$f(d\omega, d\phi, d\chi, db_2, db_3) + D = - (X_1 dx_1 + Y_1 dy_1 + X_2 dx_2 + Y_2 dy_2) \quad 20.$$

There will be as many such equations as points used for relative orientation. It is noted, therefore, that the problem is formulated in terms of equations 12., with the right hand sides of 20. giving equations 11. of paragraph 4. If the right hand side of all equations 20. is given the name v_i instead of y_i as in 11. to avoid confusion, the weight coefficients of the quasi-measurements D are then obtained in the fashion of paragraph 4:

$$(vv) = \begin{vmatrix} X_1 & Y_1 & X_2 & Y_2 \end{vmatrix} \begin{vmatrix} (x_1 x_1) & (x_1 y_1) & (x_1 x_2) & (x_1 y_2) \\ (y_1 x_1) & (y_1 y_1) & (y_1 x_2) & (y_1 y_2) \\ (x_2 x_1) & (x_2 y_1) & (x_2 x_2) & (x_2 y_2) \\ (y_2 x_1) & (y_2 y_1) & (y_2 x_2) & (y_2 y_2) \end{vmatrix} \begin{vmatrix} X_1 \\ Y_1 \\ X_2 \\ Y_2 \end{vmatrix} \quad 21.$$

The adjustment then is ultimately determined by the matrix of weight coefficients of the measured co-ordinates in the pictures, and that matrix depends on the real errors in the recorded picture co-ordinates. After the unknowns of relative orientation have been determined by

successive approximations the ultimate spatial co-ordinates must still be calculated, a process which is considered outside the scope of this paper.

Coming to the stated subject of this paragraph, the sources of error will now be examined. The co-ordinates will be subject to:

- (1) a parallax error
- (2) a pointing error
- (3) a random film shrinkage
- (4) systematic errors.

The systematic errors are those remaining after corrections for distortion, refraction etc. have been applied to the best of our knowledge.

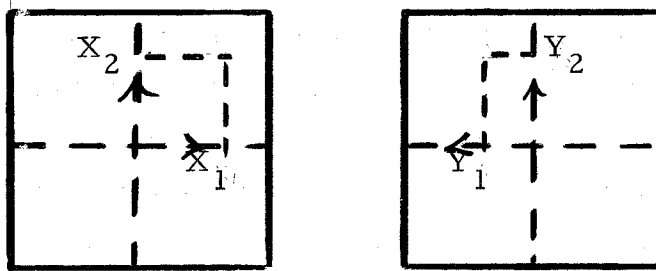

Figure 14.5 Diagram of the measured quantities in analytical photogrammetry.

For the purpose of the theoretical investigations of this paper these systematic errors are taken to be conformal to the third degree, viz.

$$dz = c_0 + c_1z + c_2z^2 + c_3z^3 \quad 22.$$

where

$$z = x_1 + ix_2 \text{ and } c_j = a_j + ib_j$$

After much mathematical manipulation which is not given here, and separating the real from the imaginary components:

$$\begin{aligned} dx_1 &= f(x_1, x_2, a_j, b_j) \\ dx_2 &= g(x_1, x_2, a_j, b_j) \end{aligned} \quad j = 0, 3 \quad 23.$$

As the errors are systematic and therefore the same on both photographs, there is also

$$\begin{aligned} dy_1 &= f(y_1, y_2, a_j, b_j) \\ dy_2 &= g(y_1, y_2, a_j, b_j) \end{aligned} \quad j = 0, 3 \quad 24.$$

What matters of course is how large these systematic errors could be in terms of standard deviations of a_j and b_j , not how large they are because if that were known they would be eliminated and no residual systematic errors would exist.

After further simplification the error pattern is

$$\begin{array}{l} dx_1 = f + dx + \frac{1}{2}dpx + dr_1 \\ dy_1 = f + dx - \frac{1}{2}dpx \end{array} \quad \left| \begin{array}{l} dx_2 = g + dy + \frac{1}{2}dpy + dr_2 \\ dy_2 = g + dy - \frac{1}{2}dpy \end{array} \right. \quad + ds_1 \quad + ds_2 \quad 25.$$

Where f and g are the functions 23. and 24. calculated for

the appropriate co-ordinate values,
 dx the random pointing error parallel eyebase,
 dpx the random parallax error supposed to be equally distributed on either side of the feature being pointed at,
 dy , dpy similar errors perpendicular to eyebase and
 dr , ds random errors of irregular film shrinkage.

With 25. the weight coefficients in 21. can now be calculated, e. g.

$$\begin{aligned}
 (x_1 x_1) &= (ff) + (xx) + \frac{1}{4} (pxpx) + (rr) \\
 (x_1 y_1) &= (ff) + (xx) - \frac{1}{4} (pxpx) \\
 (x_1 x_2) &= (fg) \\
 (x_1 y_2) &= (fg) \quad \text{etc.}
 \end{aligned}
 \tag{26.}$$

These calculations are based on the assumption that the pointing and parallax errors are not correlated, that there is correlation freedom between these errors parallel and perpendicular to eyebase and of course that the random errors of film shrinkage are correlation free. Finally (fg) and (ff) have to be calculated using the corresponding co-ordinate values for which the weight coefficients are determined with the aid of 23. and 24. assuming certain standard deviations for a_j and b_j . The whole thing becomes involved to such an extent that a practical solution can only be obtained by placing all quantities in dimensioned arrays in Fortran and calculating the relevant quantities in routine fashion using matrix multiplication. From 26. it is evident that the systematic errors consistently contribute to correlation (also between measurements of different points of relative orientation!) and that the pointing and parallax errors only contribute towards the correlation between the same co-ordinates (x_1 and y_1 , or x_2 and y_2 respectively) of the same point of relative orientation. The random error of film movement only adds to the weight coefficient and thus variance of the particular co-ordinate.

8. Aim and Conclusion

At the time of writing this paper a Fortran IV programme was being compiled in sections, each section being added to the whole after testing. The programme includes all concepts embodied in paragraph 7. The aim of this project is not so much to find out what sources of error contribute to the propagation in a triangulated strip and to what extent but rather to see whether, after assuming a theoretical propagation of errors, it makes any significant difference if this error propagation is adjusted rigorously or not. Suppose an approximate adjustment resulting from the omission of weight coefficients, which should really be included according to the theoretical pattern, produces a result no worse or significantly worse than a rigorous adjustment. If that were so one may save oneself the trouble of finding the true error propagation. On the other hand, if the difference is significant, then it becomes necessary to estimate carefully the variances of the various sources of error so that the appropriate matrix of weight coefficients may be set up.

References

- (1) P.G. Hoel. Introduction to Mathematical Statistics, John Wiley and Sons (Intern. Ed.), 1962.
- (2) J.M. Tienstra. Theory of the Adjustment of Normally Distributed Observations, Argus, 1956.
- (3) E.H. Thompson. The Theory of the Method of Least Squares, Photogrammetric Record, Vol. IV/19, 1962, pp. 53-65.

DISCUSSION ON PAPERS NO. 12, 13 AND 14.

Chairman: Dr. G. Konecny, University of New Brunswick.

L.A. WHITE: A systematic error does not propagate according to the general law of propagation of errors. BERVOETS uses the term "systematic error" for a quantity which introduces correlation and this is incorrect. Only when the systematic error has an associated error distribution can it introduce correlation. In this case, the systematic error becomes just another variate similar to l_1 and l_2 .

BERVOETS: I don't agree.

WHITE: As pointed out in your paper, the geometry of the data affects the results. In this case, by simulating data on a computer we limit ourselves to the particular model chosen. What would be more useful would be an analytical investigation into the behaviour of the vector representing the difference between the fully correlated and partially correlated solutions as it is then independent of any particular geometry.

BERVOETS: I agree with WHITE but would like to point out that it is simpler to simulate on the computer.

WHITE: There is a close analogy between survey adjustments and frame structures. This type of problem has been investigated in structural analysis where it is called the "Cut Out" problem.

P. JONES: While BERVOETS' method is satisfactory for a single strip, its extension to more complex combinations is difficult. If large systematic errors exist, they tend to mask the accidental component.

L. DOWMAN: What criteria do we apply for using the variance - covariance matrix in Aerial Triangulation?

BERVOETS: We always require the variance - covariance matrix in any adjustment, unless in particular circumstances, there is no correlation. It is not always easy to say whether this correlation is present.

G.G. BENNETT: Mention has been made of the use of the normal distribution. I would like to draw attention to a paper by A.B. Sunter in the Canadian Surveyor¹ which says that a normal distribution is not a necessary pre-requisite for a least squares adjustment. Least squares will give the best result for a number of other distributions.

J.G. FREISLICH: How are estimates of variance made and what effect does this have on the adjustment process?

BOMFORD: If no estimate is made for the variance, it is equivalent to unit weight being assumed for all observations. In geodesy, it is always possible to estimate the standard error of observed quantities. The Rainsford procedure of adopting unit weights for all quantities is only justified if distances are in feet. It is a serious criticism of an adjustment procedure that the results depend on the units adopted.

KONECNY: All standard errors can be estimated but certain systematic errors cannot be eliminated.

JONES: Professor Wolf has investigated the effects of errors in the weight matrix and these had insignificant effects on the final result. It is preferable to use estimates of errors from a knowledge of the capabilities of the instruments used.

ALLMAN: It is normally quite valid to assume covariance for observed quantities to be zero in geodesy. Covariance of derived quantities can be calculated by formula.

¹A.B. Sunter. Statistical properties of Least Square estimates. Canadian Surveyor, XX, 1, p. 36, March 1966.

BERVOETS: I can give an example in which no significant difference was obtained in the adjusted quantities irrespective of whether the weight coefficient was unity or assigned.

BOMFORD: We should point out the danger of being influenced by a single example.

ALLMAN: Much depends on the mathematical model. The geometry of the figure is critical in the method of solution.

BERVOETS: It is incorrect to state that greater weights necessarily give smaller corrections.

K. LEPPERT: I question the last statement. After all if we apply an infinite weight in a solution, then the quantity must remain fixed.

F.S. EDWARDS: Are field observations really correlation free? For example the effect of profile on the measurement both of angle and of distance. Can these be detected?

ALLMAN: It should be initially assumed that the observations are correlation free. The adjusted values should be tested statistically to see if the presence of correlation effects is indicated.

JONES: But the tests are not sufficiently critical. How large should an error be before it shows up in an F - test? On a national network, an error will have to approach the proportions of a gross error before it can be picked up.

BERVOETS: I agree.

ANGUS-LEPPAN: We expend an enormous effort in adjusting our observations, to deal with accidental errors. It is equally important to deal with systematic errors, so we should go to at least an equal

amount of trouble to investigate systematic errors; in other words, to produce a correct mathematical model.

A.P.H. WERNER: This shows in precise levelling when, over very long distances, systematic errors behave like accidental errors.

BOMFORD: All systematic errors should be eliminated by adopting adequate observing routines.

B. PURINS: In many cases Least Squares is not necessary. In the Trigonometric Branch of the Lands Department we use iteration methods of solution for example for adjusting level networks.

ALLMAN: An iteration solution though it will eventually give the right answer is very inefficient. A method which produces the most probable solution according to a chosen mathematical model is available and is greatly to be preferred.

KONECNY: This method effectively takes correlation into account in producing a solution.

ALLMAN: I would like to know from BOMFORD how often, in the adjustment of large networks, large adjustments were due to the geometry of the figure and not to the observations themselves.

BOMFORD: In the geodetic adjustment of Australia, we initially started off using Rainsford's unit weights. Later we introduced weight coefficients according to standard errors adopting 0.5" per direction; 0.7" per angle; 1" per single-ended Laplace direction and (0.1 ft. + 3 p. p. m.) for tellurometer lengths measured on 2 separate days.

In the Australian network adjustment changes in the values of the standard deviations made no great changes in station co-ordinates.

Using the above values, the adjustments in a great many cases were of the order of 0.3" in direction and 0.3 ft. in length. Large errors were always assumed to be due to observation.

WERNER: Should the term "weight" be used? A simpler and less misleading word should be used. The estimated misclosure should be used instead of the actual closure obtained.

ALLMAN: I suggest the use of the term "weight coefficient" instead of the commonly used "weight".

WHITE: Modern error theory was common knowledge 10 years ago. Why is it that government departments are only now thinking about the use of these techniques? What is the best method for getting the message across from the universities to the departments concerned?

BOMFORD: I consider that this is due to the lack of an adequate textbook on the subject written in a manner in which a non-mathematician could understand it. I would like to know whether universities were at least teaching the use of variances and co-variances in adjustments.

HARLEY: The University of Queensland is starting to teach this theory.

Members of the Universities of Melbourne, New South Wales and Sydney said that this had been incorporated in their courses for some time now and their graduates were having difficulties in convincing their employers of the necessity for the use of these methods.

PAPER NO. 15

CONTROL SURVEYS FOR PHOTOGRAMMETRIC MAPPING
AT LARGE SCALES.

by

W.A.G. Mueller.

Abstract. This paper describes a general outline of field surveys carried out for terrestrial and aerial mapping at large scales for the planning, design and construction of the Snowy Mountains Hydro-Electric Scheme. Typical results are discussed and methods are described with which extreme terrain difficulties were overcome.

1. Introduction

In the carrying out of engineering works there is need for large scale mapping of construction sites. On the Snowy Mountains Scheme much of this detailed mapping was carried out by photogrammetric means. In general the large scale mapping was between scales of 1 inch = 200 ft and 1 inch = 20 ft, with 10 ft or 20 ft and 2 ft contours respectively. The smaller scales were used for preliminary designs of large structures such as dams, and the larger scales were used for precision surveys for volume computation for payment purposes. Intermediate scales were used for more detailed design of structures, layout plans, geological detail mapping, township planning and other associated construction activities.

Aerial methods covered the full range of the above scales, whilst terrestrial photogrammetry produced plans only at scales of 1 inch = 50 ft and larger.

Field equipment, photogrammetric instruments and methods used were as follows:

Cameras:	Two Wild Photo-theodolites, $f = 165$ mm, plates 10 cm by 15 cm; One Wild RC8 Aerial Camera, $f = 115$ mm and $f = 210$ mm, mounted in a DeHavilland Beaver aircraft;
Plotters:	One Wild A7 Autograph; One Zeiss Stereotop;
Methods:	Stereophotogrammetric methods of model restitution; geometric evaluation by contouring, cross sections, or by model co-ordinates;
Field Survey Instruments:	Wild T2 and T3 theodolites, 2 m subtense bar, Tellurometer, geodimeter, automatic levels.

2. General Control Requirements for Large Scale Plottings

Geodetic Datum. The overall size of the Snowy Mountains Scheme and the proposed interconnection of its various projects made it imperative to relate all large scale mappings to a common geodetic datum.

Initially, only half a dozen stations of an existing first-order triangulation chain were available in the southern Alps of N.S.W. The Authority's surveyors extended this chain and spread first-order control over an area embracing more than 3,000 square miles of mountainous country. This was further broken down by 2nd, 3rd and 4th order triangulation, which established a total of 1,300 new control stations. Their horizontal positions were determined in a single plane rectangular co-ordinate system.

At the same time about 800 miles of precise levelling carried a common level datum into all project areas establishing a network of some 1,200 benchmarks.

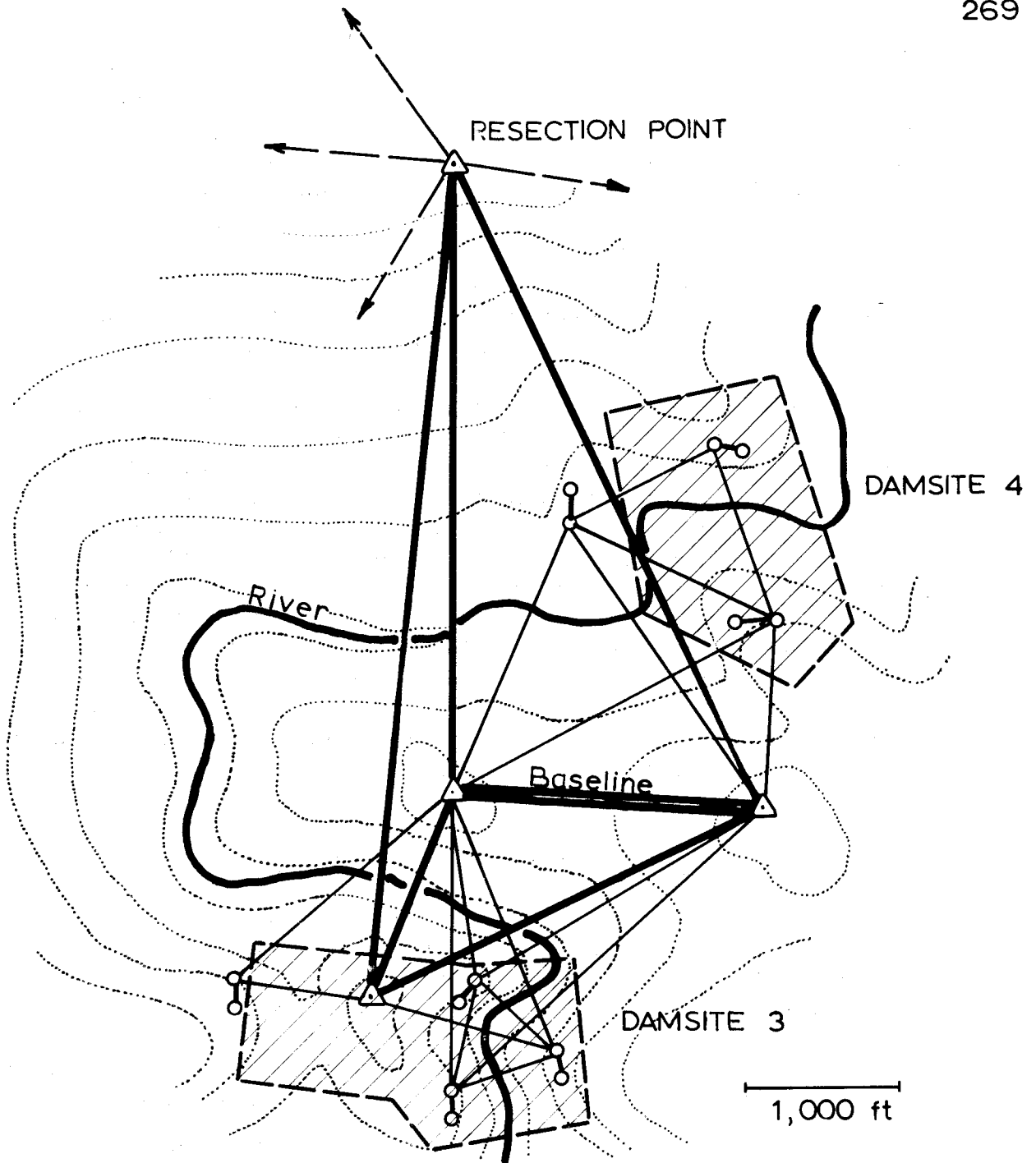

FIG.15.1 TYPICAL CONTROL DIAGRAM FOR THE LAYOUT OF 7 BASELINES OF AN EARLY PHOTOTHEODOLITE SURVEY FOR TWO ALTERNATIVE DAM SITES ON THE UPPER TOOMA RIVER.

FROM EACH BASE LINE ONLY ONE POINT IS PART OF THE TRIANGULATION CONTROL NETWORK. THE SCALE WAS DERIVED FROM A BASE MEASUREMENT WITH THE 2m SUBTENSE BAR, OBSERVED IN 6 SECTIONS OF 250 ft, WITH AN ACCURACY OF 1:15,000. (THE LENGTHS OF THE PHOTOTHEODOLITE BASELINES ARE EXAGGERATED).

The prime purpose of these new trigonometrical stations and benchmarks was of course to provide reference points for detailed field surveys during the planning and design stages and for the location of all major engineering structures during the construction stage.

The fact that these dense control networks were concentrated in each major project area provided at the same time, unique and ideal conditions for the establishment of control for large scale photogrammetric surveys, whether they were aerial or terrestrial in nature.

During the first five years of intensive investigation surveys, when the dense control network was not established yet, the photo-theodolite was often the first survey instrument on, or near the site. Then the photogrammetric surveyor had to reach out for the SMA co-ordinate and level datum by observing a resection on higher ground and running a traverse to the actual site to be surveyed. The 2 m subtense bar together with the Wild T2 which is part of the photo-theodolite equipment was extensively used for this purpose. Under these conditions the accuracy of the grid reference for any one of the photo-theodolite stations may have been ± 2 or 3 feet only. However, the accuracy in the relative position of all baselines and control points within one photo-theodolite survey always had to be ± 0.1 ft to guarantee a proper fit between overlapping stereo models.

3. Control Surveys for Terrestrial Photogrammetry

The Single Stereo Model. For the restitution of a terrestrial model all 12 elements of the absolute orientation are known, or have been determined by conventional field surveys, i. e. for each pair of stereo photographs:

- (1) the co-ordinates and RLs. of the two camera stations of a base line are computed from field observations,
- (2) the grid bearings (ϕ_1 and ϕ_2) of the camera axis during exposure are related to the bearing of the base line, (normally $\phi_1 = \phi_2$),
- (3) the tilts (ω_1 and ω_2) of the camera axis during exposure are predetermined, (normally $\omega_1 = \omega_2$),
- (4) the camera rotations (χ_1 and χ_2) have been made equal to zero by levelling the photo-theodolite before each exposure.

Any deformations in the reconstructed model are caused by residual lens distortions, by errors in recovering the interior orientation of the camera, and by the limits in the accuracy of response with which the data of absolute orientation can be recovered in the restitution instrument.

The effect and propagation of the above errors is promulgated by the extreme base: distance ratio of 1:15. The result is that planimetric errors of photogrammetrically determined points increase in proportion to the square of the distance from the base.

Therefore, co-ordinates and heights are required for at least 2 control points located in the background of the model (i.e. at the longest distance from the base) and for one control point located in the foreground of the terrestrial stereo model. An ideal location of the 3 control points in relation to the base line is shown in Figure 15.2. The importance of this control arrangement is demonstrated by the following analysis of model errors.

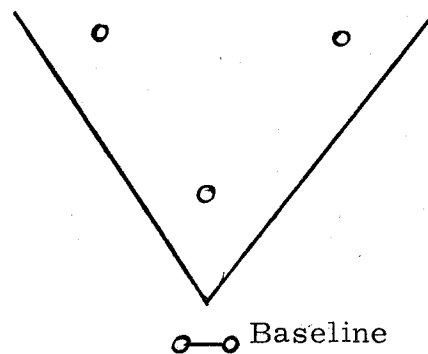

Figure 15.2 Ideal location of three control points for terrestrial stereo model.

- (1) If the planimetric errors observed in all 3 control points are in proportion to their distances from the base, a scale correction is effected by adjusting the b_x setting in the plotter.
- (2) If the planimetric errors observed in all 3 control points are in proportion to the squares of their distances from the base, an affine scale correction is effected by the introduction of a minute convergency (or divergency) into the ϕ settings of both projectors.

- (3) If the height errors observed in all 3 control points are constant, the height counter of the plotter is adjusted by a datum shift equivalent to the observed errors.
- (4) If the height errors observed in all 3 control points are increasing with the distance from the base, both ω tilts of the projectors are adjusted.

A terrestrial model which has been reconstructed from carefully determined elements of the absolute orientation, usually needs only very minute adjustments to satisfy ground control data for position and height. The appropriate corrections to the relevant instrument settings are often close to the very limit of mechanical response in a high precision instrument. Therefore, the function of control is more or less a check, a "final touch", to the scale and positioning of the model into a given grid system of co-ordinates and heights.

Model deformations become detectable in horizontal position if they are larger than 0.1 mm at plotting scale, and in height if they are larger than 0.03 mm at model scale. It follows that for plotting scales of 1 inch = 50 feet and larger, the co-ordinates and heights of all control points must be determined to an accuracy of ± 0.1 ft. It is evident that the delineation and description of each control point must be distinct within the same limits of ± 0.1 ft or better. Therefore, artificial targets or white painted pegs are preferred to give positive and precise definition for theodolite observations as well as for setting the measuring mark in the plotting instrument.

To realise the above accuracy in the compilation of the plan the co-ordinates of the two base stations have to be corrected by the off-set of the camera lens (rear nodal point) from the vertical axis of the instrument to which the station co-ordinates refer. This correction, with its three-dimensional components, varies in position and height for each individual stereo pair. (Figure 15.3)

The Terrestrial Survey with Multiple Stereo Models. In the precipitous river gorges of the Snowy Mountains some early investigation surveys for major engineering structures took up to 10 baselines to provide continuous coverage within a specified area. Each baseline may have rendered up to 6 pairs of photographs resulting in a total coverage of 40 - 50 stereo models.

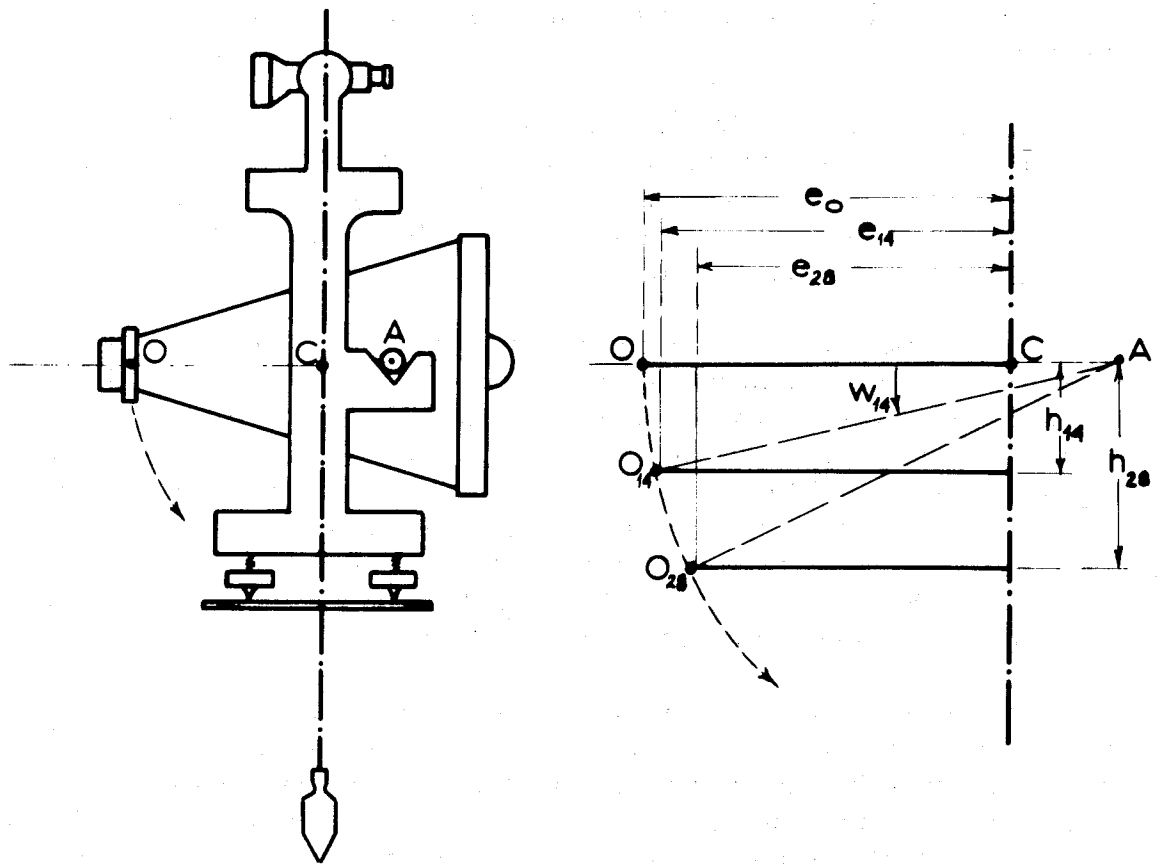

FIG. 15.3. REDUCTION OF COORDINATES AND HEIGHTS TO THE LENS OF THE PHOTOTHEODOLITE.

A=Horizontal tilt axis of camera.

C=Point on vertical axis of phototheodolite.

O=Rear nodal point of camera lens.

O_{14} =O when camera is tilted by -14 grades.

O_{28} =O when camera is tilted by -28 grades.

e=Horizontal corrections to obtain coordinates for the camera lens at tilts of 0, -14 and -28 grades.

h=Height corrections to obtain reduced levels of the camera lens at tilts of -14 and -28 grades.

AO=Constant distance of 0.40 ft.

CO=Constant distance of 0.30 ft.

Apart from regular overlaps between stereo models belonging to one and the same baseline, the gross coverage gained by any one base will partially overlap the area covered from an adjacent or opposite baseline.

To exploit fully the "inner" accuracy of ± 0.1 ft with which a single stereo model can be restituted, we have to maintain this accuracy in the assembly of adjoining stereo models. This condition must hold not only for those models belonging to one base but for all stereo models photographed for a particular survey.

The relative accuracy in position and height for all baselines and control points must be better than ± 0.1 ft. This was achieved by minor triangulations which connected one point of each baseline by a series of fully braced quadrilaterals. The scale was always independently derived from suitable subtense bar measurements to an accuracy of 1:10,000. By using constrained centring equipment triangle misclosures were seldom found to be larger than 10 seconds of arc for side lengths as short as 500 feet or less. The transfer of reduced levels by reciprocal vertical angles always closed within ± 0.03 ft.

The horizontal angles on the main base stations were usually observed in two complete arcs, whilst the interesections for control points were observed in 2 semi-arcs. Reciprocal vertical angles were observed between the main base stations and between stations of one and the same baseline. Vertical angles to control points were read in both faces from at least 2 different base stations.

Following the extension of third and fourth order triangulations into the project areas, subsequent photo-theodolite surveys for the design and construction stages were greatly facilitated by the existence of these new control surveys, as they provided suitable control stations for the co-ordination of baselines and control points. The demand on high accuracy in the relative position of baselines and control points could now be more easily satisfied by locating most of the camera stations directly over or at least near, existing control stations, whilst other control stations appearing in the photographs provided excellent control for the model restitution, and for the tie between individual models.

Types of Control Points. Photo control points for terrestrial surveys may be represented by natural features of the terrain or by artificial markings placed on the ground. The type of terrain usually decides the choice between natural or artificial control points.

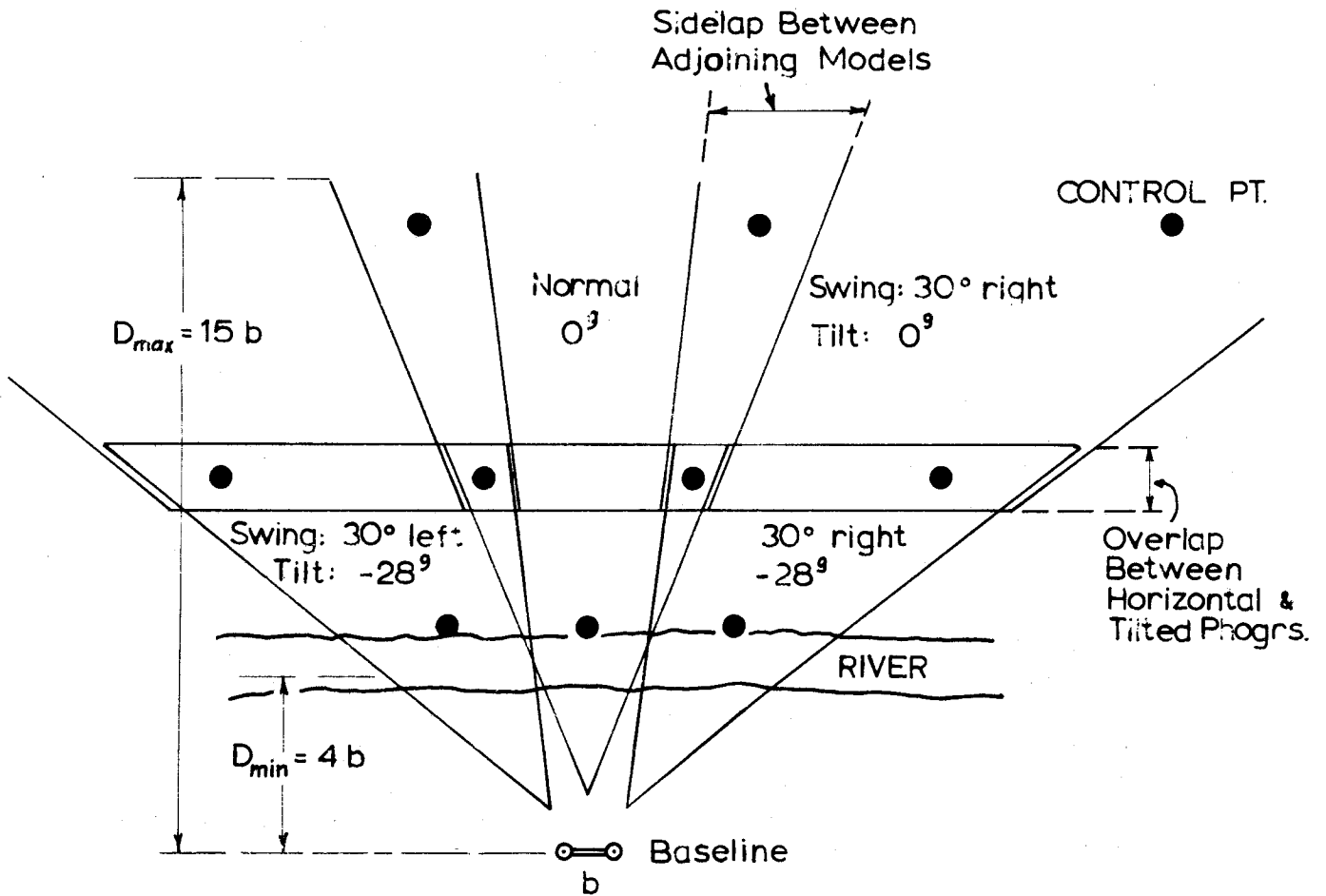

FIG. 15.4 IDEAL LAYOUT OF CONTROL POINTS FOR SIX STEREO PAIRS OF PHOTOGRAPHS TAKEN FROM A SINGLE BASE LINE. THE LOWER PORTION OF THE VALLEY IS COVERED BY 3 STEREO PAIRS UNDER A CAMERA TILT OF -28 GRADES. THE HIGHER GROUND IS COVERED BY STEREO PAIRS TAKEN UNDER 3 DIFFERENT "SWINGS" AND WITH THE CAMERA AXIS HORIZONTAL OR UNDER A TILT OF -7 GRADES.

When, as in deep river gorges, access is difficult, natural features are selected. On steep slopes with rocky cliffs, natural control points can be found in abundance. The only disadvantage is that detailed sketches have to be drawn by the surveyor to describe each point in detail and its position relative to other control points, so that the operator of the plotting machine recognizes the actual point without any shadow of doubt. Surveyors who have no artistic skills for making sketches, can use a Polaroid camera, which provides them instantly with paper prints, on which the necessary annotations of control points can be made.

Natural features should be small in size, but easily identifiable by a characteristic or peculiar shape; they should have a distinct point of reference, preferably in a free-standing pinnacle so that this can later be approached in the plotter by the measuring mark from all directions for accurate settings.

In selecting natural features for control points consideration must also be given to the prevailing light conditions. A sharply pointed rock or a needle-tipped branch may appear very distinct in sunlight, when their shape is defined by contrast between highlights and shadow. However, under dull and flat light conditions (cloud shadow) which are preferred for photography, such a control point may be hardly recognisable.

If the terrain is more or less featureless, but easily accessible, artificial targets may be placed on the ground prior to photography. Artificial control points may be painted boards or light-weight panels. White indicator pegs (3" by 1", and 2 feet long) have proved to be most satisfactory. As they can be easily recognised later on the photographs, no great demand is made on the surveyor's sketch, which merely has to identify each peg by its number.

Another distinct advantage of artificial control points is that, after deciding on the swing and tilt of each of the proposed photographs, and thereby having determined the coverage of each stereo model, the surveyor standing on the baseline can direct an assistant by signs (or by two-way radio) into the appropriate positions where a control point will be most effective.

Criteria for the location and distribution of control points are:

- (1) its point must be positioned either in the foreground or background of a particular model,

- (2) it should fall within the overlap of adjoining models.
A carefully located control point can serve up to 4 models.
- (3) it must be visible for intersection not only from both stations of the relevant baseline but also for observation from at least one other base or control station.

4. Control Surveys for Large Scale Mapping from Aerial Photographs

The Single Stereo Model. The geometric conditions for the restitution of an aerial model are much more favourable than those under which a terrestrial model is being reconstructed: The base:height ratio is much smaller, i. e. between 1:3 and 1:1 as against 1:15 for terrestrial; the depth of the aerial model or the range of stereoscopic measurements (height) is generally within $\pm 0.05h$ to $\pm 0.1h$, whilst the depth (distance) of a terrestrial model can be infinity and is limited only by the accuracy of stereoscopic measurement which confines the depth to $\pm 0.6d$.

The geometric stability of the aerial model gives it homogeneous strength. It can therefore be reconstructed by using the geometric properties of the two photographs themselves. Only in exceptional circumstances are "outside" control data used for this purpose.

The reconstruction of the aerial model is achieved by the process of "Relative Orientation", which in terms of projective geometry solves the 5 unknowns in the spatial relation between the two photographs.

The remaining 7 unknowns of the absolute orientation are solved with the aid of control data by positioning at least 3 model points in correct relation to the co-ordinates and heights of their corresponding ground control points.

Layout of Control. As the relative accuracy of photogrammetrically determined distances in a single stereomodel increases with the length of the distance, the two control points which are used for scaling should be as far apart as practicable.

The known elevation of the third control point in conjunction with the elevation of the two ground control points used for scaling provide the means for levelling the model. It can readily be seen that the three

control points will be most effective for accurate levelling if their connecting lines form a triangle as large in area as possible.

In large scale work for engineering purposes at least 4 control points, preferably 5 - 6 control points are required for each model in order to increase the accuracy of relative and absolute orientation.

The layout and requirements of photo control points will normally be specified for each particular project. However, the surveyor may sometimes be forced to alter the proposal when existing control stations have been destroyed or other difficulties arise in the field.

Airphoto Control Point. From each control station, established either by geodimeter radiations, by triangulation or chain traversing, two well defined ground features which can be seen on the photographs are fixed by bearing and tape distance for position and by a vertical angle for height.

The criterion for selecting good photo control points is the certainty and precision with which their described feature and point of reference can be interpreted and measured by the surveyor in the field and later by the photogrammetrist in the stereo model. This precision should be $\pm \frac{\text{Photo-scale factor}}{30,000}$ feet.

Modern photogrammetric precision systems are capable of higher accuracies, which can be fully utilized only by using artificial control points.

Well-defined, natural features in order of preference are:

- an isolated tuft of grass (ground level).
- a small rock.
- one corner of the roof of a hut.
- a small tree stump (ground level).
- a small ant hill or rabbit warren (centre, at ground level).
- a corner of a big rock outcrop or of a big boulder.
- a corner post or junction of fence lines (ground level).
- a small bush (ground level).
- one end of a log lying on the ground (ground level).
- an isolated boulder (highest point or ground level).

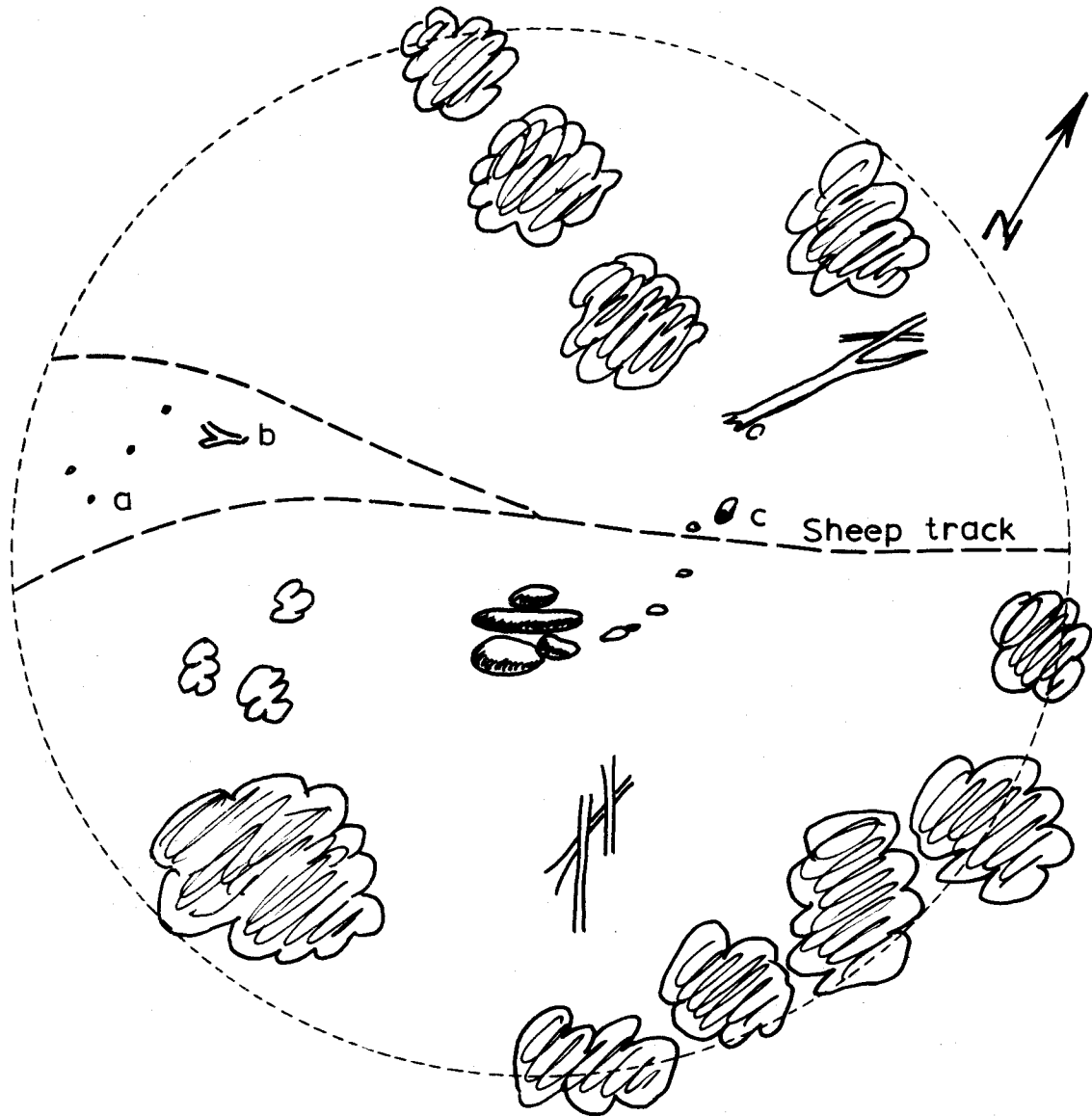

FIG. 15.5 TYPICAL IDENTIFICATION SKETCH

- APC 13 a= Small bush (grd. level)
 b= End of small log (grd. level)
 c= Rock on northern side of sheep track.

Photo Identification. Field identification on the photographs must be made with a pocket stereoscope. The stereoscope not only enlarges the photographic image, but stereoscopic vision doubles the resolving power and with it, the small detail which can be seen on the photographic prints.

Identification should be made for two different features to be fixed from one and the same station within a radius of 100 feet. If positive identifications are difficult a third one of a very prominent feature (big tree, track intersection etc.) will be a helpful guide for the operator to lead him to the actual photo control points to be observed.

The location of the control point is indicated on the photographs by a circle of 1/4 inch diameter, drawn with a chinagraph pencil, leaving the actual control point images free in its centre to be identified later in the office.

A large scale sketch on the field observation sheet shows for each control point the shape of the identified features and their relative orientation and position to prominent and characteristic features surrounding them. The area shown in the sketch should cover the field encircled on the photograph. It should not be overdone by showing anything which can be seen in the field but cannot be detected on the photographs. Nor should the content of the sketch be obscured by entering field notes, such as observed angles and distances from the control station. The sketch has to be oriented by a north point.

The most common mistake of a surveyor who had no previous experience in photo identifications arises from an urge "to be on the safe side". So, six or more natural features are selected which are very carefully co-ordinated without checking what type of image they have produced, or whether they show up at all on the photographs. Or, after a first briefing, the surveyor was misled by the opinion that the operator of a big plotting machine would be able to see smaller detail than was visible on the paper prints under a field stereoscope.

It was found that such anxiety could be relieved by furnishing the surveyor with a sketch of the proposed control point made by the photogrammetrist. This of course meant a severe restriction on the ingenuity of the field surveyor, which could have lead to other frustrations if the proposed layout of the control station network was not the easiest

and most economical one to be realised in the field. Therefore, the prefabricated sketches can only be supplied for such control points for which no better alternative position is seen. The advantages of such pre-drawn sketches are eminent:

- (1) they are drawn up from photographic detail only,
- (2) they are drawn with the aid of more elaborate office equipment and under conditions not hampered by bad light, wind or weather,
- (3) they are made by the photogrammetrist, who always complains about surveyors' sketches,
- (4) they give the inexperienced surveyor confidence and save him costly time in the field.

However, it is essential that the photogrammetrist is familiar with all stages and methods of field work, that he has full knowledge of all existing control stations in the area, that by careful studies of the photographs under a stereoscope he has made a thorough "reconnaissance" and that he in fact has executed the survey mentally, thus verifying the practical possibility of his proposals.

Each sketch shows some big trees or other prominent features, and in relation to these some minor detail of characteristic shape and appearance. Three or four of these are numbered and described on a space beside the sketch as "a = single rock", "b = small bush" or merely as "c = white patch at ground level" etc. From this selection the surveyor makes the final choice in the field, and observes angles and distances to them, so that co-ordinates and heights may be determined.

Once the surveyor has learnt how to use the stereoscope to his best advantage he can still further improve on the quality of photo control points; whilst identifying on the ground the features shown in the sketch he may find some small object on the ground of very clear cut definition, such as a small rock which had not previously been shown on the sketch made by the photogrammetrist. When the surveyor picks up his stereoscope again and makes a very concentrated search for this particular object on the aerial photographs, he will often find it as a small, faint dot only. As soon as the surveyor can definitely and positively associate this small faint dot in the photograph with an object he found on the ground, he has identified the most effective and most valuable control point. Being in possession of a ready made sketch he merely enters the new control point in its proper relation to other features shown.

The repeated "setting up" of stereoscope and photographs in rather awkward conditions (on the chainman's back or on his own shaky knees) will often discourage the surveyor to use the stereoscope right through the process of identification. The use of Zeiss Photo-interpretation Field Outfits has greatly facilitated this task in that it enables the surveyor to walk and climb around with the photographs and stereoscope firmly secured to an easel and always ready for intermittent stereoscopic viewing.

The reduced levels observed for all identified features should refer to ground level in its immediate vicinity. If such features are on a slope the spot height should refer to either side of the identified object, estimated to be on the same contour height as the centre of the object itself.

Benchmarks for vertical control, often located along roads, can normally not be identified on the photographs. Here a short levelling (mostly a single back and fore sight) can transfer the level to the road surface at a significant curve, over a culvert or into the intersection with the prolongation of a fence line. The identification of such a height control point must be positioned more accurately as the gradient of the road increases.

If vertical control has to be spread over larger areas (storage areas) this can be established by observing from any control station vertical angles only to bare hill tops, prominent knobs or boulders, to the roof tops of sheds etc. The reduced levels of such objects described by "tele-identifications" can be derived from the vertical angles matched with the corresponding distances computed from model co-ordinates.

Artificial Control Points. Aerial surveys carried out during the design and construction stages are at scales of up to 1 inch = 20 feet. The highest possible accuracy is required when volumes of excavations and rock or earth fills are derived to be used as a basis for contract payments.

Here, an accurate network of permanent control stations is established, on which prefabricated targets are centrally placed prior to each sortie of aerial photography, to provide positive and precise identifications. As the same control points are used repeatedly a good relative precision between periodical surveys is guaranteed.

The targets used by the Authority consist of a 3 ft by 3 ft black heavy plastic material with a yellow circular disk of 9 inches or 12 inches diameter in the centre. Reinforced holes in the centre and on each corner allow the target to be centred over the ground mark and fastened to the ground.

From trials carried out with these targets over test fields with dense control the following mean square errors were found when measuring co-ordinates and heights from photographs taken at 2,000 ft above ground:

$$m_p = \pm 0.11 \text{ ft for position}$$

$$m_h = \pm 0.16 \text{ ft for height}$$

The potential accuracy inherent in a first-order photogrammetric mapping system calls for control surveys of high precision. This in turn demands high accuracy in identification which can only be achieved by artificial targets with ideal density contrast and of a regular shape, the size of which has to be in proper relation to the photographic scale and to the size of the measuring mark used in the plotting instrument.

Several authors in the photogrammetric literature have recommended just as many different shapes and sizes as a function of the photo scale. The theoretically recommended minimum sizes in feet vary between

$$\frac{\text{Photo scale factor}}{20,000} \quad \text{and} \quad \frac{\text{Photo scale factor}}{10,000}$$

Under conditions prevailing in the Snowy Mountains area a target size of 12 inches was found to have sufficient latitude to suit varying scales from 1:5,000 to 1:10,000 when the position of the target is only roughly known. The same targets have been seen on paper prints from photographs at a scale of 1:15,000; however, they could be detected only when their exact position was known.

The danger of targets being disturbed by weather or animals is not so acute in large scale mapping for relatively small areas, where targeting and aerial photography can be carried out in quick succession. If however, photography is delayed, all targets must be revisited and checked again. On active construction sites the targets should also be cleaned from dust and dirt immediately prior to photography.

5. Control by Photogrammetric Methods

Aerial Triangulation. Aerial triangulation is normally carried out with the same photography used for subsequent plotting or at least with photography which produces supplementary control points with an accuracy comparable to that of the photography used for plotting.

For the location and design of roads, aqueducts and transmission lines photogrammetric large scale route plans have been produced. These varied in scale between $1'' = 200$ feet and $1'' = 50$ feet and showed contours between 20 feet and 2 feet interval.

Where such routes traversed mountainous terrain or densely timbered country, the photography for plotting was taken with a narrow angle lens, from a flying height appropriate for the requested contour interval. Individual model control was provided by aerial triangulation of a wide angle lens run covering the same route.

The flying height and the disposition of the triangulation run was always designed to make the best possible use of existing control stations. Very often this could be achieved only by raising the flying height at the cost of loss in relative accuracy. However, this was justified with the reasoning that:

- (1) the number of photographs was reduced, thus giving greater inner strength in the geometric structure of the triangulation strip,
- (2) existing control stations in the marginal areas were "taken in",
- (3) the wider coverage afforded more possibilities to establish new or additional control in an economical way.

An example, in which the principle of "Minimum Control" was fully exploited, was the photogrammetric survey for the design of a 28 mile section of a 330 KV transmission line. Each of four wide-angle photo runs, comprising an average of 10 stereo models, was controlled by 3 control points only. The aerial triangulation of these runs produced an average of more than 4 control points for each of 60 stereo models of normal angle lens photography which was used for the plotting of a

contour strip map extending 600 feet either side of the preliminary alignment.

The initial control for the wide angle runs was designed to keep the errors in relative levels between adjacent tower positions within the specified limit of ± 5 feet. When the construction of the transmission line was completed, field checks revealed that the actual mean square error for a height difference along the line was only ± 2.5 feet, whilst systematic errors in height differences on distances of $2\frac{1}{2}$ miles across the line were up to 60 feet.

The accuracy in the fully controlled profile, which was observed photogrammetrically after the line had been cleared was ± 0.8 feet for height and ± 1.1 feet for a height difference. To improve the accuracy of the initial contour survey from ± 2.5 feet to ± 1.1 feet for a height difference would have involved several months of very costly control surveys in the field.

Phototheodolite. For the design of an 8 mile aqueduct along the steep slopes of the Main Range, high above the Geehi River Gorge, plans at $1'' = 100$ ft, with 10 ft contours, were required.

It became the very first project to be photographed with the Authority's own RC8 aerial camera. The proposed route was photographed with the normal angle lens from an altitude of 5,000 ft above average ground elevation in 5 runs comprising 40 stereo models from which at least 25 had to be fully controlled for mapping. The mountainous terrain caused the photo scale to vary between 1:5,000 and 1:10,000 within short distances.

Only one end of one run, at the proposed Geehi River Dam site, was reasonably well controlled by previous detail surveys carried out with the phototheodolite. The rest of the route, right to the aqueduct intake in Lady Northcote's Canyon, was absolutely bare of any existing control station.

Control was planned to be provided by a single run of wide angle photography. This was flown at 7,000 feet above average ground elevation and comprised 10 stereo models, overlapping completely the coverage obtained earlier by the normal angle lens runs. Because of

its greater coverage in width some control could be established along one edge of the run, where access was not so difficult. However, the opposite side and the end of the run was still unsupported by control. Field survey was impracticable as it took a full day's climb to get there and back, leaving no time for field work.

From a distance of 3 miles to the west a good overall view of the proposed aqueduct route could be obtained from the top of a range running parallel to it (Grey Mare Range). Three existing trig. stations located on this range formed 2 suitable bases of $2\frac{1}{2}$ miles length each for the intersection of identifiable features in small clearings to provide control for the southern end of the photo run. However, the positive identification of similar features from 3 different view points was extremely difficult. Therefore, the phototheodolite was set up and orientated on each of the 3 trig. stations. From the 3 photographs taken similar features could then be selected which also were visible on the aerial photographs. Their picture co-ordinates were measured on the negative plates, from which bearings were computed for the intersections of each control point. In a similar way were the picture co-ordinates used to compute vertical angles for height.

The mean position error from double intersections for 6 control points was found to be ± 1 foot, which corresponds to an error in the computed bearings of $\pm 6-10$ seconds of arc. The average mean square error in height was ± 0.6 feet.

From the aerial triangulation the co-ordinates and heights of 72 new control points were determined. These provided single model control for the plotting from photographs taken with the normal angle lens.

In many instances phototheodolite large scale plans have provided supplementary control for plotting from aerial photographs. The co-ordinates and height of certain plan detail was scaled off (e. g. the top of a rock), re-identified in the terrestrial photographs and then by comparison of image detail, identified in the aerial photographs.

6. Conclusion

There are no strict rules which govern the layout and the amount of field control surveys for every photogrammetric mapping project.

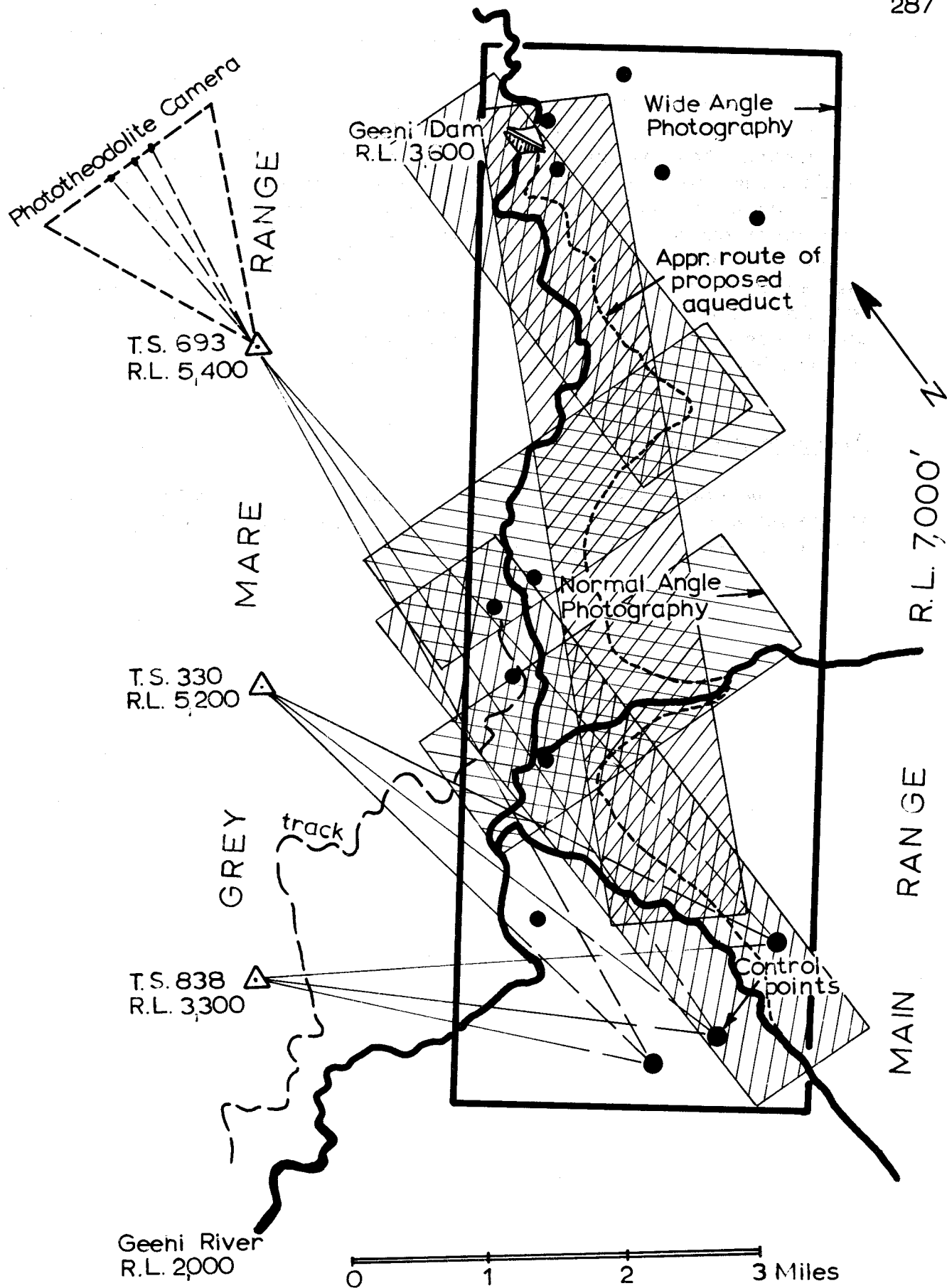

FIG. 15. 5. AIRPHOTO CONTROL WITH THE AID OF PHOTOTHEODCLITE.

In each instance the requirements of absolute accuracy have to be carefully weighed against the economy of minimum control. In photogrammetric large scale mapping for engineering purposes such minimum solutions are often satisfactory when time and deadlines have to be considered, and when accuracy requirements are confined to a relative precision in the presentation of a line profile or shape of a valley. However, plans for design and construction purposes require high absolute accuracy in position and height. These can be produced only from fully controlled stereo models. The methods of identifications as outlined in this paper have been successfully performed by surveyors who had had no previous experience in this field.

Acknowledgement.

The Author thanks the Snowy Mountains Hydro-Electric Authority for permission to present this paper. The views expressed in it are his own and not necessarily those of the Authority.

MAPPING CONTROL FOR
HYDRO-ELECTRIC DEVELOPMENT
IN TASMANIA.

by

J.W.S. Linton, D.M. Jenkins and A. Apsenieks.

Abstract. Sufficient details are presented in this paper to portray how survey control is used in the development of hydro-electric power in Tasmania. In projects of this kind the majority of uses of survey control are not specifically for mapping purposes. Some of these have been dealt with briefly from an interest point of view.

We endeavour to apply sound principles to all surveys; however, as is usual in practice, various factors influence the best intentions and compromises must be made. Even so, it has been found, generally, that surveys have proved adequate to meet the demands made on them.

1. General

It is intended in this paper to describe briefly the nature and extent of "control" surveys carried out by the Survey Section of The Hydro-Electric Commission, Tasmania.

In order to appreciate the scope of this work one or two general comments about the State and the Commission are appropriate at this stage.

Tasmania is an island of 26,215 sq. miles lying between the latitudes of 40° and $43\frac{1}{2}^{\circ}$ south. It is generally mountainous, the highest peaks being over 5,000 ft. Lowland plains are limited in occurrence and extent and much of the West and South West is virtually uninhabited. Although the State has a temperate maritime climate, fluctuations in the predominantly westerly wind circulation produce broad seasonal variations in climate. The rainfall varies from over 100 inches in the West to less than 20 inches in the East. As can be expected, these topographic and climatic factors influence greatly the manner and rate at which survey work is carried out in the State.

In 1930 the "Hydro-Electric Commission Act 1929" became effective. This Act vested in the Commission the sole right to generate, distribute and sell electricity in Tasmania. Through its various branches, i.e. Secretarial, Civil Engineering, Electrical Engineering, Power and Retail Supply, the Commission carries out the investigation, design and construction of power schemes and the reticulation of electricity throughout the State. The Survey Section is part of the Civil Engineering Branch and caters for all the Commission's survey requirements. These include most types of surveys, namely:

- Geodetic - providing the basic horizontal and vertical control.
- Photogrammetric - both Aerial and Terrestrial, providing maps etc. at scales of 400 ft. = 1 inch to 4 ft. = 1 inch.
- Topographic - Generally in conjunction with photogrammetric surveys, providing detail maps at scales of 100 ft. = 1 inch and larger.
- Engineering - Including underground, deformation and other precision surveys as well as the normal engineering surveys required for the construction of dams, power stations, flumes, canals etc.
- Cadastral - Providing surveys for all acquisitions, easements etc. required for the power developments.
- Hydrographic - Providing soundings of river beds, lakes etc. using echo sounding equipment.

It should be noted that 95⁰/o of the Commission's surveys are based on co-ordinates of the National Grid System. Major lines of construction are denoted by co-ordinates on design drawings. The advantages of a co-ordinate system fully justify the expenditure and continuance of the system.

During the last decade and a half the major project areas have been:-

- (1) The Wayatinah-Liapootah Power Development (completed).
- (2) The Great Lake Power Development (completed 1964).
- (3) The Lower Derwent Power Development (completion 1968).
- (4) The Mersey-Forth Power Development (completion 1971).
- (5) The Pieman River Area (Investigation completed).
- (6) The King-Franklin Area (Investigation proceeding).
- (7) The Gordon River Area (Investigation proceeding).

On the first four projects alone some \$250,000,000 will be expended by completion. Annual expenditure on surveys is of the order of \$500,000.

For the purpose of this paper control surveys will be classed as those which produce horizontal and vertical datums on which mapping for hydro developments can be based. The paper will include details of several specific projects, the Great Lake Power Development, the Gordon Road and King-Franklin Investigation Areas as well as details of general levelling carried out by the Commission. However, the definition of control may also be applied to more confined areas of activity such as control of a tunnel or pipeline. Alignment of a large tunnel boring machine such as was used on the Great Lake project presented interesting alignment control problems.

As regards accuracy specifications it is difficult to lay down hard and fast rules for this specialised control. The extent of the work and economics influence these standards considerably. It may be that

a tunnel control survey need only be say 1/20,000 as regards distance between inlet and outlet but may require the highest precision attainable as regards direction. One penstock may only require horizontal control to 1/8,000 and vertical control to 3rd order standards, another 1/30,000 and vertical control of the highest precision.

Surveys for the establishment of horizontal and vertical control are required at the outset of investigation of a power scheme. The general procedure is as follows:-

- (1) Selection of areas of interest from small scale mapping, i. e. 1:50,000, 50 ft. contour intervals etc. Control provided for this mapping is generally not suitable for feasibility studies.
- (2) Production of medium and large scale maps of selected areas, i. e. 400 ft.= 1 inch and larger. Horizontal and vertical control are brought into these areas by triangulation, trilateration and trigonometrical heighting.
- (3) Production of maps for design, i. e. 100 ft.= 1 inch or larger. This requires a breakdown of primary control by lower order triangulation, trilateration or traverse; levels are brought into the area by differential levelling of various degrees, depending on factors such as layout of the scheme, ease of access etc.
- (4) Engineering construction - This will include horizontal and vertical traverses in and around construction sites.
- (5) Transmission line surveys - Profile detailing is carried out mainly by tacheometric methods. Some work has been successfully completed by photogrammetric means. Control of either method is by tellurometer traverse etc. Scale of drawings: 400 ft.= 1 inch Horizontal and 40 ft.= 1 inch Vertical.
- (6) Cadastral surveys - If convenient these surveys are left until construction is completed. The work is placed on the National Grid System wherever possible.

- (7) Deformation surveys - Usually surveys of the highest precision in confined areas, performed mainly after structures are built. Control is effected by triangulation, collimation, traverse etc. using orthodox first order instruments and other specialised equipment.

Equipment. Main items of equipment used by the Survey Section include:- Wild T2 and T3 theodolites with their various attachments such as pentagonal prism, right angle eyepieces, Horrebow level etc., Tellurometer MRA3 since 1964 (MRA1 1958-1961, MRA2 1961-1964), Zeiss Ni2 Automatic Levels, parallel plates, Kern invar staves, 2 Wild A7 Autographs, EK5 Co-ordinate Printer etc. coupled with Friden Flexowriter for use with Elliot 503 Computer, 1 Wild P.30 Photo-theodolite, 1 Wild C.12 Stereo Camera (1 Wild C.120 Stereo Camera and A40 Autograph are due to be installed in June, 1967), Bendix Echo Sounder, Invar tapes and base line equipment, Galileo micrometer targets, Wild subtense bars, telemeter equipment, auto-reduction tacheometer etc.

2. Horizontal Control

Horizontal control is based on the State Triangulation. This is fairly well distributed. When not available it is extended, to first order standards, for our purposes. In most cases one primary station and azimuth are selected as datum for an area of development. Control is then extended from this datum to various points of the scheme by triangulation, tellurometer traverse etc. It has happened that an intolerable discrepancy is found when connecting onto other primary stations. This is ignored and co-ordinates based on Commission work adopted. It must be realised that some of the primary work was completed before the advent of the tellurometer and scale differences are apparent in remote parts of the State.

Little difficulty has been experienced in obtaining satisfactory horizontal and vertical closures with this work. Electric light sources are invariably used as targets. Average lines would be 5-7 miles in length with photo control line often much less, 1-3 miles. The longest lines measured have been between 30-40 miles long. Simultaneous vertical reciprocal angles are employed in trigonometrical heighting using Wild T2 theodolites. As an example of a height carried through

in this manner, one 120 mile circuit closed to less than 1 ft. Subsequent differential levelling into the area confirms that the trigonometrical heighting was within 1 ft.; this is quite adequate for preliminary investigation.

Mention must be made of the helicopter. A trial was made in 1955 and since 1958 helicopters have been used annually with great success. It is difficult now not to include as the mainstays to a survey operation the tellurometer and the helicopter. So much can be accomplished by relatively few personnel with these two pieces of equipment that comparisons with what would have been done 10 years ago appear ridiculous.

It has been our philosophy, particularly with regard to aerial photogrammetric control, to endeavour to obtain extra points in the field, particularly if the area is normally inaccessible due to terrain or weather. It pays in the long run. Certain errors can be accepted in topographical mapping but when engineering projects are concerned these errors cannot be tolerated.

The following statistics may be of interest:-

Number of lines measured by tellurometer.

1 - 5 miles	1150
5 - 10 "	45
10 - 15 "	22
15 - over "	6

Measurement by MRA3 in the Lemonthyme Tunnel. The Lemonthyme Tunnel is some four miles long and will connect the water storages of the Mersey Valley with the power stations in the Forth Valley. At approximately 17,000 ft. from its outlet a bend occurs and to check the site surveyor's determination of this bend position it was decided to experiment with the tellurometer in underground conditions.

Prior to these measurements a field calibration for determination of instrument index errors was conducted with the following results:-

Master Inst. CRT.Master Inst. DRO.

D_0	D_1	D_0	D_1
1016.698 M's	245.484 M's	1016.898 M's	245.717 M's
	291.204		291.457
	236.067		236.260
	243.680		243.896
	<hr/>		<hr/>
$\Sigma D_1 =$	1016.435		1017.330
$D_0 - \Sigma D_1 = 3 \Delta =$	+ .263		- .432
$\Delta =$	+ .088 M's		- .144
	= + .29 ft.		- .47 ft.

The underground measurements took place over two days. On the first day a section 13,500 ft. long was measured and on the second two measurements were made, one being the remaining section to 15,500 ft. and the second the complete distance.

The following results show the comparisons with the direct chained distances:-

<u>Section</u>	<u>Chained</u>	<u>Tellurometer</u> (mean of insts.)
1) 00-15475	15474.564	15474.550 (2nd day)
2) 00-13500	13486.580	13486.844 (1st day)
3) 13500-15475	1987.984	1988.082 (2nd day)
Sum 2 and 3	15474.564	15474.926

Measurements are in feet.

In the tunnel itself conditions of 100% humidity were experienced, with mist and dust still lying along the line, and it is thought this could have affected results on the first day; a full determination of meteorological conditions throughout was observed on the second day. However, the section sum accuracy is of the order 1/43,000, and as a result it is intended to use the tellurometer to check a single precise taping in future.

3. The Great Lake Power Development

In scope the project embraces a portion of the Central Plateau with elevations above 4,000 ft. falling in a steep escarpment to the plains of the Lake and South Esk Rivers. (See Figure 16.1) As some 7 miles of tunnel and an underground power station were involved, rigid surveys over this area were essential. At the time of commencement of survey the tellurometer had not arrived in Tasmania. A chain of conventional triangulation was therefore used to span the area involving three quadrilaterals and one centre point polygon, the initial starting quadrilateral containing three existing second order trigonometrical stations.

Throughout this network the maximum triangle misclose was 4".59 with an average misclosure of 1".93. The adjustment was performed by the direction method involving thirty-four normal equations and 70 directions requiring corrections.

Two years after the completion of this survey MRA1 tellurometers were purchased and introduced into subsequent control surveys in this area. The opening and closing lines of this triangulation were measured to obtain comparative results, with the following comparison:-

	<u>Computed</u>	<u>Measured</u>	<u>Accuracy</u>
Macraes - Little Billopp	36329.328	36329.426	1/360,000
Inlet - Great Lake	12067.851	12067.780	1/170,000

The Lake River, which was to carry the tail waters from the Scheme, was at times liable to flooding and as a result investigations for river improvements were necessary. A tellurometer traverse was run to provide control for aerial photography and large scale mapping. The traverse consisted of eight stations with a bearing close on existing stations of 0".51 and co-ordinate close of 1/330,000.

During this time, also, controls in proximity to the various underground works on the escarpment were fixed by mixed tellurometer and angular observations. For the adjustment of these surveys into the original framework we favoured the method Lilley has published in the "Canadian Surveyor"; this we found to be the neatest method of handling mixed observations where triangle closures were involved and the method of variation of co-ordinates was used if fixes were not in triangular form.

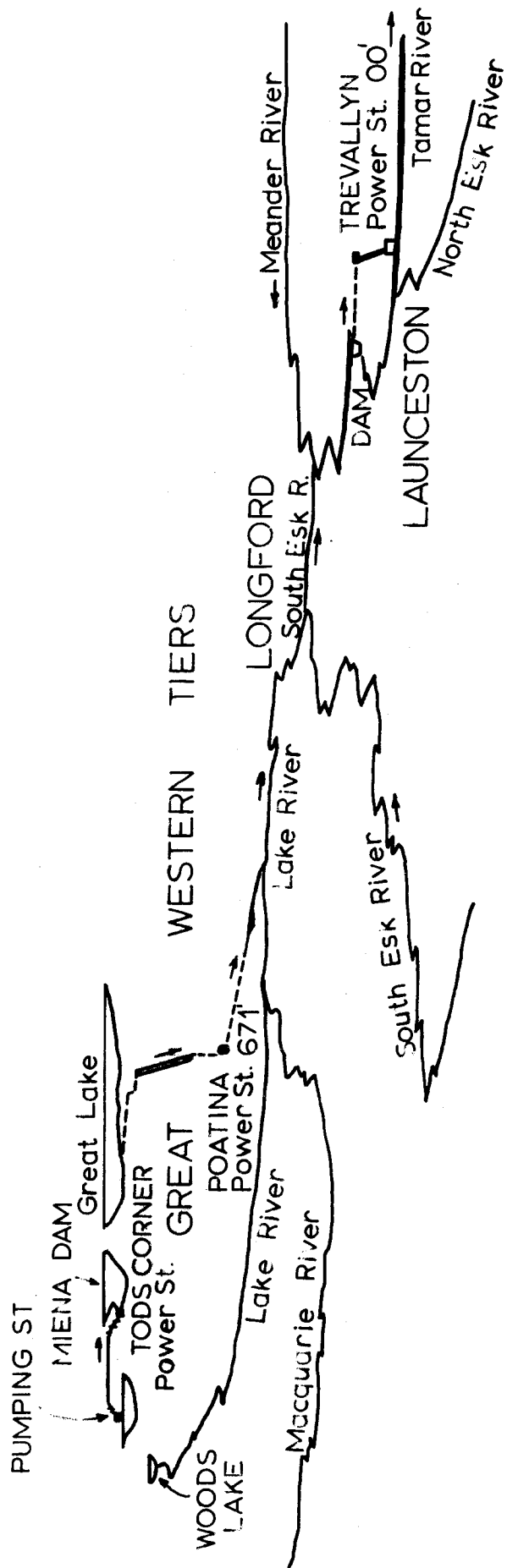

FIG. 16.1 GREAT LAKES SCHEME

Vertical control for the project was provided by a single line of precise levels commencing at existing precise levels at Longford and ending at the Intake Area on the Great Lake.

Aerial photograph control points in this area for large scale mapping, whether pre-marked or by identification, were fixed by bearing and distance radiation from control by tellurometer, chain and theodolite traverse or differential levelling.

Brief mention should be made of some of the specialised tasks carried out to control certain aspects of construction in this area.

For the first time in Australia the "Mole" machine was used for tunnelling. Generally speaking this meant continuous operation over three working shifts in twenty-four hours with surveyors on duty during this time. An illuminated target on the machine was referred to its centre line and observed continually by a theodolite suspended from roof stations, set on grade and azimuth. The direction instructions were relayed from surveyor to machine operator by telephone.

The position of breakthrough of this tunnel had been pre-marked in the underground power station and it is of interest that the machine precisely cut this marking on breakout after some 3 miles of tunnelling.

The power station of this project is 500 ft. underground and permanent access for personnel is provided by a lift shaft. Compartments in the shaft are provided for a lift, stairway and cable ducts. Concrete lining of these compartments was placed by a continuously rising formwork. The progress of this rise was controlled by Wild T2 theodolite fitted with a pentagonal prism observing scales set on the formwork, the theodolite being referred to surface control stations.

In the power station itself the behaviour of the rock during excavation, and subsequently, was studied by two methods of measurement. The differential movements of the lateral walls was recorded by direct measurement with tapes suspended across the station, their absolute movements being measured by the periodic changes in angular directions. Roof movements were checked by precise levelling to suspended tapes.

Although many of these recordings are disjointed due to obstructions and interference during excavation, where it has been

possible to compare results a very good agreement has been obtained, and over a certain period of time the following results can be given for the inward movement of walls:-

	<u>By Angular Method</u>	<u>By Tape Measurement</u>
1)	.002 \pm .0005	.003 \pm .0015
2)	.002 \pm .0005	.003 \pm .0015
3)	.004 \pm .0005	.005 \pm .0015
4)	.003 \pm .0005	.005 \pm .0015
5)	.004 \pm .0005	.006 \pm .0015

Measurements are in feet.

The study and detailed description of many of these specialised tasks could well merit papers in themselves. They are only generally dealt with here.

4. The Gordon River Investigation Area

For investigation purposes this area includes the Gordon River and its tributaries and the upper catchment area of the Huon River. It lies in the South West of Tasmania and is the most isolated and inaccessible area of the State - access can only be gained by air to two recognised landing grounds or by foot on mostly overgrown bushwalkers' tracks.

Although various survey forays had been made prior to 1963, it was not until the summer season of 1963-64 that the area received any concentrated attention. In this season a party of surveyors moved into the area using helicopters for transport and a great deal of valuable work was completed in the form of tellurometer traverses to provide control at three possible dam-sites on the Gordon River and one on the Serpentine River, and height control at various other localities of interest. Concurrently, photo control was established in these areas for future large scale mapping.

By the following summer two of the dam-sites had been selected for detailed investigation and the construction of a road to this area became a probability. A tellurometer traverse was run along the

proposed road route and from this control for aerial photography was established, the eventual strip of large scale mapping being used for preliminary planning and route selection. In this period, also, control was established in the Olga-Hardwood River valley and the Davey River for photography to investigate doubtful hill saddles, to the Scotts Peak Dam-site on the Upper Huon and for a possible road to this area.

During the ensuing summer seasons to the present time control has been placed as needed at new possible dam-sites, storage areas and minor control at sites for terrestrial photogrammetric surveys.

In all these control surveys, control has been established by tellurometer traverse, mixed triangulation and measured lines or resection and measured lines. Computational methods have naturally varied in type with the method of survey. It is known that in this area scale errors do exist in the ruling triangulation; thus all the work completed has been based on provisional co-ordinate values, pending final adjustment and computation.

In the initial stages vertical control was based on the existing trigonometrical heights which were carried through the various traverses and tied to approximate sea level at Port Davey, the closure being 0.3 ft.

The adjustment of this network involved four closed circuits with twelve sections requiring corrections. Maximum correction was 1.0 ft., average correction 0.37 ft. During this time precise levels were being taken into the area based on sea level at Hobart and with the completion of the road into the area the circuit was eventually closed in 1966.

5. Vertical Control

Since the 1930's the Commission has completed about 1,000 miles of third order levelling and since 1955 about 350 miles of first order levelling. This does not include levelling directly associated with construction work, which would probably double the amount of third order. Some of the results attained may be of interest.

Third Order

- 1) Hobart-Granton-Ouse-Derwent Bridge-Miena-Bothwell-Granton (1941/42 - 339 miles).

This was the first major levelling operation undertaken by the H.E.C. and based on M.S.L. Hobart. The purpose of the work was to establish a firm basis for future hydro projects in the Central Highlands and Derwent River Area.

B.M's were placed at approximately 1 mile intervals on prominent trees, culverts, transmission line towers and other permanent structures. The network comprised four circuits, traversing hilly, and in some cases mountainous, terrain.

<u>Circuit</u>	<u>Length</u>	<u>Closing Error</u>	<u>Standard</u>
A	90	-1.05 ft.	.11 \sqrt{M}
B	95	+0.36 ft.	.04 \sqrt{M}
C	100	+0.85 ft.	.08 \sqrt{M}
D	54	+0.60 ft.	.08 \sqrt{M}

Instruments used were -

10" Watts Reversible
Watts Highway
10" Troughton and Simms Dumpy (2).

- 2) Miena-Deloraine-Launceston-Oatlands-Melton Mowbray (1944/45 - 240 miles).

This network comprises two circuits. It was reported that strong winds were encountered on most days and that the best instruments were pre 1914 dumpy levels.

<u>Circuit</u>	<u>Length</u>	<u>Closing Error</u>	<u>Standard</u>
A	160	0.85 ft.	.07 \sqrt{M}
B	80	0.91 ft.	.10 \sqrt{M}

- 3) Derwent Bridge-Queenstown (1950 - 56 miles).
Queenstown-Strahan (1958 - 22 miles).

These two runs extended the 1941/42 Hobart-Derwent Bridge grid to the West Coast closing on MSL at Strahan. The misclose was -0.17 ft., giving a standard of 0.02 \sqrt{M} .

Instruments used were -

Watts Dumpy
Watts Microptic.

4) Queenstown-Burnie (1955/56 - 104 miles).

This extended the Queenstown levels northward along road and railway closing on a Lands and Surveys Department Bench Mark at Burnie. The misclose was 2.05 feet, giving a standard of $0.2\sqrt{M}$ for this section. It is suspected that there is an error in this section.

Instruments used were -

Watts Microptic
Wild N. 2 Reversible

5) Zeehan-Pieman (1958/65 - 30 miles).

This spur line was run along rough tracks closing on approximately MSL in the Pieman River. Misclose was 1.27 ft.

Instruments used were -

Watts Microptic
Zeiss Ni2 Automatic.

6) Mersey-Forth (1951/54 - 153 miles).

This work is based on Lands and Surveys Department Bench Marks at Deloraine and traverses the river valleys in which the Mersey-Forth Power Development is presently being constructed.

<u>Circuit</u>	<u>Length</u>	<u>Closing Error</u>	<u>Standard</u>
A-B	75	0.19 ft.	$0.02\sqrt{M}$
C	43	0.03 ft.	$0.004\sqrt{M}$
D(2)	17	0.19 ft.	$0.045\sqrt{M}$
F	23	0.05 ft.	$0.011\sqrt{M}$

Instrument used - Watts Microptic.

Precise.1) Nive Bridge-Meadowbank-Glenora (1956 - 40 miles).

In July, 1956 precise levelling was commenced at B.M. 71 (on old 1941 third order grid) Nive Bridge, traversing down the Derwent River as far as Meadowbank for the purpose of controlling

subsequent Lower Derwent Schemes.

The level of B.M. 71 of 776.80 (old 1941 level grid) was accepted and all Lower Derwent work based on this value.

In July, 1963 a connection was made to the 1966 Hobart-Lake Pedder-Maydena-Hobart precise circuit. There was a discrepancy of 1.752 ft. From this it appears that the old value of B.M. 71 is 1.752 ft. too low.

Instruments used were -

Kern NK3 with parallel plate
Zeiss Ni2 with parallel plate.

2) Longford-Great Lake (1958 - 30 miles).

In February, 1958 a precise run was commenced to take levels from Lands and Surveys Department B.M. L109 at Longford through the site of the Poatina Scheme to the Great Lake, a distance of 33 miles. A connection to B.M. 927 Great Lake gave the following comparison:

B.M. 927 = 3388.40 based on Miena (1941 Hobart-Miena run)
 3388.07 based on precise run from Longford
 0.33

A limited discrepancy of $0.017 \sqrt{M}$ between forward and backward runs was observed and progressive partial divergences amounted to -0.0026 ft. at B.M. 927. By Lallemand's formulae

$$\eta_r = \pm .0021 \text{ per } \sqrt{M}$$

$$\sigma_r = \pm .0020 \text{ per mile.}$$

Instruments used were -

Kern NK3 with parallel plate
Zeiss Ni2 Automatic with parallel plate.

3) Turners Beach-Ulverstone-Howells Plains (1959 - 70 miles).

In July, 1959 precise levelling was commenced, traversing through the sites comprising the new Mersey-Forth Scheme.

CONTROL FOR MAPPING

A connection made to SPM 3479 gave the following comparison:

$$\begin{array}{r} \text{SPM 3479} = 1585.04 \text{ based on Deloraine (1944 run)} \\ \underline{1584.87 \text{ Precise}} \\ 0.17 \end{array}$$

Again, a limiting discrepancy of $0.017 \sqrt{M}$ between forward and backward levelling was observed and progressive partial divergences amounted to 0.0511 ft. at SPM 3479.

$$\eta_r = \pm .0017 \text{ per } \sqrt{M} \quad \sigma_r = \pm .0018 \text{ per mile.}$$

Instrument used was Zeiss Ni2 with parallel plate.

4) Hobart-Huon-Lake Pedder-Maydena-Hobart (1960/66 - 202 miles).

A section of approximately 7 miles at Arthurs Plains is classed as $0.035 \sqrt{M}$. To the North West of Lake Pedder the line traverses the Serpentine Valley on its eastern side. The valley floor is an area of peat overlaying quartzite gravels supporting button grass and mixed scrub, the whole area being most unstable for levelling operations. In the main, the line was confined to the eastern slopes on firm ground but in several cases the tributary valleys had to be spanned, spans of up to one mile being encountered.

In these cases reciprocal levelling was employed. Two adjustable targets were designed to be fitted to the level staves, the whole set up being rigidly supported. The targets were moved by radio instruction from the observers and simultaneous observations taken. This section is classed as $.05 \sqrt{M}$. The remaining 185 miles satisfies the $.017 \sqrt{M}$ specification.

Misclose of circuit at McPartlan Pass $0.107 \text{ ft.} = .0075 \sqrt{M}$ over 202 miles.

$$\eta_r = \pm .0018 \text{ per } \sqrt{M} \quad \sigma_r = \pm .0014 \text{ per mile.}$$

Comparison of levels with existing trigonometrical heighting:

	<u>Level</u>	<u>Trig.</u>
At McPartlan Pass B.M.4157	1111.969	1113.0
At Middle Gordon B.M.4162	1402.728	1403.9

Instrument used was Zeiss Ni2 with parallel plate.

It is worthwhile noting that where precise runs traversed the same routes as the original third order runs, Reduced levels of common points are in good agreement. There are discrepancies of course, but one conclusion that can be drawn is that when economics and the impermanence of B.M's are considered, a network of second order ($0.035 \sqrt{M}$) levels would suffice throughout the State. Precise levels are only required in limited areas and generally between only a few structures.

During the last decade certain problems have arisen and brief mention of them is appropriate.

- (1) Horizontal obliquity is present in certain automatic levels - unless this is realised and the necessary field procedure followed, it is well-nigh impossible to obtain satisfactory agreements in precise work.
- (2) Possible large differences in the co-efficient of expansion of pairs of invar staves should be watched. This can have adverse effects on results when steep slopes are being traversed.
- (3) Temperature does not seem to affect automatic levels to any degree. Careful factory adjustment of compensators is of paramount importance however.
- (4) It is a well known fact that the automatic level saves considerable time. However, compensation systems do fail at the most unexpected times. For this reason one must be constantly on guard against malfunction. On construction work there is still a lot to be said for the "reversible" bubble type instrument. In order that maximum precautions are taken in all phases of precise work instructions are issued to all surveyors prior to commencement of work.*

* These instructions formed an Appendix to the original paper. For reasons of space this is omitted.

Adjustment.

Rigid adjustment methods have not been used. A simple proportional adjustment is usually used on third order work and the small misclosures of precise work, coupled with the impermanence of Bench Marks, makes anything but simple adjustments academic for our work.

6. Photogrammetric Control

The Hydro-Electric Commission, being an engineering organisation, is mainly concerned with large scale mapping covering only limited areas. It has therefore been unnecessary to apply the practice of block adjustment. However, strip adjustment is frequently used and it is intended here to describe briefly methods currently in use, together with the programmes developed for use in the Elliot 503 Computer.

Over the last nine years 473 aerial models have been plotted and some 461 drawings issued covering approximately 600 sq. miles.

Methods of Adjustment used and Programmes developed. Depending on the density and nature of control layout, there are three types of adjustment used, namely, linear for short strips and interpolation to second or third order for longer strips.

When the number of models in the triangulated strip is small (up to six models), the adjustment is effected by the following formula:-

$$dX, dY, dZ = a_0 + a_1x + a_2y + a_3xy \quad 1.$$

For second and third order adjustment the following formulae are used respectively:-

$$dX, dY, dZ = a_0 + a_1x + a_2y + a_3xy + a_4x^2 \quad 2.$$

$$dX, dY, dZ = a_0 + a_1x + a_2y + a_3xy + a_4x^2 + a_5x^3 \quad 3.$$

When only planimetric co-ordinates are required in a short strip, the adjustment is sometimes performed utilising Affine transformation, giving practically identical results to those using formula 1.

Computer programmes for the above methods of adjustment were developed early in 1965. Generally they all follow similar lines. Firstly, the transformation constants are derived using the control points in the first model to transform machine co-ordinates into the geodetic mm system. Then the differences between the transformed machine mm co-ordinates and the geodetic mm co-ordinates are derived for all control points in the strip. (The differences in height are derived by subtracting machine mm values from geodetic mm values.) These discrepancies (dX , dY , dZ) constitute the absolute terms for the observation equations to be formed by the above formulae, 1., 2. or 3. Then the normal equations are formed and solved, yielding the co-efficients required to compute respective corrections for any point in the triangulated strip.

On the print-up the following values are shown:-

- 1) Co-ordinate origin in ft.
- 2) Transformation constants.
- 3) Point number and the corresponding transformation residuals (vX , vY) for all points used in the transformation.
- 4) Point number and the corresponding differences to be adjusted (dX , dY , dZ) for all control points used to adjust the strip.
- 5) Point number, East and North co-ordinate and height for all adjusted points (in ft.).

By inspecting the transformation residuals and the differences to be adjusted, it is easy to assess the quality of the absolute orientation in the first model, as well as to form an opinion as to whether the respective error surface has been formed in an acceptable manner.

With the arrival of the Wild EK5 Co-ordinate Recorder in August, 1966 all photogrammetric programmes had to be modified. It was decided to make as full use as possible of the A7-EK5-Flexowriter combination.

A procedure "Sort" was written and included in the existing programmes after some modifications to them.

With this arrangement, any manual processing of the recorded data has been excluded. Machine co-ordinates for points in the strip (control and giveout) can be recorded in any mixed order. The programme sorts and separates control points from giveout points and rearranges the two groups accordingly. For points read twice, the mean value is calculated and this mean value is used in all further computations. The computer processing time for a strip consisting of some twenty models is approximately two minutes and there is no extra data preparation time required besides the normal observing and recording time by the A7-EK5 combination.

Accuracy Attained. A strip flown in the Lake River area was selected to test and analyse accuracy of results with this type of adjustment. Flown with the RC5 Film Camera, focal length 115 mm, at an altitude of 10,000 ft. above mean ground level, the run consisted of 19 models and the length was some twenty miles. The evaluation was performed in an A7 Autograph. This particular strip was chosen due to the control layout and also because redundant control for checking purposes was available.

Control on this run was situated at the beginning of the strip (five points, position and level), one-third way along the strip (four points, position and level), halfway (four points, position and level), two-thirds along (four points, position and level), and at the end of the strip (four points, position and level). Twenty-two control points, not used in the adjustment, with fixed horizontal and vertical co-ordinates, were available in this run and these were used to check the accuracy attained when adjusting the strip to second as well as third order polynomials. Results are summarised in Table I.

It should be mentioned here that the triangulation of this strip was performed in the A7 Autograph early in 1960 and some difficulties were experienced with photo control point identification. Consequently, this could have had some adverse effect on the final results.

Recently a test strip was flown at an altitude of 5,000 ft. above mean ground level and some preliminary work has been done to control this run. It is intended to carry out more elaborate tests pertaining to aerial triangulation on this strip at that particular altitude in an effort to determine the minimum amount of control required to perform transmission line surveys by photogrammetric methods. Here the

accuracy requirements are rigid, the maximum allowable difference in height being ± 2 ft.

TABLE I

Results of analysis of strip adjustment

A. Adjustment using second order function.

	dE	dN	dL	dH
Mean square errors (feet)	± 1.4	± 2.4	± 3.1	± 1.6
Max. values (feet)	+4.9	+6.1	+6.3	-4.4
Mean square errors (at contact scale, 1/26500, in microns)	± 16	± 28	± 36	± 18
Max. values (at contact scale, 1/26500, in microns)	+56	+70	+73	-51

B. Adjustment using third order function.

Mean square errors (feet)	± 1.4	± 2.0	± 2.8	± 1.5
Max. values (feet)	-4.6	+4.3	± 4.9	+4.4
Mean square errors (at contact scale, 1/26500, in microns)	± 16	± 23	± 32	± 17
Max. values (at contact scale, 1/26500, in microns)	-53	+49	+56	-51

7. The Gordon Road

In 1963 the decision was made to construct a road from Maydena to the junction of the Gordon and Serpentine Rivers. This road, over 50 miles in length, was to pass through some of the most rugged terrain in Tasmania.

Due to the nature of the terrain and the short time available for location and design, maximum use of photogrammetric methods seemed to be the only feasible means of providing the necessary survey

information for reconnaissance and design

For the general road location, maps at a scale of 400 ft. = 1 inch with a 10 ft. contour interval were requested and for design 100 ft. = 1 inch with 5 ft. contours. Spot heights were also required at 50 ft. intervals along the proposed centre line wherever possible.

Strips of photographs were flown along the approximately located centre line. This route was selected from 1 ml. = 1 inch maps with 50 ft. contours produced by the Lands and Surveys Department.

Specifications for photography were as follows:-

Wild RC8 Camera	115 mm Lens	80 ^o /o Overlap	10,000 ft. above ground
--------------------	-------------	----------------------------	----------------------------

Both the 400 ft. = 1 inch and 100 ft. = 1 inch series of plans were to be produced from this photography. Consequently the photo control had to be as strong as possible - five points per model wherever practicable. The centre point was normally fixed only vertically in order that model deformation could be checked.

On examination of the photo strips it became apparent that for some 25 miles the road was to go through densely timbered areas and there was no possibility of producing the 100 ft. = 1 inch maps to design requirements.

Photo control points were fixed by tellurometer. Several detail points were surveyed at each point in order to avoid misidentification. The only means of access to these points was by helicopter.

For some five miles North of Mt. Wedge the timber was so dense that no photo control could be established. Aerial triangulation was used to bridge this area, using selected tree-tops as giveout points. Tree height in this area was up to 200 ft. A polaroid camera adapted to photograph through the eyepiece of the Autograph was used to record these giveout points. 400 ft. = 1 inch maps showing 50 ft. form lines were produced for this area. Although lacking in vertical accuracy they did present a reasonable picture of the terrain and were invaluable in deciding on the approximate centre line.

The 400 ft. = 1 inch series was drawn first and then without removing the plates from the Autograph the road centre line was selected

and marked by Design engineers. A strip 300 ft. wide on either side of the centre was then plotted at 100 ft. = 1 inch with 5 ft. contours. When a 100 ft. = 1 inch sheet was completed it was forwarded to Design engineers for selection of the final road centre line. Plotting of the next 100 ft. = 1 inch sheet proceeded immediately.

Finally, construction drawings were issued from these 100 ft. = 1 inch photogrammetric plots. Some 18 miles of road was designed in this manner.

8. King-Franklin Investigation Area

Large scale maps are often requested for some remote areas. To provide the appropriate photo control in such areas would, in some instances, increase the time and the costs beyond acceptable limits. In such circumstances the only practical solution is to compromise by lowering the accuracy specifications.

As an example, after selection of the King-Franklin project, the objective was the investigation of alternative sites for a high dam.

In the area of interest, the Franklin River flows through a gorge approximately 1,500 ft. deep, the sides of the gorge being densely timbered. Maps at a scale of 100 ft. = 1 inch were requested for this project, showing 10 ft. contours. In order to complete the work in one season the only possible access to this area was by helicopter. Even then landings were generally limited to areas well outside the gorge.

To supply the necessary contour information for the dam location a strip of some 4 miles would have to be plotted at the above-mentioned scale. The dam location could not be pinpointed any closer because suitable maps were not available. Due to the nature of the terrain and timber coverage the plotting had to be done from normal angle photography and at a flying altitude of 4,500 ft. above ground level, some 15 models being required. The effort and cost involved to provide photo control for the strip did not make this a practical proposition and on the other hand triangulation at that altitude with normal angle photography could present problems in relative orientation, particularly when critical surfaces are considered. Consequently, a different approach was adopted.

A strip of photographs was flown over the general area at 10,000 ft. above ground with the RC8 Camera using a wide angle lens, together with two strips flown at an altitude of 4,500 ft. above ground with the normal angle lens. These two strips were placed in position to cover the areas required to be mapped. Four models from the high flight were enough to cover the area involved and these were rigidly controlled. This did not present a serious problem because outside the gorge the timber tends to become scattered and suitable landing places could be selected for the helicopter.

The photo points, at which several detail points were surveyed, were fixed by tellurometer. In the gorge height control was provided along the river by spirit levelling for the model centre points.

Commencing at the southern end of the run, the first of the high flight models was set up and a plan was drawn at 400 ft.= 1 inch with 50 ft. contours. At this stage the engineer concerned with the project was called in to select likely damsite locations in this area. Details identifiable on both runs were then selected in their appropriate positions to serve as control on the low flight and their machine co-ordinates were recorded.

Proceeding in this manner, some 50⁰/o of the models on the low run were eliminated and did not receive any further consideration.

Finally, the requested 100 ft.=1 inch plans with 10 ft. contours were produced from the low flight photography using control obtained from the higher flight.

9. Terrestrial Photogrammetry

At present approximately 50⁰/o of all photogrammetric plotting done by the H.E.C. is from terrestrial photography taken with the Wild photo-theodolite or the C12 Stereometric Camera. Some 700 terrestrial models have been plotted during the last 9 years, producing plans at scales ranging from 400 ft.= 1 inch to 4 ft.= 1 inch. For close-up photography such as inside tunnels, power station cuts etc., the C12 Stereometric Camera has proved invaluable.

The normal control requirements for terrestrial plotting are three points per model, one point situated in the central foreground,

two points in the background on either side of the model. This control arrangement allows for elimination of model deformations caused by errors in base length, convergence etc.

Sometimes control is transferred from one model to another by selecting detail points identifiable on both models. This practice is quite sound as long as the giveout points selected are situated within the controlled area.

The field control points for terrestrial plotting are normally fixed by intersection for position and by vertical angle for height, the base being measured by steel band or subtense bar.

Unorthodox Photogrammetric Practice. Some examples are briefly outlined below:-

- (1) The calculation of volume and weight of rocks comprising the rip-rap (protective layer) on the face of rockfill dams by utilising terrestrial photography taken with the photo-theodolite. Only horizontal model control is required here in order to obtain the required model scale. (The difference in elevation of the two base stations must be known.)

The machine co-ordinates are recorded by the EK5 on tape and processed in the Elliot 503 Computer, yielding the volume and weight for the individual rocks.

- (2) The determination of tunnel cross-sectional areas at close intervals to estimate the hydraulic roughness in the unlined tunnel and assess the merits of lining the tunnel with concrete.

The photographs are taken with the C12 Stereometric Camera and each individual model, covering 20 cross-sections, must be rigidly controlled so that the correct area of every section can be determined. The model is scaled in the A7 Autograph, treating the photographs as being affine distorted in "y" direction. The double focal length of the C12 cameras are set in the autograph and the ratio for the "y" movement halved. (The calibrated focal length of the C12 cameras are 92.21 and 92.20 respectively.) When the

correct orientation has been accomplished the autograph is disconnected from the plotting table and controls are switched over to aerial and machine co-ordinates are recorded on tape at each section in a manner to allow for accurate area computation in the computer.

- (3) The use of the photo-theodolite camera to obtain vertical photography of Meadowbank Dam site benches for geological purposes. The photographs were taken from a flying fox, the camera being held in a specially designed framework and levelled by a bubble attached to the back of the camera. During photography the camera was positioned from predetermined ground stations with the aid of a theodolite.

Before the photography the benches were covered with a grid of white paint marks $3/4$ " in diameter to serve as premarked control. Nine exposures were made, constituting six stereo models. The camera heights varied from 60 to 100 ft. above ground.

The models were set up as conventional aerial photographs and plotted at a scale of 5 ft. = 1 inch with 6 inch contours, showing all identifiable geological details such as faults, rock boundaries etc.

Acknowledgement. This paper is presented with the permission of the Commissioner, Hydro-Electric Commission, Tasmania, Mr. A.W. Knight, C.M.G., M.E., B.Sc., B.Com.

DISCUSSION ON PAPERS NO. 15 AND 16.

Chairman: Mr. S. Bervoets, University of Melbourne.

J.G. FREISLICH: Have you used Tellurometer in tunnels in Tasmania, and if so what is the accuracy of the results obtained?

J.W.S. LINTON: We used the Tellurometer for determining the position of a bend in Lemonthyme Tunnel, which is about 4 miles long. The distances measured were 13,000 and 15,000 feet and the precision was quite good.

D.M. JENKINS: The ground swing and reflections were no worse and may have been better than outside, on the surface, and the chief trouble was humidity which in some instances reached 100%.

G.G. BENNETT: Did you find that the ground swing behaved in a cyclic manner, or was only a partial ground swing curve developed?

JENKINS: It appeared that only a partial ground swing curve was obtained. The error from this source did not worry us, as the purpose of the measurement was to obtain a gross check on chaining.

L.A. WHITE: Were measurements made in any tunnels of varying geological nature and was the type of rock ever observed to affect the observations to different degrees?

JENKINS: The observations were made only through a homogeneous type of rock, a schist.

H. KIRSCH: Is there any reason to believe that the tellurometer distances being large is due to multiple reflections on tunnel walls, the direct signal being weaker than the total number of reflections

and the length of the path of reflected waves being larger than the direct distance. The tellurometer results in tunnels show all corrections having positive sign. Does this not indicate that the measurement is in fact a reflected ray?

J.W.S. LINTON: This problem hasn't been investigated sufficiently at this stage. We were satisfied that the results obtained were within the required precision.

H. KIRSCH: The tellurometer measurements are, with one exception, longer than chained distances and this may be due to the confined space in tunnels, multiple reflections on walls and lagging of the electro-magnetic wave front. The subject has been treated before in a paper by Nottarp, Allgemeine Vermessungsnachrichten, May 1962 and others in the same periodical. If the electro-magnetic wave front moves closely along the boundary of two media whose dielectric and permeability constants are different (rock-air) the wave front is deformed. The closer the wave group is to the boundary the more retarded is its velocity. As the velocity of the electromagnetic wave is deemed to depend only on μ , ϵ and c but not on close proximity to a boundary the travelling time appears longer which in turn causes an apparent longer path.

The result of Nottarp's investigations is that distances are measured longer by 1 to 6 cm. in close proximity as against distances of about 5m. away from the boundary. In tunnels of about 12ft. diameter the wave front is hindered not only along the ground but practically on all sides.

A further possibility is calibration error of measuring tapes which of course is involved as well in a comparison of results, and as well the constant term of ± 2 inches of the error formula of tellurometer measurements.

We in the Snowy organization have not measured tellurometer distances in tunnels. The old MRA1 was not good enough and when we obtained a MRA3 late last year our tape measurements in tunnels were so perfected that we did 3 miles of double measurement in an 8 hour shift on Sunday without interfering with maintenance work. And as

the last tunnel of the Snowy system was holed through recently there will be no further opportunity to check for the effect mentioned above. (Later written contribution).

P.V. ANGUS-LEPPAN: A comprehensive study of electronic and electro-optical distance measurements underground in Canada has shown that the accuracy is not diminished appreciably by the tunnel reflections and other circumstances.

G.G. BENNETT: Improvements may come with the use of MRA4 with its shorter wave length.

J.W.S. LINTON: We have already achieved the precision we require in measuring underground distances with tellurometers.

J.E. MITCHELL: What type of exposure device - lens hood or shutter - is used on the photo-theodolite cameras in operations by the State Electricity Commission of Tasmania and by the Snowy Mountains Hydro-Electric Authority.

LINTON: The Wild photo-theodolite is equipped with a Compur Rapid Shutter, (stops from 1/50 sec. to 1 second) and timing device for longer exposures.

W.A.G. MUELLER: The photo-theodolite is equipped with lens cap only; it is manually operated. Generally exposure times are 10 - 20 seconds in shade and 2 seconds in sunlight.

A.G. BOMFORD: Why do the diagrams not show any of the modern State Tellurometer Traverses, but the old triangulation? Don't you trust tellurometer measurements?

1.A. Chrzanowski and P. Wilson. Underground measurements with the Tellurometer. Canadian Surveyor, v. XX, 2, p. 107, June 1966.

2. These are not included in this volume.

LINTON: The diagrams represent the State Triangulation net which existed at the time of our entry into these areas. At times both Lands Department and Hydro-Electric Commission carried out the work concurrently.

H. KIRSCH: With reference to LINTON's remark on Photogrammetric Control in Gordon River Area have photogrammetric control points or other points, co-ordinated on photographs, been used for tie in, or setting out purposes as road traverses etc. (after transformation of XYZ co-ordinates into E.N., R.L. co-ordinates)?

LINTON: No. About 30% of control points have been fixed by bridging and other photogrammetric procedures.

MITCHELL: Are the map sheet boundaries, meridians and parallels or grid lines? Do they correspond to the national mapping boundaries?

LINTON: They are grid boundaries, and each sheet corresponds to one of the standard national mapping sheet lines.

A.P.H. WERNER: I wish to direct the question to Mueller. Why was the subtense bar and not steel tape mentioned as standard photogrammetric field equipment?

MUELLER: Simply because I was more conversant with the subtense bar.

S. BERVOETS: Do you work on co-ordinates for your design in the Tasmanian H.E.C?

LINTON: Co-ordinates are used throughout. Engineers design the structure and give us the co-ordinates of points to be marked.

BENNETT: The question is directed to MUELLER. Was the marking of the subdivisions in the Talbingo area intended for use in the preparation of a plan of subdivision for submission to the Registrar General? And what are the savings, if any, using photogrammetric methods on subdivisions?

MUELLER: The idea was not to replace the property survey by photogrammetry, but to set out the centre line of each road. The cadastral survey followed in the normal way. The relative accuracy of features is much higher if the centre line was set using the points identifiable on the photographs.

I. POWELL: Were all photo control points levelled and if not, were they sufficiently accurate to lay out kerb lines etc.

MUELLER: The targets were set out prior to photogrammetric operation. They were levelled afterwards and the discrepancy between photogrammetric heights from model and the same obtained from levelling was - 2 inches.

J.K. BARRIE: Photo images may be more economical than photo target points for large scale photogrammetric surveys unless you have your own plane and camera. The maintenance of targets is difficult.

W.B.R. SMITH: It may be of interest to note that the use of pre-targetted control and of good control surveys is becoming increasingly accepted by the N.S.W. Department of Main Roads. For major structures, such as expressways, the use of a fully co-ordinated system of control for setting out purposes saves much time and justifies the expenditure for provision of targets and control surveys. It is futile to set out road centre line, for the first thing the construction organization does is to destroy all marks there. It is thus the tops of cuttings and the toes of fillings which should be set out first, with the actual centre lines being of interest only as the completion of construction is approached. With the growth of confidence from engineers and designers, the trend towards use of co-ordinates for defining structures and cadastral boundaries is positive.

PHOTOGRAMMETRIC PLANIMETRIC ADJUSTMENT

by

D.R. Hocking

Abstract: This paper describes improvements to the slotted template method of radial triangulation. Results are given of slotted template tests using the Canberra photogrammetric test block. A suggested procedure is outlined for obtaining block adjustment information for larger scale mapping when using an automated stereoplotting system.

1. Introduction

Graphical, slotted template and numerical radial triangulation methods are well known and have been used for many years to increase the density of horizontal control for mapping from aerial photographs. (1) The slotted template method is particularly suitable for intensifying control for rapid planimetric mapping.

Within the Division of National Mapping slotted template assemblies have been completed for over two hundred 1:250,000 map areas in Australia covering nearly 1.25 million square miles and for about two hundred and thirty 1:50,000 map areas in Papua - New Guinea covering approximately 41,000 square miles.

Where possible, templates have been assembled in large blocks and laid to the next line of control outside the area to be mapped, in order to obtain the best position from the ground control available.

Annexure 'A' gives examples of two large template assemblies; one covers 88,000 square miles (about the area of Victoria) in the semi-desert region of central Australia and the other about 20,000 square miles of generally mountainous country extending from sea level to over 11,000 feet in Papua - New Guinea.

Over the years many refinements have been introduced and it may be of interest to describe the more important developments in techniques and equipment leading to improved accuracy of the horizontal control for mapping using slotted template radial triangulation.

These developments have resulted in the control intensification procedure to be described, which is aimed at the rapid production of the 1:100,000 scale Australian map series with 20 metre contours from 25,000 ft. RC9 photography. The vertical control is obtained from Airborne Profile Recorder (APR) profiles along the middle of the side lap between runs of mapping photographs so that no extensive aerial triangulation for heights is required.

2. Slotted Templates - General

The main steps between receiving the photographs and control, and passing the map base sheets to the stereoplotter operators for plotting detail are:-

1. Preparation of the photogrammetric work diagrams.
2. Obtaining diapositives.
3. Marking ground control, radial centres and tie points and transferring these points to adjacent diapositives.
4. Preparation of slotted templates.
5. Preparation of map base sheets.
6. Template assembly.
7. Pricking through template positions and identifying these on the map base sheets.

3. Procedure in More Detail

Photogrammetric Work Diagrams. The preparation of these diagrams is of the utmost importance in the systematic planning and execution of the photogrammetric work, particularly when a large block is being mapped.

The ground control, aerial photography flight lines and photocentres are plotted on overlays to the 1:250,000 maps. Photo coverage usually consists of 8 east-west runs with RC9 camera taken at 25,000 feet with 80° forward and 25° side lap, giving about 190 models per 1:250,000 map area. The best selection of models is made so that the photocentres of adjoining runs are as near as possible in line north-south. In addition, sufficient of the 35mm. APR profile positioning photocentres are plotted on the diagram to show the profile in relation to the side lap between runs of mapping photos.

Diapositives. Stable base film diapositives .004 inches thick compensated for lens distortion, earth curvature and atmospheric refraction for 7,000 metre flying height, are produced using the U4A printer. The diapositives can be printed with either a cross or a dot and circle at the photocentre. The 0.1mm. dot with a 4mm. dia. circle is preferred for more accurate point transfer.

Point Selection, Marking and Transfer. The ground control is transferred from the 1:30,000 scale spot photography to the 1:80,000 scale mapping photography using a Bausch and Lomb Zoom 95 stereoscope. Vertical control is selected along the APR profile and if this is close to the centre of the common overlap then it may be used as both tie point and vertical control point. Otherwise a separate tie point is selected. In the case of badly tilted photos of rugged country, by levelling the model to APR profile heights, the nadir may be found and used as the radial centre. Point selection and transfer are done stereoscopically using Wild mirror stereoscopes with 8X binoculars cantilevered over the diapositives on a light table. Points are marked using a hand-held needle or scribe point.

Preparation of Slotted Templates. The template material is "Flovic", a white opaque P.V.C. plastic .015 inches thick which is stiff, smooth, cheap, cuts cleanly and is not seriously electrostatic. Template blanks are cut about 10 inches square with a 4mm. diameter hole near the centre. A control stud (see Template Assembly paragraph) is put in

this hole. Then on a light table, which has a hole in it to take the control stud shank, the radial centre on the diapositive is placed over the centre of the small circle on the base of the perspex insert in the control stud and the position of points on the diapositives pricked through to the template. See Figure 17.1

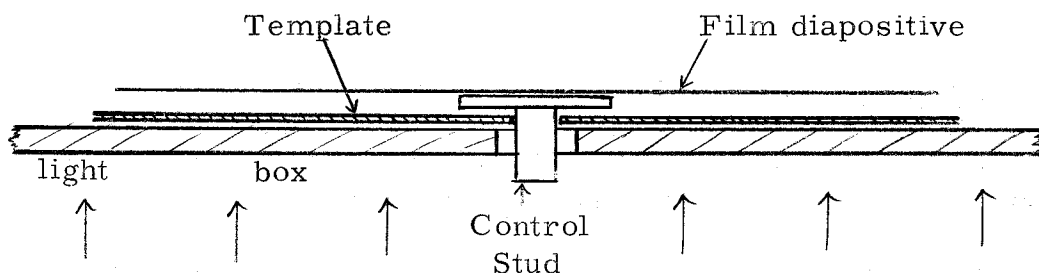

Figure 17.1

The templates are slotted on a machine designed by S.R. Skinner, Melbourne, in conjunction with the Division. (See Annexure 'B') Accurate templates are produced quickly on this machine, which is comfortable to operate and is much cheaper than the imported product. An interesting design feature is the fixed angle of 10 degrees between the template radial direction and the machine (slot) radial direction with the point on the template being positioned between a double line on the base of the perspex cursor. In addition, the table can be displaced parallel to the slot radial enabling templates to be easily and accurately slotted at a different scale without any need for radial lines to be drawn on the template.

Two cursors are available which provide overlapping ranges of radial distances as follows:-

- Normal cursor - 1cm. to 35cm.
- Long cursor - 31cm. to 65cm.

The slot is 4mm. wide and normally 50mm. long. However, a much longer slot can be cut by moving the table carrying the template and extending the slot to accommodate large radial displacements.

Preparation of the Map Base Sheets. Stable drafting film, "Ozatex" .003 inches thick, is used for the base sheets on which the sheet corners, graticule, grid and ground control points are plotted at 1:100,000 scale using a Wild Co-ordinatograph.

A 4mm. diameter hole is punched at each map sheet corner to take a register stud and then the base sheets are laid out in one block. The exposed edges of the overlapping sheets are covered with tape to avoid any sharp edges on which the studs could lock during the template assembly. The masonite floor on which the assembly is laid is 32 ft. x 22 ft. and painted gloss white.

Template Assembly. As previously mentioned the slot width in the template is 4mm. Some tolerance between the stud and slot is necessary before any adjustment can be made. The amount of tolerance depends mainly on photo tilts, terrain slopes and accuracy of point marking.

While a stud diameter of 3.85mm. giving a tolerance of 0.15mm. may be used in a template assembly prepared from air-dried paper prints of a mountainous area in New Guinea, it is possible to reduce this tolerance when using the procedures described for slotted template triangulation in the relatively flat areas of Australia.

A stud diameter of 3.97mm. was selected and two types of studs are used:-

1. Control stud, a brass with a 0.8mm. diameter circle engraved on the base of a perspex insert.
2. Movable studs, brass with a 2mm. diameter hole concentric with the shank to take the pricking needle.

The control stud is a smaller edition of one which has a shank diameter of 0.25 inch and is used by the United States Geological Survey for stereo-template assemblies. Control studs are accurately positioned with the circle on the stud base concentric with the plotted ground control point, and securely taped to the base sheet.

Templates are then laid out between the control, run by run, with frequent tapping of the templates to obtain the best adjustment. The assembly is considered complete when all the templates are laid to the control and the entire assembly is free of buckles with all stud bases flat on the base sheets. Spring wire clips are placed on the studs and pushed down to lock the assembly prior to pricking through the template positions to the base sheets which is done systematically, run by run, to avoid missing any points.

It is not necessary to prick through the radial centre as it is the practice within the Division to show the photocentre on the manuscript map so that other agencies may add additional information, for example, geophysical data by radial methods. The photocentre can be added to the manuscript map at the detail plotting stage when the diapositives are in the stereoplotter.

As the templates are lifted, the pricked points are labelled and circled freehand on the base sheets which after being inked up are then passed to the Wild B8 or Kern PG2 instrument operators for topographic detail plotting.

Accuracy of Slotted Template Triangulation. Tests of the improved slotted template method have been made using the Canberra Photogrammetric Test Block consisting of 4 runs of 8 models of Wild RC9 photography with a 10,000 ft. flying height above ground. This gives a block of 32 models at 1:35,000 approximate photo scale compared with the 32 (usually) models at 1:80,000 approximate photo scale for a 1:100,000 map area.

Survey stations with photo identified ground control points have been established at all 45 model corners.

The 1959 RC9 photography which was the first to be flown in Australia is on pyro developed Super XX film and the quality is obviously below present day standards.

The flying is good and the photo tilts in grads are:-

Omega Maximum = 1.56 mean 0.56
Phi Maximum = 0.96 mean 0.45

The control distribution for the tests was as follows:-

- 4 controls, one at each corner of the block.
- 5 controls as above plus one in the centre.
- 9 controls as above plus four, each one midway between the corner control.
- 16 controls full perimeter control less alternate model corners on Runs 1 and 4.

The residuals are at the triangulation scale of 1:40,000 (photo scale is 1:35,000 approx.) and were obtained by comparing the template position read on the co-ordinatograph against the ground control co-ordinates.

Brief Description

	<u>Fixed</u> <u>Control</u>	<u>Check</u> <u>Control</u>	<u>m. s. e.</u> <u>in mm.</u>
Slotted template triangulation	4	40	⁺ .16
from hand marked points on	4	40	.18
film diapositives with photo-	4	40	.18
centre as radial centre.	5	39	.15
	9	16	.12
	16	28	.09
Same set of diapositives as	4	41	.18
above but with the nadir as	4	41	.24
the radial centre.	5	40	.16
	9	36	.11
	16	29	.08

The results tabulated are the most recent and include the maximum number of check control points. It is significant that with a tolerance of 30μ between stud and slot both sets of templates, nadir and photocentre, lay flat to the full model (45) control points.

Earlier test results, from three different sets of slotted templates using a point near the nadir as the radial centre gave an average m. s. e. for eight assemblies of ⁺0.19mm. when held to the 4 corner control points and using 32 check controls.

It is worth noting that the test block is a neat area, i. e., no 'overspill' of models is available. Experience with template assemblies and a recent paper by Ackermann (2) shows that improved planimetric accuracy can be expected when the photogrammetric block is extended beyond the neat line joining control points.

In the tests the average m. s. e. in position from templates laid to 4 control points is less than ⁺0.2mm. and it is expected that this

figure would be improved using stable base film photography and extending the block adjustment to the next line of control.

Production results are, usually, not quite as good as test results. However, if the work is carefully done using the procedures described then a m. s. e. not greater than $\pm 0.25\text{mm}$. is anticipated in production. This would allow an adequate margin for the scaling-in error and plotting error thereby meeting the National Mapping Council, Standards of Map Accuracy, which require a m. s. e. in position not greater than $\pm 0.3\text{mm}$.

4. Future Developments - Automated Plotters

The Division expects delivery of a B8 - Stereomat Automated Plotter later in 1967 and the arrival of this instrument is awaited with keen interest. A provisional flow diagram covering the map control segment of the system is attached as Annexure C.

The main idea is to carry out the absolute orientation by levelling to APR heights and scaling in to slotted template positions. Then, after scanning the model for the orthophoto and contour image data the model co-ordinates would be recorded and stored for future block adjustment for larger scale mapping when required.

References.

- (1) I.T.C. Textbook of Photogrammetry. Vol. III, Chapter 111.2. Radial Triangulation. Delft.
- (2) F. Ackermann. On the Theoretical Accuracy of Planimetric Block Triangulation. International Symposium of Spatial Aero-triangulation 1966, University of Illinois.

PROVISIONAL WORK FLOW DIAGRAM FOR STEREO
COMPILATION USING B8-STEREOMAT AND DIGITAL
RECORDING EQUIPMENT.

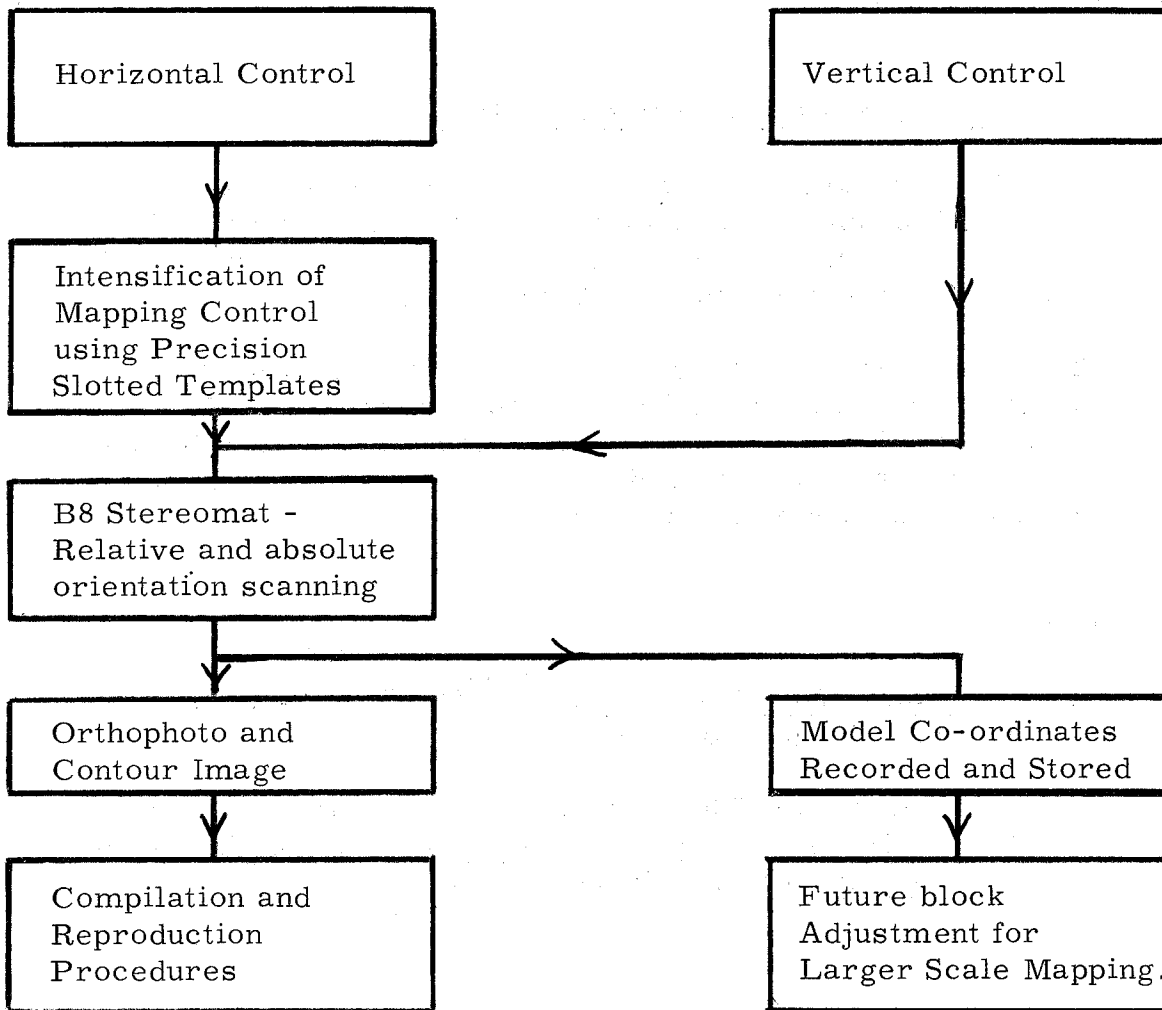



"SKINNER" SLOTTED TEMPLATE CUTTER

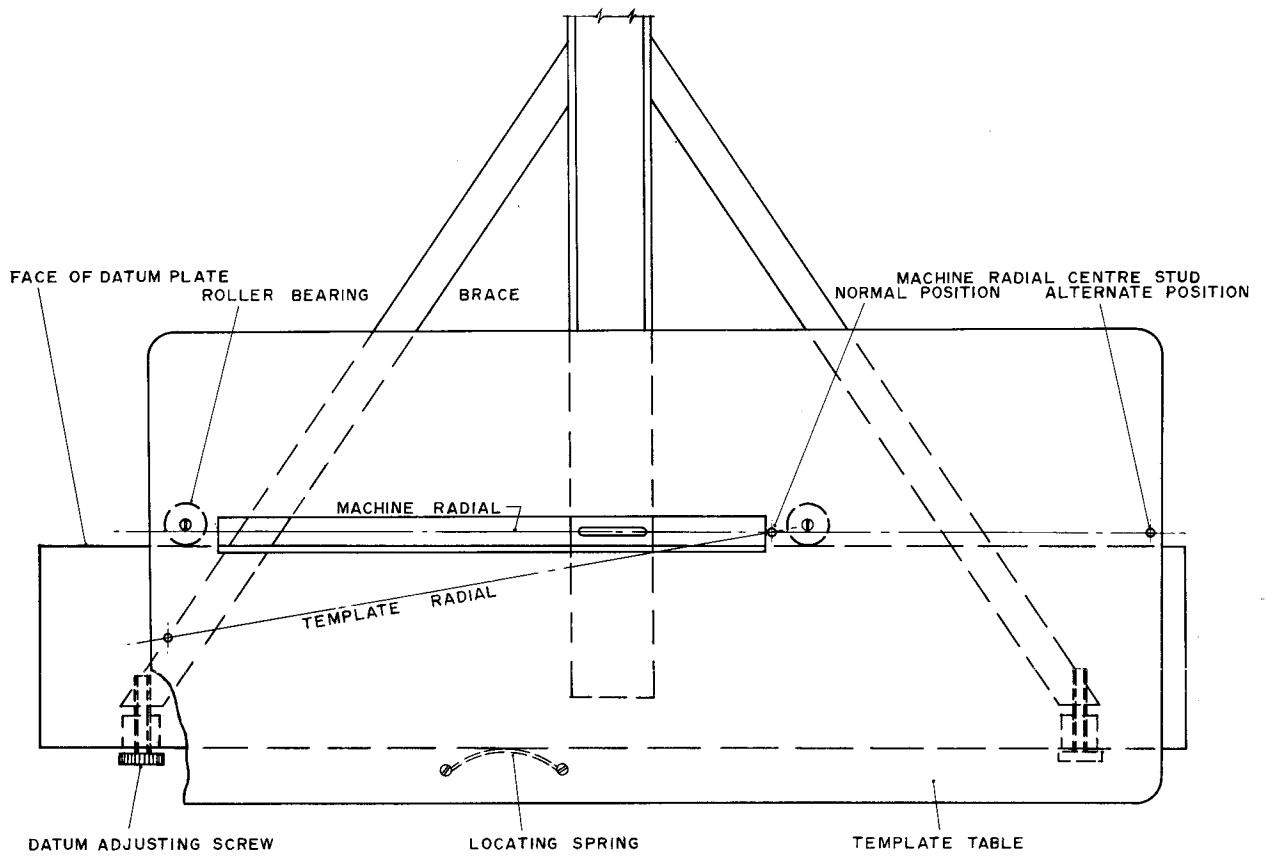

DIAGRAMMATIC SKETCH OF CUTTER

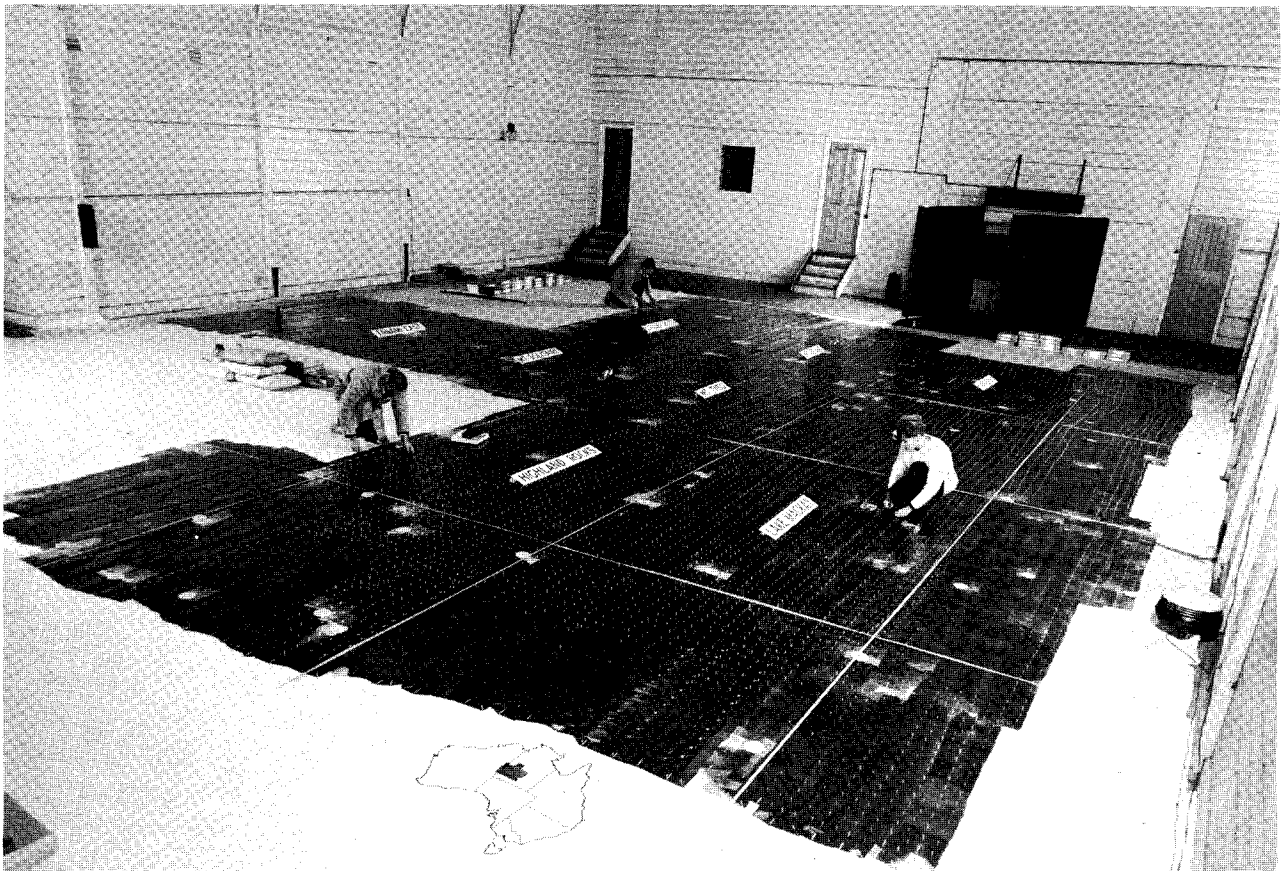

SLOTTED TEMPLATE ASSEMBLY FOR AUSTRALIA 1:250,000 R502 SERIES.

Area: 88,000 sq. miles; 1:50,000 template scale; Number of templates, 8,300; Number of studs, 17,000;
Map Control: astro and geodetic.

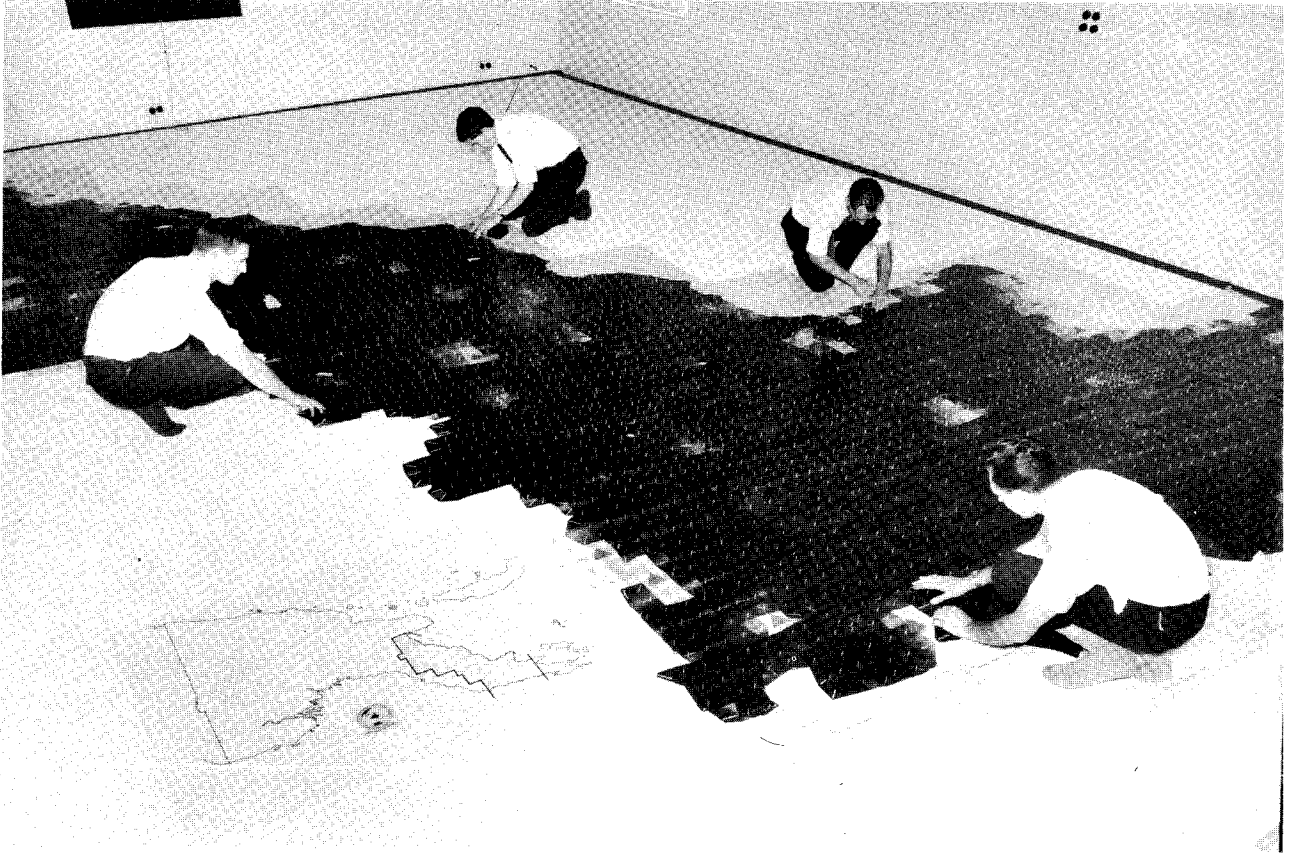

SLOTTED TEMPLATE ASSEMBLY FOR 1:50,000 BASE MAPPING FOR RESOURCES SURVEYS IN PAPUA AND NEW GUINEA.

Area: 20,000 sq. miles; 1:50,000 template scale; Template material : X ray film and 'Cobex',
Map control : geodetic.