

UNSW

Wayfinding and Signage Standards

Revision 12
14 December 2023

Chapter G.1 (Sections 01 - 08)

For sections 09 - 12, refer to chapter G.2

For sections 13 - 17, refer to chapter G.3

For sections 18 - 23, refer to chapter G.4



UNSW
SYDNEY

Contents

01: Introduction – Page 3

Legal Statement
Introduction
Maintaining the UNSW design standards
Acknowledgements
Contact List
Using This Manual
Signage Summary Guide
Definitions

02: Wayfinding Strategy – Page 12

Signage Objectives
Campus Precincts
Campus Perimeter & Entry Numbering
Rationalised Circulation
Accessibility Strategy
Placemaking Opportunities
Wayfinding Strategy Summary

03: Terminology & Addressing – Page 19

Terminology Overview
Terminology Categories
Addressing Strategy
Room Numbering Protocol
Signform Hierarchy
External Messaging Allocation

04: User Journey – Page 40

Wayfinding Aim
External User Journey
Typical Internal User Journey
Public Accessible Destinations
Public Accessible Destinations User Journey
Wayfinding Placement
Campus Entrances
Campus Circulation
Campus Building Identification
Campus Zones

05: The Process – Page 60

Wayfinding Strategy Overview
Process Overview
Step 1: Audit
Step 2: Sign locations
Step 3: Sign selection
Step 4: Sign content
Step 5: Procurement
Step 6: Site inspection
Step 7: Artwork creation
Step 8: Approval of artwork
Step 9: Creation of shop drawings
Step 10: Approval of shop drawings
Step 11: Fabrication
Step 12: Installation
Step 13: Defects inspection
Step 14: Rectification
Step 15: Final approval

06: Conceptual Overview – Page 75

2025 Masterplan Drivers
Concept Pillars
Concept – Limitless Landscape

07: Graphic Standards – Page 82

Logo Overview
Signage Colour Palette
Typography
Arrows
Pictogram Suite
Messaging Hierarchy
Messaging Layouts

08: Construction Standards – Page 96

Finishes Schedule
Signage Heights & Standards
Totem Signforms
Layered Panel Signforms
Digital Signforms
Suspended Signforms
Cantilevered Signforms
Wall Mounted Signforms
Direct Applied Graphics
Off-the-shelf

Section

1.0

Introduction

This section provides an overview of the processes and responsibilities including definitions of key terms.

Legal Statement

Introduction

Maintaining the UNSW Design Standards

Acknowledgements

Contact List

Using This Manual

Signage Summary Guide

Definitions

Legal Statement

These standards have been prepared by UNSW for information purposes only. They are provided by UNSW as a guide only. Compliance with the Standards does not in any way replace, modify or diminish any obligation to comply with the terms and conditions of any agreement, contract or any other arrangements you may have with UNSW or its related companies, all laws and any applicable industry standards or regulations, including without limitation the Building Code of Australia and Australian Standards, in relation to the provision of the services.

UNSW has the right to change the Standards at any time without notice. Neither UNSW nor any of their directors, employees and associates, gives any representation or warranty as to the reliability, completeness or accuracy of the information contained in the Standards and does not accept any liability for any loss or damage, however caused, as a result of any person relying on any information in these Standards. The disclaimer is subject to any applicable contrary provisions of the Trade Practices Act. Copyright in the information contained in these Standards is owned by UNSW (ABN 57 195 873 179). You may use this information for the purpose provided only. You may reproduce this information in hard copy solely for the purpose of providing services to UNSW. The information may not otherwise be reproduced and must not be distributed or transmitted to any other person or incorporated in any way into another document or other material.

Copyright© 2023 UNSW
(ABN 57 195 873 179)

Introduction

These standards have been created based on a sculptural yet modular sign system developed for UNSW. The signs are designed to have enduring adaptability and organic expression across key components. The sign family demonstrates a clear hierarchy and consistent set of relationships to ensure ease of use and implementation.

The purpose of these standards is to provide a set of protocols and tools to deliver consistent signage that is highly functional and operates in accordance with relevant regulations.

Once installed, the improved wayfinding will enhance the user experience by making it easier to navigate, as well as establishing a sense of place in keeping with the UNSW brand and 2025 UNSW Vision of the site.

Maintaining the UNSW Design Standards

These signage principles form part of UNSW's design standards and provides consultants, contractors and UNSW staff with tools required to plan, schedule, construct and install wayfinding signage across multiple locations. It is incumbent on all staff and on all contractors and consultants engaged by UNSW to apply these standards when installing or replacing signage as part of any new development, refurbishment or maintenance works.

The correct application of these standards will ensure consistency across all our branches and assist students, visitors and staff in navigating around our buildings and spaces. The contents of this manual and the design of all signage are based on industry best practice as well as extensive research and consultation with UNSW.

The manual is owned and managed by UNSW. They will assist all staff, consultants and contractors in clearly understanding how to procure signage solutions that meet their particular requirements.

Acknowledgements

The UNSW Signage Standards were prepared in 2018 by Urbanite.
The manual is copyright and remains the property of UNSW.

The following people were involved in the delivery of this manual.

UNSW Project Control Group

Alexander Frankl Associate Director, Development Estate Management
Geoffrey Leeson Senior Manager, Development Estate Management
Janine Deshon Design Manager, Development Estate Management
Niki Douglas Senior Manager, Development Estate Management
Amber Greenhalgh Assistant Manager, Development Estate Management
Tony Walsh Director, Property Management
Lisette Araujo Administrative Officer, Asset Management
Sancha Cromie Associate Director, Asset Management
Paul Kiefer Senior Manager, Information & Systems
Greg Kaplan Associate Director, Facilities Management
Ingrid Bascur Senior Manager, Estate Improvement

Wayfinding Strategy and Signage Design (Frost*Collective)

Carlo Giannasca Managing Director
Brenda Schofield Head of Environments
Sarah Estens Creative Director
Lalitha Balasubramanian Senior Designer
Michael Pinn Senior Designer
Tom Fowler Senior Designer

Signage Contractor Advisor (Cuneen Signs)

Stuart Dobbie Project Manager

Using This Manual

These standards have been prepared to meet the brief requirements established by UNSW. The signage design and standards have been prepared to assist in the delivery of legible wayfinding across all branches through signage principles and designs for internal signage. The Standards are further categorised into identification, directional and operational sign types that occur across the campus.

In most applications of the Signage Standards some interpretation of the standards will be needed as will consideration of issues of sign planning relative to specific circumstances of a site. The use of suitably qualified design consultants is recommended for implementation of signage within the UNSW campus.

Who will use these standards?

It is envisaged that a variety of people will utilise the Standards to deliver signage at UNSW for new signage implementations and updating existing signage, including the following;

- UNSW
- Designated staff members
- External design/building consultants including:
 - Architects
 - Interior architects
 - Project manager
 - Structural engineers
 - Signage consultants
 - Signage contractors

The Standards have 25 sections that document various aspects of the signage design and documentation process and an appendix that provides additional information to assist in the preparation of signage programs. Whilst some interpretation of the Standards in relation to sign placement may be required to ensure signage does not impede circulation and is integrated with specific site and built forms, the approach to choosing sign types, message content and overall look and feel of the sign forms should be strictly adhered to. This will ensure a consistent wayfinding approach across all areas, resulting in legible wayfinding for both familiar and first time users.

• Section 1: Introduction

Provides an overview of the processes and responsibilities including definitions of key terms.

• Section 2: Wayfinding Strategy

Provides an overview of the wayfinding strategy by defining the overall objectives of the system. It documents the campus precincts, entry and decision points, pedestrian, accessibility and vehicular circulation paths.

• Section 3: Terminology & Addressing

This section identifies the correct terminology that should be used on signage and articulates the addressing approach and hierarchy.

• Section 4: User Journey

Identifies examples of external and internal user experiences across the Kensington Campus and in a typical faculty building.

• Section 5: UNSW External Road Terminology

Documents the maintenance procedures and Maintenance Manual requirements.

• Section 6: Wayfinding Principles

Outlines the overarching wayfinding principles that underpin the system.

• Section 7: The Process

Outlines the step by step process that needs to be undertaken when implementing the wayfinding system.

• Section 8: Conceptual Overview

Outlines the conceptual pillars that underpin the creative for the wayfinding design.

• Section 9: Graphics Standards

Outlines the graphic standards that apply to the wayfinding design.

• Section 10: Construction Standard

Documents the maintenance procedures and Maintenance Manual requirements.

• Section 11: Sign Type Library

General overview of every single sign type within the wayfinding family

• Section 12: Identification

Documents all the identification signs of the system including specifications for both external and internal signs

• Section 13: Directional Series

Documents all the directional signs of the system including specifications for both external and internal signs.

• Section 14: Car Park Series

documents all the car park signs of the system including specifications for both external and internal signs

• Section 15: Operational Series

Documents all the operational signs of the system including specifications for both external and internal signs

• Section 16: Statutory Series

Documents all the statutory signs of the system including specifications for both external and internal signs

• Section 17: Temporary & Display Series

Documents all the temporary and displays signs of the system including specifications for both external and internal signs

• Section 18: Environmental Graphics

Documents all the environmental graphics of the system including specifications for both external and internal signs.

• Section 19: Specialty Series

Documents all the specialty sign types of the system

• Section 20: Map

Summary overview of the design intent and typical specifications of the map system.

• Section 21: Templates

Summary overview of the design intent and placement of printed and digital templates.

• Section 22: Shop Drawings

A collection of construction details of every sign within the system

• Section 23: Maintenance

Documents the maintenance procedures and Maintenance Manual requirements.

• Section 24: Roll Out

Identifies protocols in rolling out the signage system across the UNSW site

• Section 25: Appendix

Signage Summary Guide

The **Signage Summary Guide** will help UNSW staff and consultants find particular signage packages quickly, especially on smaller projects or minor maintenance works. Cross referencing to/from each individual sign type must be followed to ensure signage is correctly specified and content is correctly scheduled. There are five typical types of signage roll outs, from one new door sign to a whole building fit out. The guide below illustrates the five recommended steps to assist in developing cohesive wayfinding signage across the UNSW campus.

What is the task?	Example	Who is responsible?	Signs required	Sections to consult	Process
Minor sign maintenance	Replacing or creating room, office or workstation sign	Unit/Faculty Facilities, Office or Operations Manager	<ul style="list-style-type: none"> ID (Identification) Series 	Section 7: Process Sections 12 – 19: Sign types	Identify requirement and contact Facilities Information Manager, FMO to assist with procurement
Small fitout or minor upgrade to existing space	Fit out of a back-of-house office area	UNSW Project Manager and relevant consultants/contractors	<ul style="list-style-type: none"> ID (Identification) Series OP (Operational) Series ST (Statutory) Series 	Section 7: Process Section 9: Graphic Standards Section 10: Construction Sections 12 – 21: Sign types Section 21: Templates	Specify signage in consultation with end-user/stakeholders and procure signage with assistance of Facilities Information Manager, FMO
Installing statutory signage only	Building contractor only has responsibility for statutory signage provision	UNSW Project Manager and relevant consultants/contractors	<ul style="list-style-type: none"> ST (Statutory) Series 	Section 7: Process Section 9: Graphic Standards Section 10: Construction Sections 12 – 21: Sign types	Specify signage in consultation with end-user/stakeholders and procure signage with assistance of Facilities Information Manager, FMO
Major fitout	Fit out of major public space, such as student informal learning area	UNSW Project Manager and relevant consultants/contractors]	<ul style="list-style-type: none"> ID (Identification) Series DR (Directional) Series OP (Operational)Series) ST (Statutory) Series 	Entirety of Standards: projects of this complexity require a complete understanding of UNSW's signage standards	Specify signage in consultation with end-user/stakeholders and procure signage with assistance of Facilities Information Manager, FMO
Major project	New building or major extension	UNSW Project Manager and relevant consultants/contractors	<ul style="list-style-type: none"> Full signage family, internal and external. 	Entirety of Standards: projects of this complexity require a complete understanding of UNSW's signage standards	Specify signage in consultation with end-user/stakeholders and procure signage with assistance of Facilities Information Manager, FMO

Definitions

Accessible

Having features to permit use by people with disabilities. (BCA)

Arrow Zone

Area at left or right end of signs reserved for arrow

Artwork

High quality, final electronically drafted design suitable for production format

AS

Australian Standard

Ascender

Portion of lower case letter above x-height

BCA

Building Code of Australia – current edition

BOH

Back-of-House destinations are primarily not student facing destinations

Braille

A system of touch reading for the blind, which employs raised dots, evenly arranged in quadrangular letter spaces or cells

Descender

Portion of the lower case letter below x-height

Directional Signs

Includes directories and directional signs. Directory signs list destinations, Directional signs direct to places and destinations

FCL

Finished ceiling level

FFL

Finished floor level

Fixtures

Fixed items that require service connection (e.g. electrical, hydraulic, mechanical)

FOH

Front-of-House destinations are primarily student facing destinations

Fonts

A set of type of one particular face and size

FMO

Facility Management Operations, responsible for ensuring that the signage standards are maintained in the development and implementation of all signage across the University

Hearing loop

Assistive listening system, used with International symbol for deafness

Identification signs

Signage identifying places and destinations

Justified

To adjust the spaces between words in (a line of type) so that it is of the required length or (of a line of type) to fit exactly

Layout

A drawing or sketch of a proposed sign-face

Letterform

Space between adjacent letters

Logo

Name of an organisation or product in a special design used as an identifying mark

Lowercase

Type without capitals

Luminance contrast

The amount of light reflected from one surface or component, compared to the amount of light reflected from the background or surrounding surfaces

Masterplan

A drawing, typically utilising a building plan or landscape plan indicating sign locations and messaging utilising the sign code

Message Zone

Area between arrow zones reserved for message wording

OHS

Occupational Health and Safety Act

Operational Signs

Signage identifying staff and BOH destinations and illustrating statutory messages

Pictogram

A picture representing a word or idea

Sign

A combination of graphic elements on a background to convey a message - includes visual, auditory or tactile devices

Sign Code

A system that allocates signs into categories (ID, DR, OP) and includes the allocation of level and an individual number to allow identification of each sign item

Signage

Collection of signs

Signage Schedule

A document illustrating sign types (via a sign code) the message to be illustrated on the sign (including arrows, written text, pictograms) to be read in conjunction with the Masterplan

Symbol

A graphic or pictorial device used to represent objects or concepts

Tactile Signage

Signage incorporating raised text/or symbols to enable touch reading by the blind and touch enhancement for visual perception for visually impaired readers

Template

Master device with which many reproductions of the same element can be made

Typeface

The styling of lettering or alphabet

Typography

The use of lettering or alphabet

Wayfinding

Strategy to assist people in finding their way, includes signage

Word Space

Space between adjacent words

X-Height

Height of the lower case letter 'x'

Section

2.0

Wayfinding Strategy

This section outlines key strategy recommendations that inform the design and placement of signage.

Signage Objectives

Campus Precincts

Campus Perimeter & Entry Numbering

Rationalised Circulation

Accessibility Strategy

Placemaking Opportunities

Wayfinding Strategy Summary

Signage Objectives

Urbanite have developed a strategic signage approach for UNSW:

A community that strives for communication, collaboration and celebration of its achievements while enabling physical connection to achieve academic excellence.

The UNSW sign family has been developed to respond to typical wayfinding journeys for both pedestrian and vehicular users approaching the site via public transport, private vehicle, bicycle or on foot.

While the sign content has been designed to prioritise student wayfinding, other users including staff, external consultants and visitors are catered for in the permanent signage for campus destinations. It is envisaged that digital content to be deployed across the site will assist in highlighting further event-sensitive locations and will significantly reduce the requirement for temporary signage.

The signage approach drew upon a number of key objectives:

1. Clarity

Consistent and legible identification and nomenclature of the perimeter and entry points, with a legible addressing solution that creates a relationship between a location in a precinct, position on a street, walk or way and its alphanumeric building code.

2. Flexible

To deliver a signage system which addresses changeability of tenant identification and messaging, along with adaptability to differing environments.

3. Integrated

Adoption and identification of key integrated destinations in addressing, mapping and signage, with a rationalised network of named streets, walks and ways critical for understanding and navigating the campus and ensuring the system is integrated into the fabric of UNSW.

4. Interactive

To assist the growth of the UNSW community through a dialogue with the campus and between its residents, in consideration of non-English speakers, disabled and new time visitors, using digital or placemaking solutions.

5. Innovative

To create an interpretive overlay that deepens the understanding of place that is unique to the UNSW campus. This overlay will provide an engaging expression of landscape, history and technological achievement.

6. Iconic

A distinct brand transition across a user journey to ensure the understanding of the overarching UNSW identity while allowing individual university functions to identify themselves under the umbrella brand.

7. Declutter the Campus

A wholistic signage system that promotes clarity and simplicity, removing redundant/old signs and consolidating information as much as possible.

Key environmental factors that have been considered in the development of the wayfinding standards are:

- Campus planning
- Built form
- Colour
- Materiality
- Static information
- Dynamic information
- Digital integration

Key operational factors that have been considered in the development of the wayfinding standards are:

- Addressing
- Terminology
- Staff, student and visitor communication
- Multilingual users
- Initial roll out

Campus Perimeter & Entry Numbering

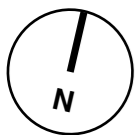
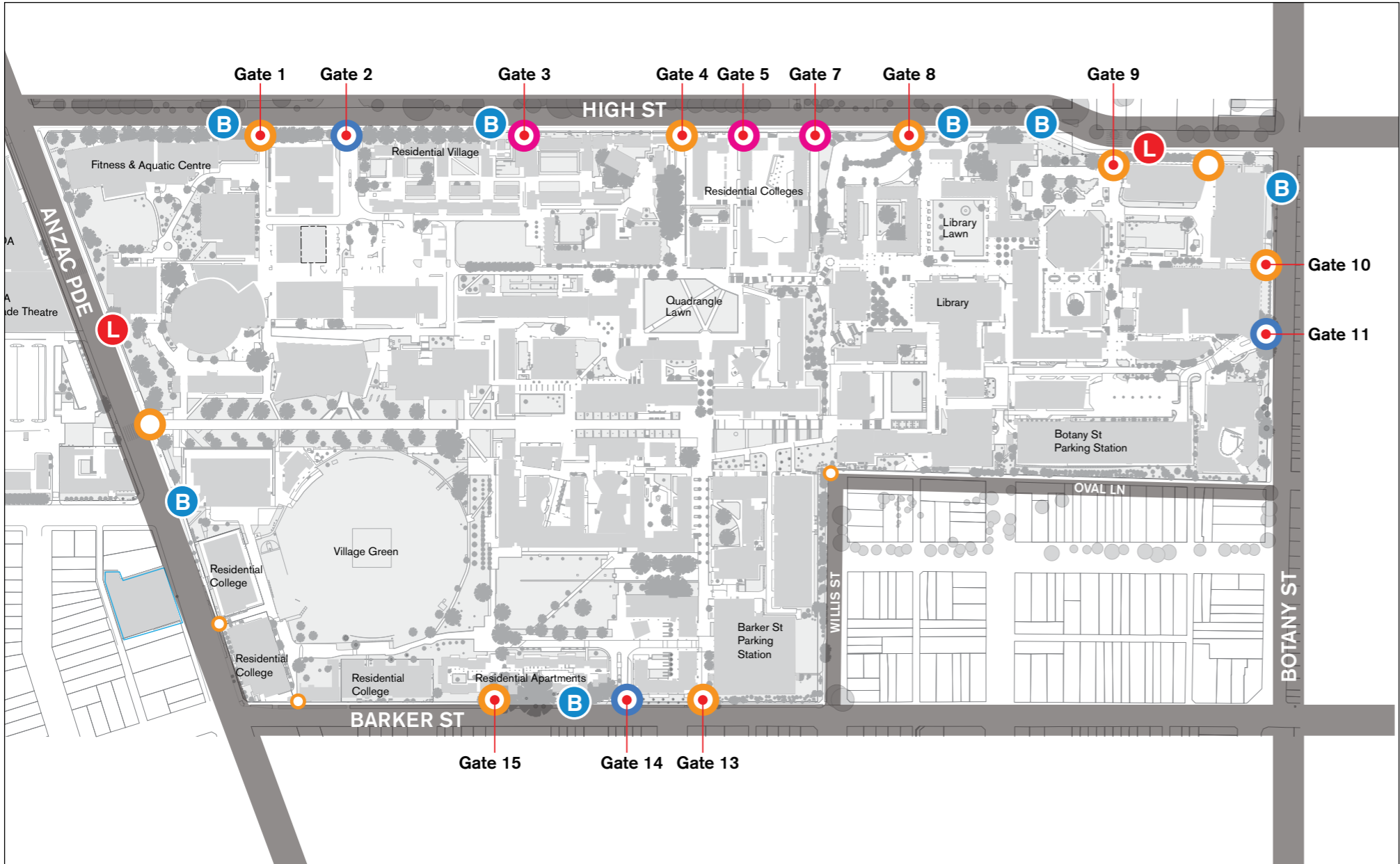

The UNSW Kensington Campus has vehicle access from the North, East and Southern perimeters. Vehicle access points provide footpaths for pedestrian access.

Pedestrian access can be divided into major and minor access points.

Public transport can be accessed by all four main roads surrounding the site currently through buses.

The site's Northern perimeter has the most concentrated pedestrian flow with seven major entry points located along High Street. High Street is currently serviced by four bus stops and a future Light Rail stop. High Street is the ceremonial entrance to the site.

ANZAC Parade, although considered the major visual access to the site, provides only pedestrian access to the university.

Barker and Botany Street provide both major pedestrian access and vehicular access to the university's public car parking facilities.

As identified, the university has three minor pedestrian entry points opened during the university's contact hours.

The university uses a consecutive numeric coding system to identify both vehicular and pedestrian entry points.

KEY

- B TfNSW Bus Stop
- L TfNSW Light Rail Stop
- Public Vehicular & Pedestrian Entrance
- Major Pedestrian Entrance
- Minor Pedestrian Entrance
- Authorised Vehicular Entrance

Rationalised Circulation – Vehicle

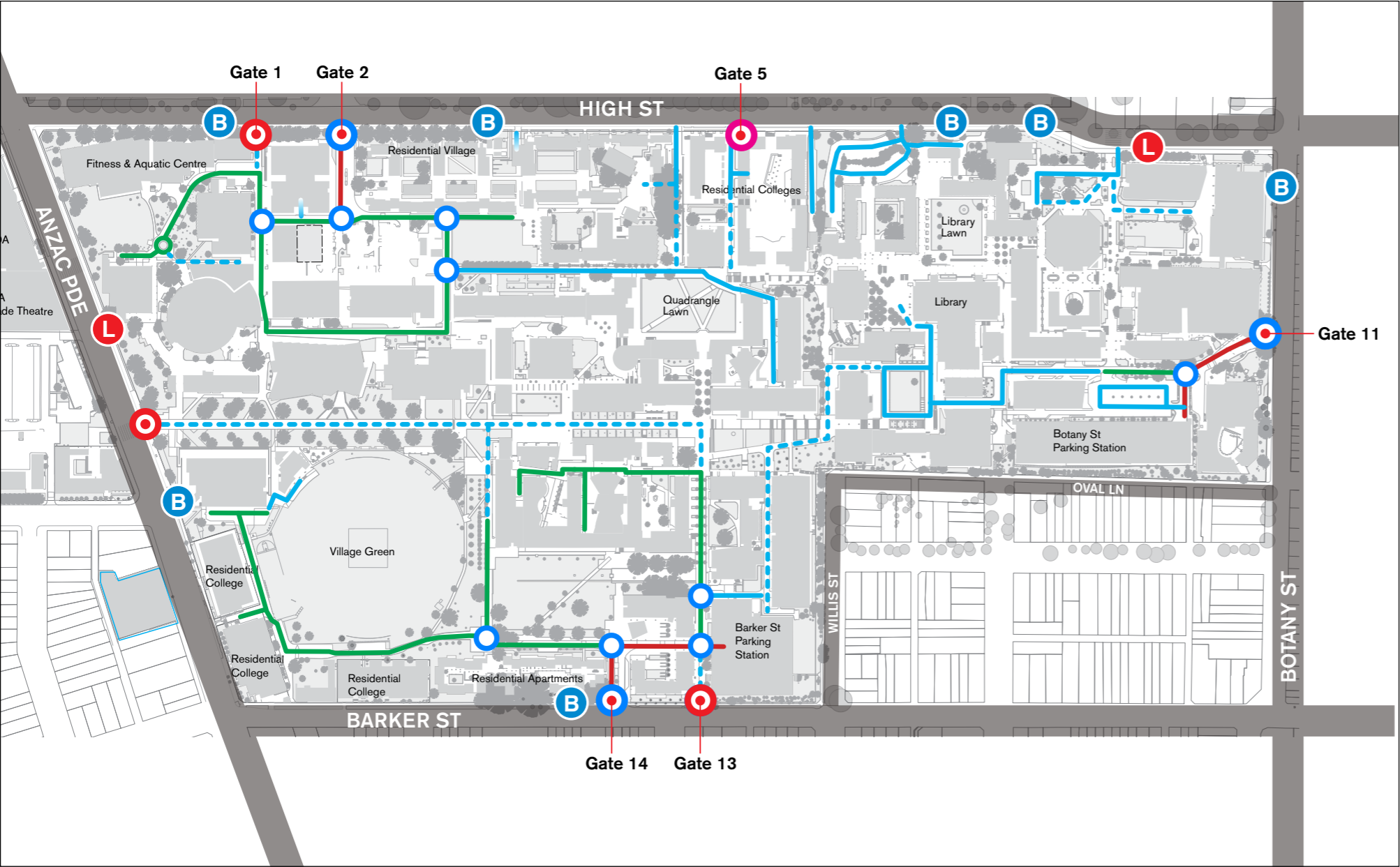

The university's vehicle access sites can be divided into three categories:

- 1. Primary entry**, providing access within the university's campus
- 2. Secondary entry**, providing access to vehicles with authorised permits
- 3. Emergency vehicular access only**, obtained through the removal of bollards.

Vehicle circulation within the site is primarily university building services and other authorised vehicles.

Primarily public vehicle circulation is limited to drop off, within the Northern Vehicle entry, and access to the multi-level parking stations from both Barker and Botany Street entrances. Barker Street's secondary public vehicle circulation provides access to the resident and well-being precincts and accessible parking within the 'Old Main Building'. High Street's secondary public vehicle circulation provides access to buildings and facilities within the North Western Quarter of the campus. Additional Emergency Vehicle access is provided through bollard removal along ANZAC Parade, Barker and High Streets.

KEY

- B TfNSW Bus Stop
- L TfNSW Light Rail Stop
- B Public Vehicular & Pedestrian Entrance
- O Authorised Vehicular Entrance
- O Emergency Vehicular Access Only
- Primary Vehicular Route
- Secondary Vehicular Route
- Authorised Vehicular Route
- Emergency Vehicular Route

Rationalised Circulation – Pedestrian

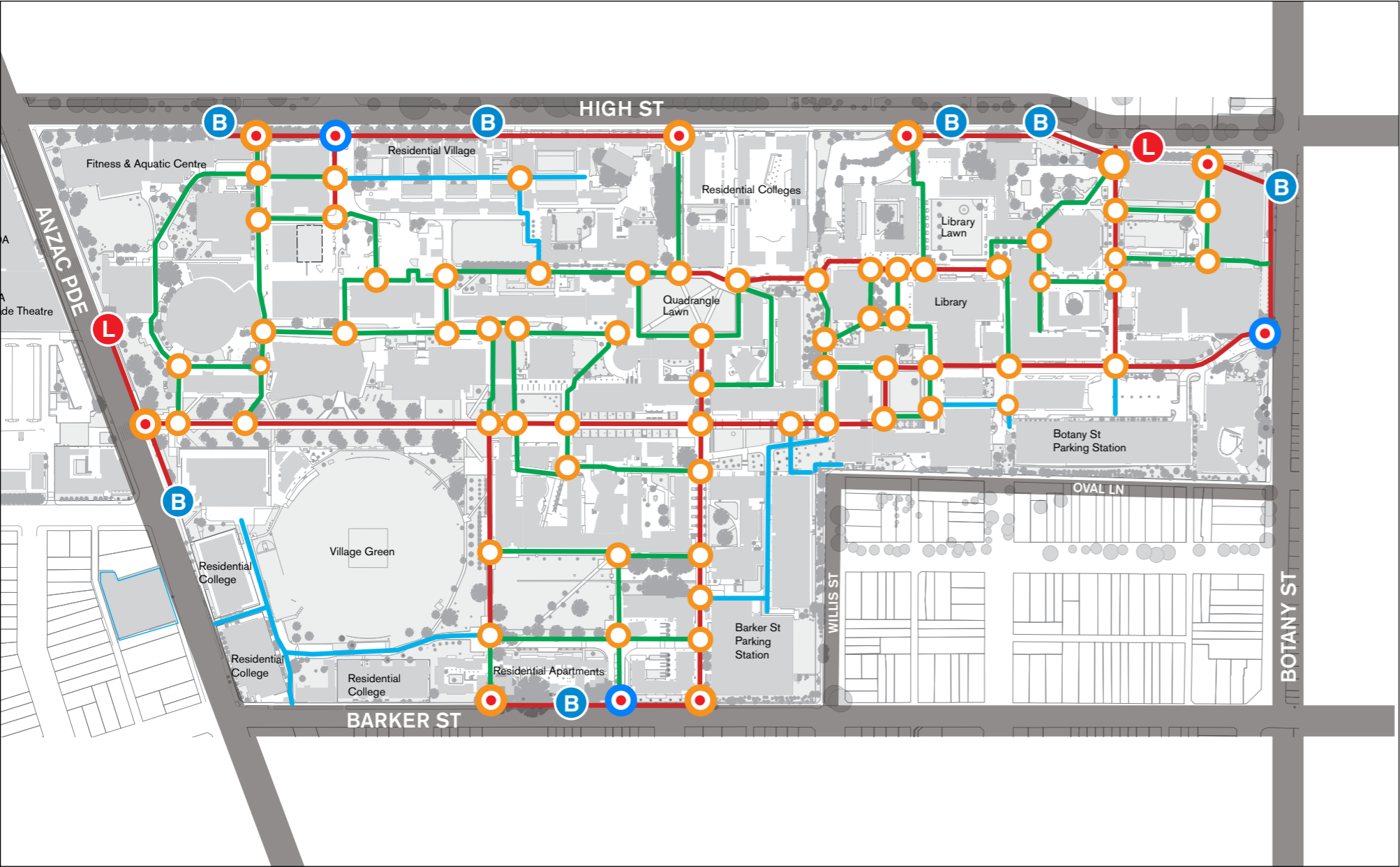

The university's pedestrian circulation can be divided into seven categories:

- 1. Primary circulation** starts at along the campus' perimeter from public transport drop off points, leading to the major circulation arteries within the campus:
- 2. University Mall** running west-east through the campus' centre from ANZAC Parade to the Upper Campus connecting with Library Road to finish at Botany Street;
- 3. Science Road** off Barker Street, running south-north to University Mall;
- 4. Engineering Road** off Barker Street, to the Quadrangle Lawn;
- 5. College Road** from the Quadrangle Lawn running East to the Library Lawn;
- 6. Chancellery Walk** off High Street, running south connecting with Library Rd; and
- 7. Gate 2 Avenue** off High Street, intersecting with Third Avenue.

Secondary and residential / car park circulation paths extend from the above major circulation paths.

KEY

- B TfNSW Bus Stop
- L TfNSW Light Rail Stop
- Public Vehicular & Pedestrian Entrance
- Pedestrian Entrance
- Decision Point
- Primary Pedestrian Route
- Secondary Pedestrian Route
- Residential & Car Park Pedestrian Routes



Accessibility Strategy









There is both an ethical and regulatory responsibility to provide wayfinding elements for the wider campus community.

Currently the only accessible paths identified are subtle signage at or to lifts. Accessible path wayfinding is presented within a micro environment not suitable for wheelchair users to plan their campus journey.

The significance of the diagram is the identification of wheelchair negotiation at nine different levels within the campus. The wheelchair paths were identified through extensive on site observations and campus wayfinding should assist wheelchair users in locating adequate accessible paths for aiding navigation.

KEY

-  TfNSW Bus Stop
-  TfNSW Light Rail Stop
-  Accessible Path
-  Public Accessible Parking
-  Lift Access to next level
-  Ramp Access to Next level
-  Accessible Pedestrian Campus Entrance

Wayfinding Strategy Summary

Through the thorough analysis of campus conditions and also the future 2025 UNSW Strategic Plan, Urbanite has formulated a number of strategic wayfinding principles to assist positioning the signage system throughout UNSW.

These strategic wayfinding principles assist in ensuring that all design responses and locations of signage work to ensure an overarching, world-leading wayfinding system is implemented across all aspects of UNSW .

These strategic wayfinding principles consist of:

1. UNSW Experience

It is imperative for the signage system to enhance the UNSW experience for all users. Special consideration has been given to campus and building entry points and also users circulating around the campus and the relevant sign forms they encounter. The signage design is a celebration of the UNSW brand and the unique location of the campus and subsequently wayfinding positioning strategies should position signage in visible and prominent locations. High quality contractors should be engaged to ensure the finish signage product reflects the high quality UNSW brand. A number of campus areas have been identified on the previous analysis pages for special consideration where signage can be utilised to greatly enhance the UNSW user experience.

2. Clear & Concise

A critical component of a successful wayfinding system is clear and concise messaging and signage positioning. When positioning signage, a "less is more" approach should be taken and choosing messaging that will allow extremely clear and concise directional and identification purposes. Particular messaging should be selected for signs with a special focus on avoiding over-messaging or over-signing particular areas. Large amounts of messaging confuse and detract from the user experience and this should always be considered when positioning signage.

3. Consistency

A number of positioning guides have been outlined for each of the sign forms described in this document, including comprehensive naming and messaging hierarchy listings. It is critically important that consistency across all forms, messaging and positioning is maintained across the campus. The signs have been designed to fulfil certain roles and ensuring consistency in signage for areas such as building and precinct entries aid in the wayfinding strategy to ensure users know what type of signage to look for when looking for particular facilities and conditions.

4. Inclusive

Through the analysis of accessible pathways throughout the university, it is imperative that accessible paths and facilities are indicated and directed to on relevant wayfinding signage. This also includes features such as accessible amenities and car park areas. Affecting elements such as signage text heights, for users with reduced eye sight, needs to be considered across all wayfinding touch-points to ensure that positioning and selected messaging assist in creating an inclusive campus that all users can successfully navigate.

5. Integrated & Embedded

The positioning of wayfinding signs need to ensure that all insertions feel that they are integrated and embedded within the urban fabric of the UNSW campus. This includes positioning freestanding signs within garden beds and landscaping, where possible, and ensure major circulation routes are not obstructed by signage positioning. Wall mounted signs typically take priority over freestanding and special consideration is required when mounting to or within buildings. Architects and landscape architects should be consulted when applying the signage system to their buildings and landscaping to ensure that the signage system does not feel like it has been positioned as an after-thought but rather supports the architectural or landscape design intent.

6. Sustainability

Both using sustainable materials in the signage construction, such as LED illumination, and sourcing power for signage illumination sustainably work in conjunction with sustainability considerations in the position and changeability of the wayfinding system. To ensure minimal material use, the signage system consolidates a number of functional requirements into single sign forms, ensuring that fewer signs need to be produced. Special consideration is also given to changeability through strategic panelling, ensuring that as sign messaging is required to change, minimal energy and material is required. Consideration of the positioning of the wayfinding should always consider this sustainability principle and look at ways the amounts of signs can be reduced.

Section

3.0

Terminology & Addressing

This section identifies the correct terminology that should be used on signage and articulates the addressing approach and hierarchy.

Terminology Overview

Terminology Categories

Addressing Strategy

Signform Hierarchy

External Messaging Allocation

Terminology Overview

0

Primary Campus Identification

(Main campus identity)

Primary campus identification through UNSW logo branding:

- UNSW Logo

1

Secondary Campus Identification

(Optional)

Optional secondary campus identification as unique campus name in addition to logo:

- AFDA
- Arts, Design & Architecture
- CBD Campus (O'Connell Street)
- CBD Campus (Pitt Street)
- Cliffbrook Campus
- Kensington Campus
- Manly Vale Campus
- Randwick Campus

2

Primary Gate Identification

(Entry Points)

Major and minor campus entry points:

- Gate 1
- Gate 2
- Gate 3
- Gate 4
- Gate 5
- Gate 6
- Gate 7
- Gate 8
- Gate 9

3

Streets & Walkways

Major walk ways and streets at the perimeter and within the campus (Kensington campus specific):

- ANZAC Parade
- Avenue West
- Barker Street
- Basser Steps
- Botany Street
- Chancellery Lane
- Chancellery Walk
- College Walk
- Engineering Road
- Fig Tree Lane
- International Road
- Library Road
- Library Walk
- Southern Drive
- University Mall
- Union Road
- Willis Lane
- Willis Street

The terminology list has been created to ensure consistent naming and addressing hierarchy of locations and areas across UNSW. When developing information for wayfinding signage it is important to use only approved naming and messaging, by referring to the terminology list.

This list can be added to and changed with the appropriate internal UNSW approvals and should be reviewed on a regular basis to check for current and future campus alignment.

The following pages outline the exact terminology that is approved for use across the Kensington campus only. The same terminology structure should be implemented main destinations for campuses outside of the Kensington campus.

Note:

For further detail on category definitions and destination categorisation protocol, refer to 'Section 5, The Process, Sign Content'.

Terminology Overview

4

Level & Vertical Circulation

Internal identification system for multi level and subterranean buildings with multiple destinations:

- Level 2 (Continuous)
- Level 1M
- Level 1 Upper
- Level 1
- Ground
- Basement 1
- Basement 2 (Continuous)

5

Primary Campus Destinations

(Main educational & cultural buildings)

Major buildings used by external and internal audiences, limited to (Kensington campus specific):

- AGSM (G27)
- Ainsworth Building (J17)
- Arc UNSW (D17)
- Ian Jacobs Building (D26)
- Biological Sciences South (E26)
- Blockhouse (G6)
- Building L5 (L5)
- Chancellery (C22)
- Civil Engineering (H20)
- Colombo House (B16)
- Computer Science Building (K17)
- Dalton Building (F12)
- June Griffith Building (F10)
- Old Main Building (K15)

List continues on following pages

6

Secondary Campus Destinations

(Residential, non-educational facilities & grounds)

Major shared spaces used by external and internal audiences, (Kensington campus specific):

- Alumni Park
- Barker Apartments (N13)
- Basser College (D17)
- Colombo House (B16)
- Creston College (A25)
- Fig Tree Hall (B18)
- Goldstein College (B17)
- House at Pooh Corner (N8)
- International House (C6)
- Kanga's House (O14)
- Library Lawn
- Michael Birt Lawn
- New College (L6)
- New College Postgraduate Village (H3)

List continues on following pages

7

FOH Staff Destinations

(Faculty Offices)

Secondary internal destinations, used primarily by staff, limited to (Kensington campus specific):

- Art & Social Sciences Faculty Office (C20)
- Art, Design & Architecture Faculty Office (H13)
- Engineering Faculty Office (K17)
- Law & Justice Faculty Office (F8)
- Medicine & Health Faculty Office (C27)
- Science Faculty Office (F12)
- Business School Faculty Office (E12)
- Estate Management (F23)

8

Student Services Destinations

Tertiary internal destinations, used primarily by students, limited to (Kensington campus specific):

- Accommodation Services (C18)
- Alumni Association (C22)
- Careers and Employment Office (E15)
- Chaplains (E4)
- Co-op Program & Scholarship (F21)
- Counselling Service (E15)
- Educational Support Service (F20)
- Equity and Disability Unit (F20)
- Foundation Studies (L5)
- Freehills Law Library (F8)
- Future Students Office (H13)
- Graduate Research School (M15)
- FM Assist (F21)

List continues on following pages

9

Retail & Hospitality Destinations

Commerce-use, non-educational related facilities (Kensington campus specific):

- Arc Graduation & Gift Shop
- Australia Post
- Boost Juice
- Bar Navitas
- Commonwealth Bank
- Café
- Dentist
- Douglas Hanly Moir Pathology
- IGA
- Medibank Private
- Unisuper
- Optometry Clinic (M15)
- Pharmacy
- Physiotherapy Clinic (B8)

List continues on following pages

Terminology Overview

10

Student Facing Destinations

General-use, education related facilities, e.g.:

- CATS Room
- Laboratory
- Dark Room
- Printing Room
- Workshop
- Fabrication Lab
- Room Number (Adopting existing UNSW numbering protocol)

11

Public Services & Amenity Destinations

Minor shared spaces used by external and internal audiences: (Kensington campus specific):

- Car Park, Barker Street
- Car Park, Botany Street
- Car Park, High Street
- Car Park, Western Campus
- Toilet, Male
- Toilet, Female
- Toilet, All Genders
- Ambulant Toilet, Male
- Ambulant Toilet, Female
- Parents Room

12

BOH Staff Destinations

Staff offices/BOH destinations to be identified by name and number, e.g.:

- Staff offices
- Meeting Rooms
- Specific functions rooms e.g. IT Purchasing
- Air Conditioning & Refrigeration
- Authorised Personnel Only
- Building Services
- Cleaners Room
- Communications Room
- Dangerous Goods Store (F17A)
- Danger Switch
- Electrical Cupboard
- Fire Control Room
- Hydraulic Riser
- Lift Control Room

13

BOH Building Functions

Statutory identification and operational facilities to be identified by name/instruction, e.g.:

- FIRE HOSE REEL, FIRE HYDRANT, FIRE EXTINGUISHER
- FIRE HOSE REEL, FIRE HYDRANT
- FIRE HOSE REEL
- FIRE EXTINGUISHER
- FIRE SAFETY DOOR, DO NOT OBSTRUCT, DO NOT KEEP OPEN
- FIRE HYDRANT AND SPRINKLER BOOSTER
- COMBINED FIRE HYDRANT AND SPRINKLER BOOSTER
- FIRE SAFETY DOOR DO NOT OBSTRUCT
- WARNING SLIDING FIRE DOOR
- PORTABLE FIRE EXTINGUISHER

List continues on following pages

Terminology Categories

- UNSW Logo



Category 0:
Primary Campus Identification

(Main campus identity)

Purpose

Identify the campus precinct and major entries to the campus designed for vehicular and pedestrian viewing. To be legible for both day and night viewing.

Note

This category indicates the campus logo as the primary sign content message and does not indicate the use of the 'University of New South Wales' text on the UNSW sign family.

Terminology Categories

- AFDA
- Arts, Design & Architecture
- CBD Campus (O'Connell Street)
- CBD Campus (Pitt Street)
- Cliffbrook Campus
- Kensington Campus
- Manly Vale Campus
- Randwick Campus



Category 1:
Secondary Campus Identification

(Joining campuses)

Purpose

Where additional clarification is required regarding campus name (typically not required as campus locations are typically not located adjacent to one another) the name of the campus can be added in addition to the primary logo (Category 0).

Terminology Categories

- Gate 1
- Gate 2
- Gate 3
- Gate 4
- Gate 5
- Gate 6
- Gate 7
- Gate 8
- Gate 9
- Gate 10
- Gate 11
- Gate 12
- Gate 13
- Gate 14
- Gate 15



**Category 2:
Gate Identification**

(Primary and secondary entry points)

Purpose

Identify major and minor site entries utilised by external and internal audiences designed for vehicular and pedestrian viewing. General building lighting to assist in legibility during night viewing but typically internally illuminated.

Note

This listing is not exhaustive of all anticipated gate numbers and is a guide only.

Terminology Categories

- ANZAC Parade
- Avenue West
- Barker Street
- Basser Steps
- Botany Street
- Chancellery Lane
- Chancellery Walk
- College Walk
- Engineering Road
- International Road
- Fig Tree Lane
- Library Road
- Library Walk
- Physics Road
- Southern Drive
- University Mall
- Union Road
- Willis Lane
- Willis Street



**Category 3:
Streets & Walk Ways**

(Major perimeter and on-site walkways and streets)

Purpose

Identify the major perimeter and on-site walkways and streets within UNSW for vehicular and pedestrian viewing.

Terminology Categories

- Level 6 (Continuing)
- Level 5
- Level 4
- Level 3
- Level 2
- Level 1
- Ground
- Basement 1
- Basement 3
- Basement 2 (Continuing)



Category 4:
Level & Vertical Circulation

(Multi-level and subterranean building destinations)

Purpose

Identify the internal identification system for multi-level and subterranean buildings with multiple destinations.

Terminology Categories

- AGSM (G27)
- AGSM Theatres
- Ainsworth Building (J17)
- The Allens Hub
- Anita B. Lawrence Centre (H13)
- ARC @ UNSW
- Bank Building (F22)
- Biological Sciences South (E26)
- Blockhouse (G6)
- Building L5 (L5)
- UNSW Business School (E12)
- Patricia O'Shane Building (E19)
- Chancellery (C22)
- Chemical Sciences Theatres
- June Griffith Building (F10)
- Civil Engineering (H20)
- Civil Engineering Theatre
- Clancy Auditorium (C24)
- Colombo House (B16)
- Colombo House Theatres
- Computer Science Engineering (K17)
- Dalton Building (F12)
- Electrical Engineering (G17)
- Esme Timbery Creative Practice Lab (D8)
- Fig Tree Hall (B18)
- Fig Tree Theatre (B14D)
- Gonski Levy Theatre
- Hilmer Building (E10)
- Ian Jacobs Building (D26)
- IO Myers Studio (D9)
- John Goodsell (F20)
- Keith Burrows Theatre (J14)
- Law & Justice (F8)
- Law Library
- Law Theatres
- Library (F21)
- Lowy Cancer Research Centre (C25)
- Macauley Theatre (E15)
- Mathews Building (F23)
- Mathews Arcade (E24a)
- Mathews Theatres (D23)
- Mathews Pavilions (E24)
- Morven Brown Building (C20)
- Myers Theatre (M15A)
- New South Global Theatre
- Newton Building (J12)
- NIDA (D2)
- NIDA Parade Theatre (E2)
- Old Main Building (K15)
- Old Main Theatre
- Old Tote (B15)
- Parade Theatres
- Physics Theatre (K14)
- Quadrangle (E15)
- Red Centre Theatre
- Respository (B21)
- Rex Vowels Theatre (F17)
- Ritchie Theatre (G19)
- Robert Webster Building (G14)
- Robert Webster Theatres (G15)
- Roundhouse (E6)
- Roundhouse Unibar
- Rupert Myers Building (M15)
- Sam Cracknell Pavilion (H8)
- Gordon and Jacqueline Samuels Building (F25)
- Science and Engineering (F8)
- Science Theatre (F13)
- Scientia Building (G19)
- Solar Industrial Research Facility (G23)
- Squarehouse (E4)
- Studio One
- Tyree Energy Technologies Building (TETB) (H6)
- University Regiment (H1)
- University Regiment 2 (J2)
- Vallentine Annexe (H22)
- Wallace Wurth Building (C27)
- Willis Annexe (J18)



Category 5: Primary Campus Destinations

(Main educational & cultural buildings)

Purpose

Identify major educational and cultural buildings utilised by external and internal audiences designed for pedestrian viewing. General building lighting to assist in legibility during night viewing.

Note

The corresponding map code in brackets is to be paired with all campus destinations on both identification and directional sign types.

Terminology Categories

- Alumni Park
- Barker Apartments (N13)
- Basser College (D17)
- Colombo House (B16)
- Creston College (A25)
- Eleonora Kopalinsky Lawn
- Fig Tree Hall (B18)
- Goldstein College (B17)
- House At Pooh Corner (N8)
- International House (C6)
- Library Lawn
- Michael Birt Lawn
- Marilyn Sleigh Lawn
- New College (L6)
- New College Postgraduate Village (H3)
- Owl's House (KS9)
- Phillip Baxter College (D18)
- Physics Lawn
- Pool Lawn
- Helen Maguire Lawn
- Scientia Lawn
- Shalom College (N9)
- Tigger's Honey pot (BS22)
- University Terraces (B8)
- UNSW David Phillips Sport Field
- UNSW Residential Communities (B17)
- UNSW Village (B10)
- Village Green
- Warrane College (M7)



Category 6:
Secondary Campus Destinations
(Residential, non-educational facilities & grounds)

Purpose

Identify secondary buildings and destinations utilised by external and internal audiences designed for pedestrian viewing. General building lighting to assist in legibility during night viewing.

Note

The corresponding map code in brackets is to be paired with all campus destinations on both identification and directional sign types.

Terminology Categories

- Art & Social Sciences Faculty Office (C20)
- Art, Design & Architecture Faculty Office (H13)
- Engineering Faculty Office (K17)
- Law & Justice Faculty Office (F8)
- Medicine & Health Faculty Office (C27)
- Science Faculty Office (F12)
- Business School Faculty Office (E12)
- Estate Management (F23)



Category 7:
FOH Staff Destinations

(Faculty Offices)

Purpose

Identify major staff offices within primary educational buildings for internal pedestrian viewing.

Note

The corresponding map code in brackets is to be paired with all campus destinations on both identification and directional sign types.

Terminology Categories

- Accommodation Services (C18)
- Alumni Association (C22)
- Careers and Employment Office (E15)
- Chaplains (E4)
- Co-op Program & Scholarship (F21)
- Counselling Service (E15)
- Educational Support Service (F20)
- Equity and Disability Unit (F20)
- Fitness and Aquatic Centre (B5)
- Foundation Studies (L5)
- Freehills Law Library (F8)
- Future Students Office (H13)
- Graduate Research School (M15)
- FM Assist (F21)
- Human Resources (C22)
- Institute of Languages (L5)
- IT Service Desk (F21)
- Kingsford Legal Centre (F8)
- Learning and Teaching Unit (F21)
- Lifestyle Clinic (A27)
- Mail Centre (F23)
- Marketing Development (C22)
- New South Innovations (M15)
- Nura Gili – Balnaves Place (J17)
- Print Centre (F23)
- Religious Centre (E4)
- Research Services (M15)
- Security (B10)
- Sports Association (H8)
- Study Abroad & Exchange (F20)
- Squash Courts (B7)
- Swimming Pool (B4)
- Learning Centre (C22)
- Unisuper (B8)
- University Health Services (E15)
- UNSW Admissions (F21)
- UNSW Bookstore (E15)
- UNSW International Student Centre (H13)
- UNSW Residential Communities (B17)
- UNSW Scholarships (F21)
- UNSW Student Central (C22)
- Venues and Events (F23)



Category 8: Student Services Destinations

Purpose

Identify destinations utilised primarily by internal audiences, particularly students.

Note

The corresponding map code in brackets is to be paired with all campus destinations on both identification and directional sign types.

Terminology Categories

- Arc Graduation & Gift Shop
- Australia Post
- Boost Juice
- Bar Navitas
- Commonwealth Bank
- Café
- Dentist
- Douglas Hanly Moir Pathology
- IGA
- Medibank Private
- Unisuper
- Optometry Clinic (M15)
- Pharmacy
- Physiotherapy Clinic (B8)
- Post Office (F22)
- Quad Food Court
- Subway
- Travel Agency
- UNSW Bookstore (E15)
- White House (C15)
- WH Smith



Category 9:
Retail & Hospitality Service Destinations

Purpose

Identify service and hospitality destinations and facilities utilised by external and internal audiences.

Note

The corresponding map code in brackets is to be paired with all campus destinations on both identification and directional sign types.

Terminology Categories

- CATS Room
- Dark Room
- Fabrication Lab
- Laboratory
- Printing Room
- Room Number
(Adopting existing UNSW numbering protocol)
- Studio
- Workshop



Category 10:
Student Facing Destinations

Purpose

Identify general-use facilities primarily used by internal audiences.

Note

Consult UNSW Project Control Group to access information regarding the existing UNSW Room Number Protocol.

Terminology Categories

- Car Park, Barker Street
- Car Park, Botany Street
- Car Park, High Street
- Car Park, Western Campus
- Male Toilet
- Female Toilet
- Unisex Toilet
- All Genders Toilet
- Male Ambulant Toilet
- Female Ambulant Toilet
- Parents Room



Category 11:
Public Service and Amenity Destinations

Purpose

Identify general-use, non-educational related facilities primarily for internal audiences.

Terminology Categories

- Staff Offices
- Meeting Rooms
- Specific functions rooms e.g. IT Purchasing
- Air Conditioning & Refrigeration
- Authorised Personnel Only
- Building Services
- Cleaners Room
- Communications Room
- Dangerous Goods Store (F17A)
- Danger Switch
- Electrical Cupboard
- Fire Control Room
- Hydraulic Riser
- Lift Control Room
- Mail Room
- Main Distribution Board
- Mechanical Room
- No Entry
- Plant Room
- Staff Room
- Stair
- Stair Fan Room
- Store Room
- Switches
- Tea Room
- Technical Services Room
- Utility



Category 12:
BOH Staff Destinations

Purpose

Identify staff offices and BOH facilities used by staff and external maintenance users.

Note

ID sign types illustrate room number and name of facility. This listing is not exhaustive of all anticipated BOH room destinations and is a guide only.

Terminology Categories

- FIRE HOSE REEL
FIRE HYDRANT
FIRE EXTINGUISHER
- FIRE HOSE REEL
FIRE HYDRANT
- FIRE HOSE REEL
- FIRE EXTINGUISHER
- FIRE SAFETY DOOR
DO NOT OBSTRUCT
DO NOT KEEP OPEN
- FIRE HYDRANT
AND SPRINKLER BOOSTER
- COMBINED FIRE HYDRANT
AND SPRINKLER BOOSTER
- FIRE SAFETY DOOR
DO NOT OBSTRUCT
- WARNING
SLIDING FIRE DOOR
- PORTABLE
FIRE EXTINGUISHER



Category 13: **BOH Building Functions**

Purpose

Identify BOH facilities including statutory regulated fire door signage used by all occupants in emergency situations and for external maintenance users.

Note

ST sign types or messaging do not appear on any directional wayfinding signage other than door signage (ST Series).

This listing is not an exhaustive list of all statutory messaging. All required signage and messaging for ST Series should be referred to BCA and Australian standards for each situation as well as the relevant certifier for assessment.

Addressing Strategy

**Messaging Structure
(External Gate Identification)**

UNSW Logo
Gate 3
High Street

**Terminology
Category**

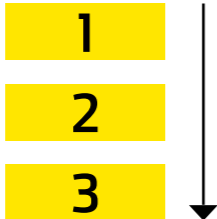

**Messaging Structure
(External & Internal Directional)**

Gate 1 & 2
Law & Justice F8
Roundhouse E6
Science and Engineering E8
Alumni Park
Fitness and Aquatic Centre B5
Toilets

**Terminology
Category**

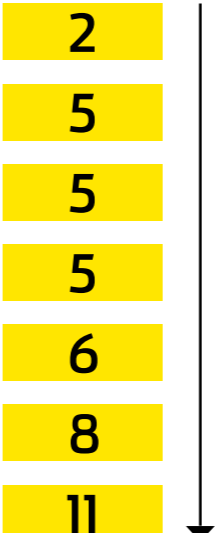

A clear and consistent addressing approach across the campus will ensure ease of navigation and roll out of signage. This will be built from current and new structures which includes the existing building naming conventions, map coding and new terminology structures.

Hierarchy

The number assigned to each category classifies its position within the messaging hierarchy (as described on the previous pages). The hierarchy is sorted by descending numerals from 0, as demonstrated in the Gate Messaging and Directory Messaging diagrams.

In instances where multiple destinations of the same category are stacked, alphabetical ordering is applied. This is shown in Directory Messaging diagram with categories '5' and '9'

Note

Refer to Section 7 Graphic Standards for additional detail on messaging hierarchy in relation to pictograms, directional arrows and statutory messaging.



Example applied to ID.05

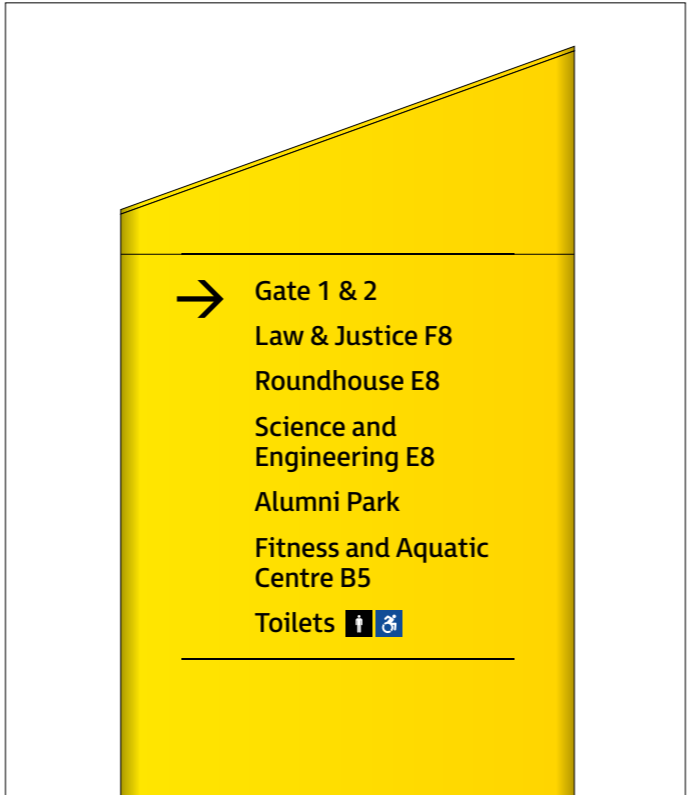

Example applied to DR.02

Signform Hierarchy

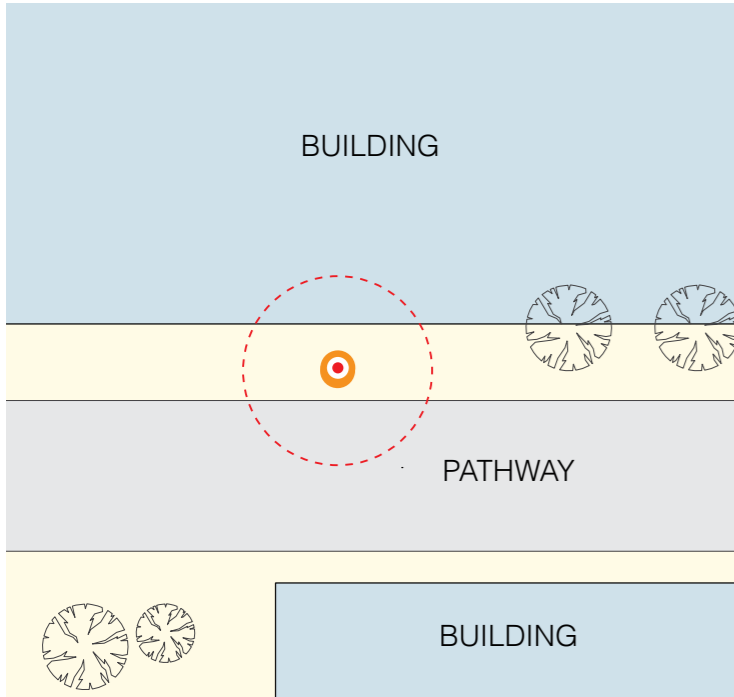

Masterplanned Decision Point

Diagrammatic location plan

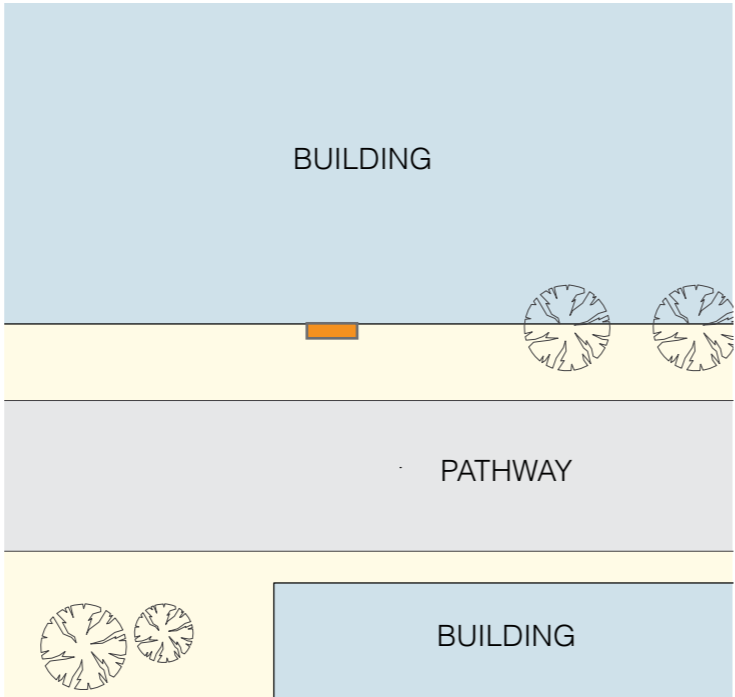

Wall Mounted Sign Selection

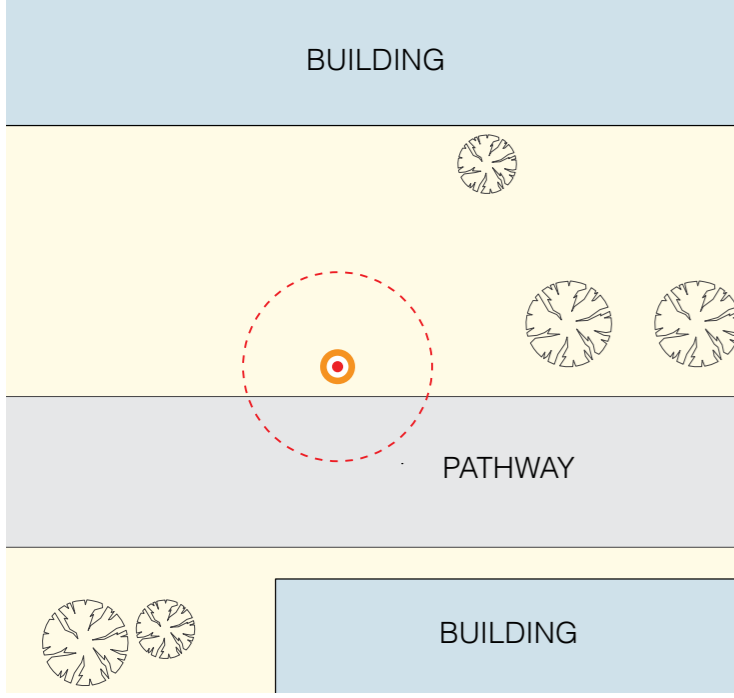

Masterplanned Decision Point

Diagrammatic location plan

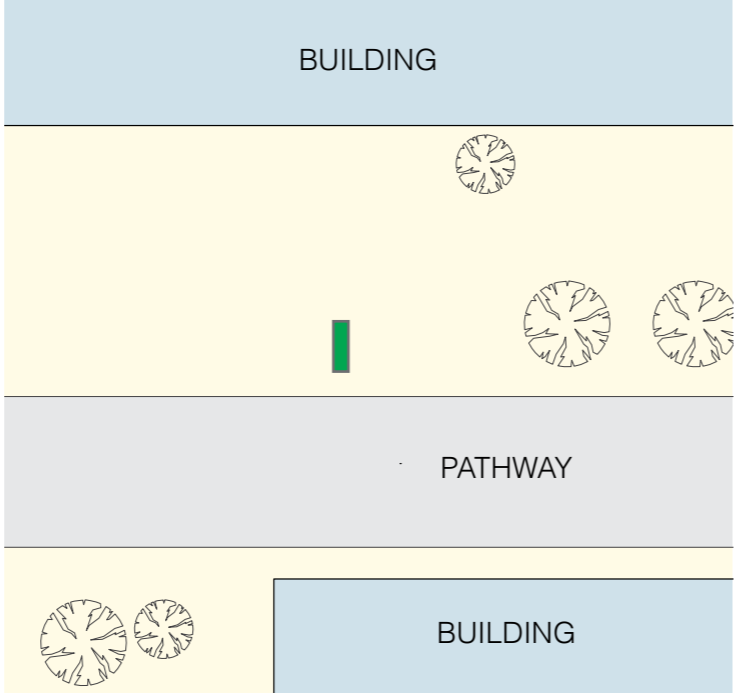

Freestanding Totem Selection

The diagrams shown illustrates the sign hierarchy protocol when determining the selection between freestanding and wall mounted signforms on a decision point that is not exclusively an open or an enclosed space.

To reduce the risk on sign saturation and ultimately implementing signforms that do not effectively respond to their environment, it is advised that a 5 metre zone is used to differentiate the suitability of a freestanding totem or wall mount sign within a location.

If a suitable wall sits within 5 metre zone of a masterplanned sign location, wall mounted signs are to be prioritised over freestanding totems.

These diagrams are a guide only and is advised that all sign locations are individually analysed to ensure that sight lines and installation processes are considered.

Sign Type Key

- DR.02 External Pedestrian Totem (2400mm)
- DR.06 Primary Wall Mounted: External Large OR DR.07 Primary Wall Mounted: External Small

Key

- Masterplanned Decision Point
- 5 Metre Zone

External Message Allocation

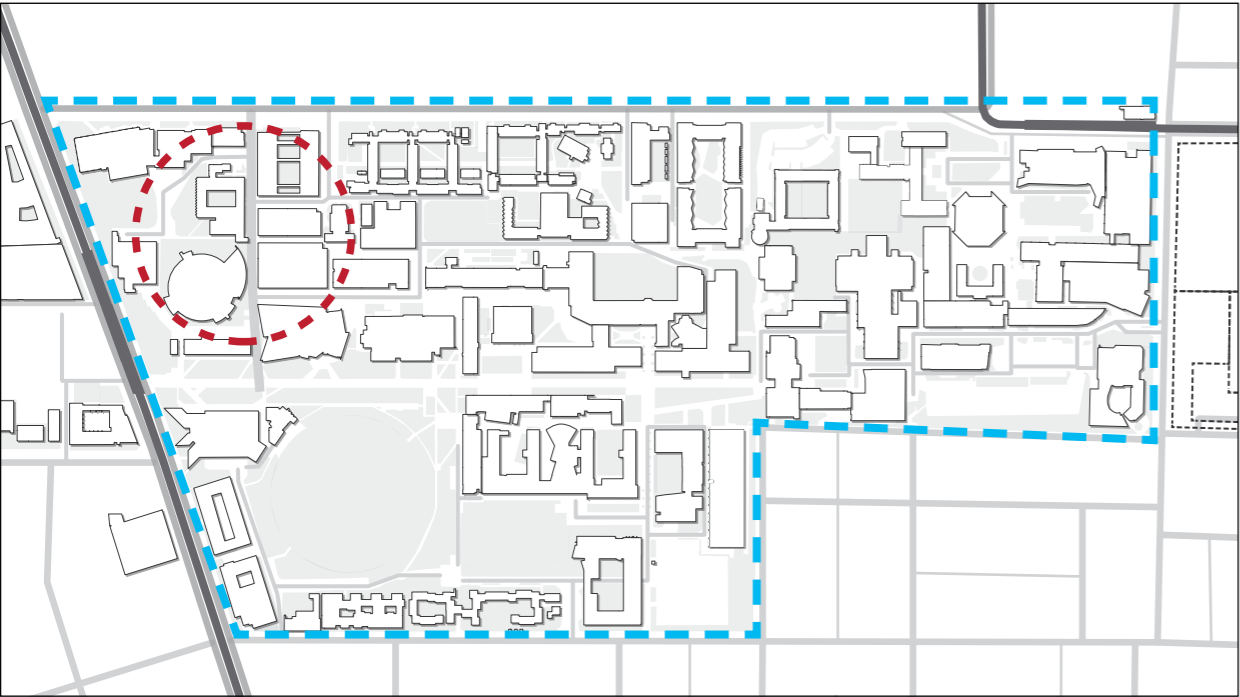

UNSW Site Plan
Scale 1:5000



200m Zone Detail
Scale 1:3000

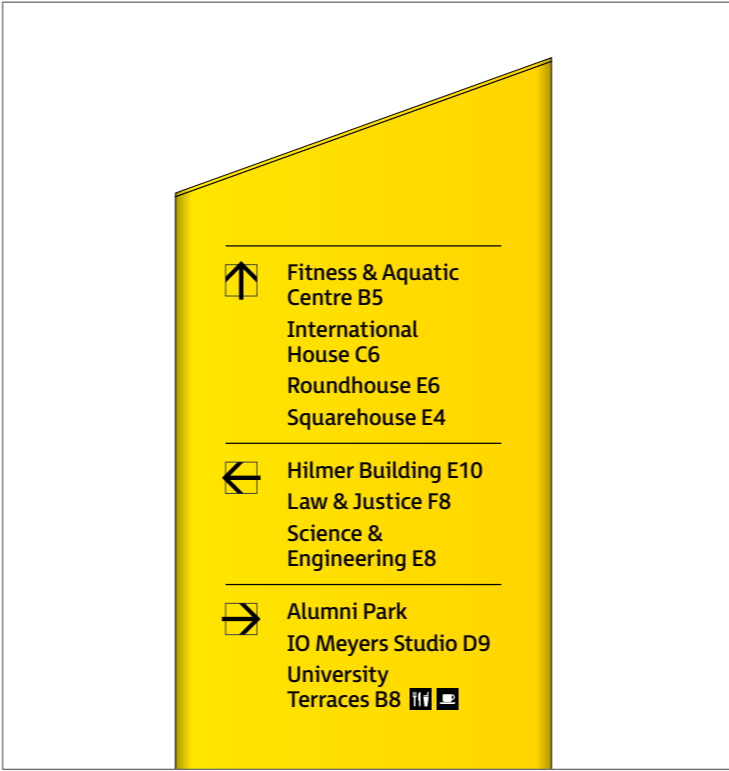

Messaging Example
Scale N/A

The diagram shown illustrates the protocol required when determining what destinations to add in an external directional sign's messaging layout, relative to its masterplanned location.

To ease the masterplanning process of external directional signs and to reduce the risk of messaging overpopulating, it is advised that a 200 metre zone is used to specify what buildings are to be directed from the location of the sign. This approach will create considered and concise wayfinding messages that are unique to each sign's location.

When individuals are seeking destinations beyond the 200m zoning of a directional sign, Digital Directory's are to provide the information that leads to the zoning of the desired destination.

These diagrams are a guide only and is advised that all sign locations are individually analysed to ensure that relevant destinations and user journeys are considered.

Specified Building Names:

- 1. Fitness and Aquatic Centre B5
- 2. University Terraces B8
- 3. International House C6
- 4. IO Meyers Studio D9
- 5. Alumni Park
- 6. Squarehouse E4
- 7. Roundhouse E6
- 8. Science and Engineering E8
- 9. Hilmer Building E10
- 10. Law & Justice F8

Key

- Masterplanned Decision Point
- 200 Metre Zone
- Digital Directory Zone
- Sign Orientation

Section

4.0

User Journey

This section identifies examples of external and internal user journeys across the Kensington Campus and in a typical faculty building.

Wayfinding Aim

External User Journey

Typical Internal User Journey

Public Accessible Destinations

Public Accessible Destinations User Journey

Wayfinding Placement

Campus Entrances

Campus Circulation

Campus Building Identification

Campus Zones

Wayfinding Aim

To provide intuitive self navigational aids to assist user journeys, a wayfinding system must:

- Use clear and consistent graphic elements which include: typeface, arrows and pictograms
- Consistent naming of routes, destinations, precincts, services and facilities
- Utilise pictograms and symbols to accompany text
- Highlight specific pathways to assist people with disability
- Provide clear signing of accessible routes where necessary

The UNSW Kensington campus is populated daily by a broad selection of users ranging from:

Campus based users consisting of the wider academic population that manages the university's many faculties, buildings and services including staff (both academic, services, and maintenance based), students (from a local, national, and international base), to users with both physical and sensory challenges.

First time/visitor base users include: potential students during orientation and other informal occasions, visiting lecturers, visitors during graduation ceremonies, as well as couriers and other service contractors.

The following pages provide three examples of external user journeys across the Kensington Campus, and one internal user experience within a faculty building.

External User Journey 1: High Street Light Rail Stop to Electrical Engineering Building F18

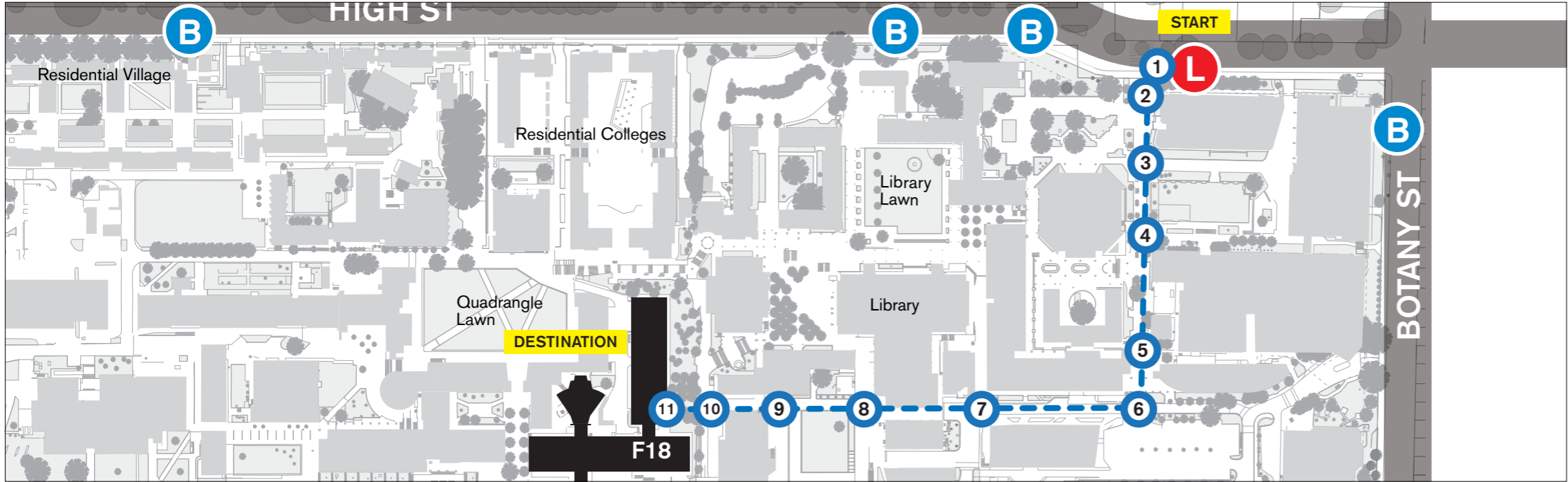

This illustrated user journey demonstrates the application of key principles and information delivery of wayfinding signage within the campus.

This journey follows a user from the proposed High Street Light Rail stop through the upper campus to the Electrical Engineering Building situated within the heart of the campus.

All wayfinding elements identified would be typically located at pathway intersections/decision points.

Diagram shown is a sample only.

1	2	3	4	5	6	7	8	9	10	11
Perimeter Campus Identification ID.02 External: Gate Secondary Vehicular Totem Family	Entry Threshold ID.09 External: Digital Directory Totem	Directional Example: DR.02 External: Pedestrian Totem 2400mm	Directional Example: DR.06 External: Primary Wall Mounted (Large)	Directional Example: DR.02 External: Pedestrian Totem 2400mm	Directional Example: DR.02 External: Pedestrian Totem 2400mm	Directional Example: DR.02 External: Pedestrian Totem 2400mm	Directional Example: DR.06 External: Primary Wall Mounted (Large)	Directional Example: DR.06 External: Primary Wall Mounted (Large)	Directional Example: DR.02 External: Pedestrian Totem 2400mm	Building Identification Example: ID.04 External: Building Facade Sign Family
High St Entry ID Precinct ID	Approaching Chancellery Walk	Between Wallace Wurth & Clancy Auditorium	Between Biological Sciences North & Northern Eatery	Between Mathews & Samuels Buildings	Intersection with Chancellery Walk	Between Mathews Building & Library	Between Library & Scientia Lawn	Between Scientia & Scientia Lawn	Intersection with Library Rd	North Electrical Engineering Building
High St Gate 9	Chancellery Walk	Chancellery Walk	Chancellery Walk	Chancellery Walk	Library Rd	Library Rd	Library Rd	Library Rd	Pathway Leading to Basser Steps	Pathway Leading to Basser Steps



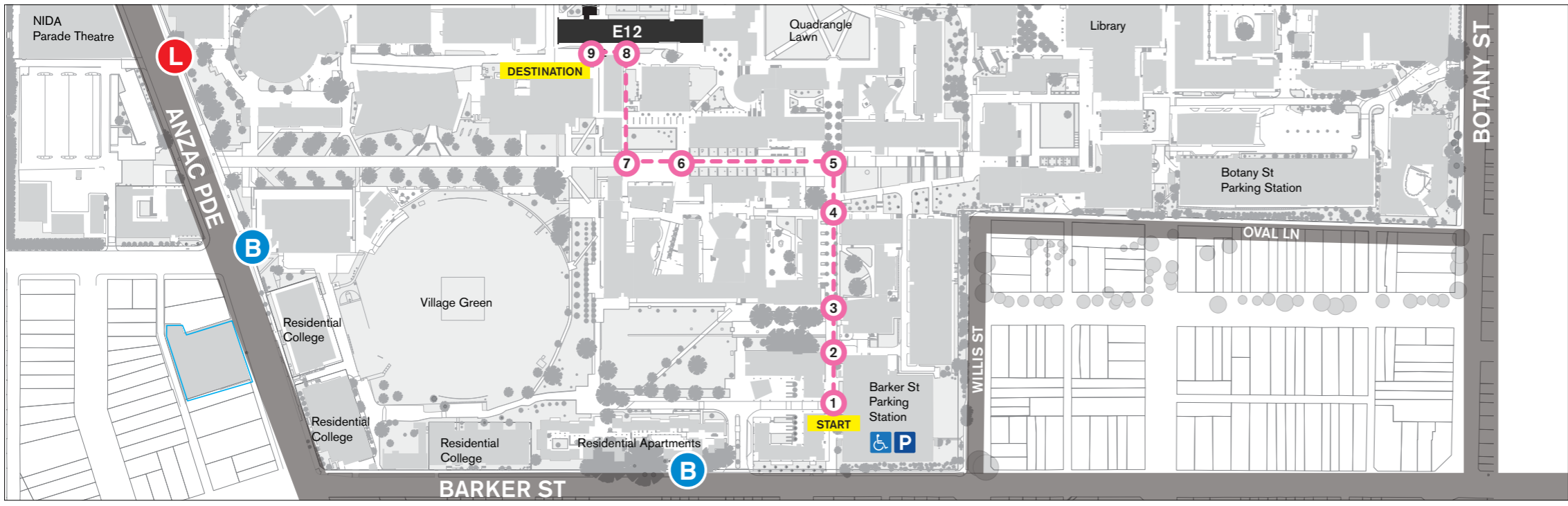





External User Journey 2: Barker Street Parking Station to Business School E12



This journey follows a user from the Barker Street Parking Station along Engineering Road intersecting with University Mall heading West to intersect with the Northern path leading to the Business School.

All wayfinding elements identified would be typically located at pathway intersections/decision points.

Diagram shown is a sample only.

<p>1</p> <p>Directional Example: DR.02 External: Pedestrian Totem 2400mm</p> 	<p>2</p> <p>Major Walkway Identification ID.05 External: Street Sign</p> 	<p>3</p> <p>Directional Example: DR.02 External: Pedestrian Totem 2400mm</p> 	<p>4</p> <p>Directional Example: DR.06 External: Primary Wall Mounted (Large)</p> 	<p>5</p> <p>Directional Example: DR.02 External: Pedestrian Totem 2400mm</p> 	<p>6</p> <p>Directional Example: DR.02 External: Pedestrian Totem 2400mm</p> 	<p>7</p> <p>Directional Example: DR.02 External: Pedestrian Totem 2400mm</p> 	<p>8</p> <p>Directional Example: DR.06 External: Primary Wall Mounted (Large)</p> 	<p>9</p> <p>Building Identification Example: ID.04 External: Building Facade Sign Family</p> 
<p>Intersection with Southern Drive</p> <p>Engineering Road</p>	<p>Intersection with Willis Lane</p> <p>Engineering Road</p>	<p>Between Building K17 & Old Main Building</p> <p>Engineering Road</p>	<p>Between Ainsworth & Lane leading to Keith Burrows Theatre</p> <p>Engineering Road</p>	<p>Intersection with Engineering Road</p> <p>Engineering Road</p>	<p>Between Science Theatre Lawn & Robert Webster Building</p> <p>University Mall</p>	<p>Between Chemical Sciences Building & Dalton Building</p> <p>University Mall</p>	<p>Between UNSW Business School Building & Dalton Building</p> <p>Building Entry</p>	<p>Entry UNSW Business School Building</p> <p>Building Entry</p>

Typical Internal User Journey

Electrical Engineering Building

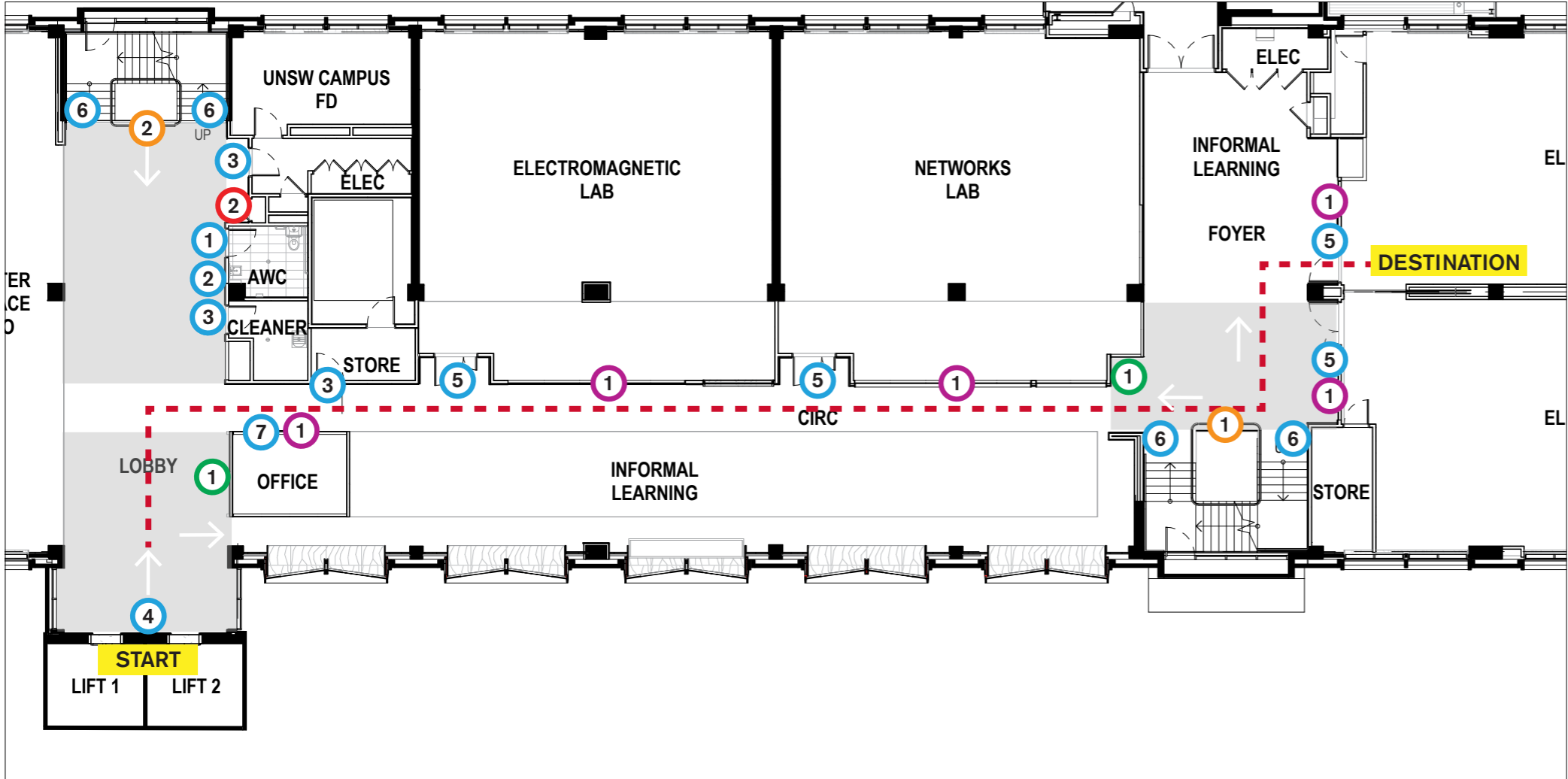

This plan identifies where different sign types should be located within a typical building's interior.

Key decision point locations are any vertical circulation points (stairs and lifts) along with main entry points.

As highlighted by the grey backgrounds, these zones are typically where a user requires two sources of information; Directory and Directional.

Directory information identifies what is located on each level, this will be implemented by either a touch screen display or static display. Directional signage directs to the main destinations, facilities and public amenities within each level.

Identification signage provides confirmation for users when reaching destinations such as rooms, utilities, and level confirmation at lifts and stair circulation points.

Statutory signage and privacy decals make up the remaining sign types typically required for a building's interior.

Directional	Directory	Identification	Statutory	Privacy
<p>1</p> <p>DR.08 Internal: Primary Wall Mounted (Large)</p>	<p>1</p> <p>ID.15 Internal: Lift Directory (Digital)</p>	<p>2</p> <p>ID.16 Internal: Lift Directory (Static)</p>	<p>1</p> <p>ID.21 Amenity Blade Family</p>	<p>2</p> <p>ST.01 Amenity Braille & Tactile Family</p>
<p>3</p> <p>ID.20b Room ID Family - Utility room</p>	<p>4</p> <p>ID.18 Internal: Lift Level ID</p>	<p>5</p> <p>ID.20h Room ID Family - Classroom with timetable</p>	<p>6</p> <p>ID.17 Internal: Stair Level ID</p>	<p>7</p> <p>ID.20e Room ID Family - Staff office</p>
<p>1</p> <p>ST.02 Fire Door Family</p>	<p>2</p> <p>ST.03 Fire Extinguisher & FHR Family</p>	<p>1</p> <p>EG.01 Privacy Graphic - Low</p>		

Public Accessible Destinations

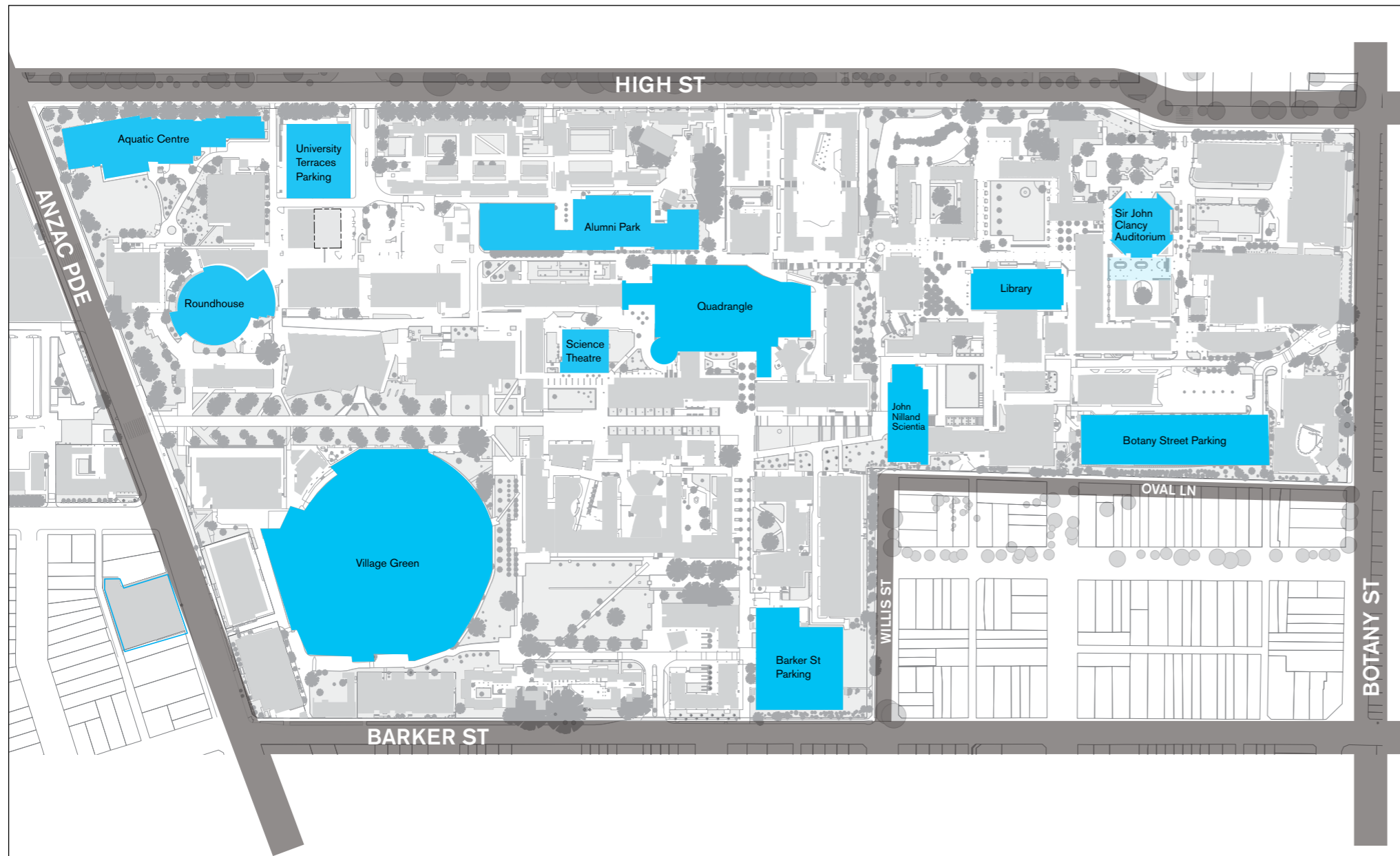

The UNSW campus currently has over seventy buildings within the precinct. The majority of buildings are used by academic personnel associated with individual faculties.

Key destinations have been identified as areas within the UNSW campus that are consistently sought by both the wider campus community and external visitors.

The Roundhouse is the campus's live music and function venue. It also houses bars and eateries.

The Science Theatre contains tiered seating for over 800 people and hosts public performances, events and concerts regularly.

The Quadrangle is considered one of the University's main student hubs containing food courts, book shops and stationery suppliers.

The surrounding area of the University Library is also considered a focal social hub with eateries located both east and west of the building.

The Sir John Clancy Auditorium, seating for over 900 people, is the largest public auditorium in the Eastern Suburbs and hosts conferences, lectures, classical music performances and recitals regularly.

Major public car parking and the Village Green spaces act as external user destinations, particular for weekend or evening sporting events.

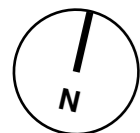

Public Accessible Destinations User Journey: Roundhouse – 1 of 2

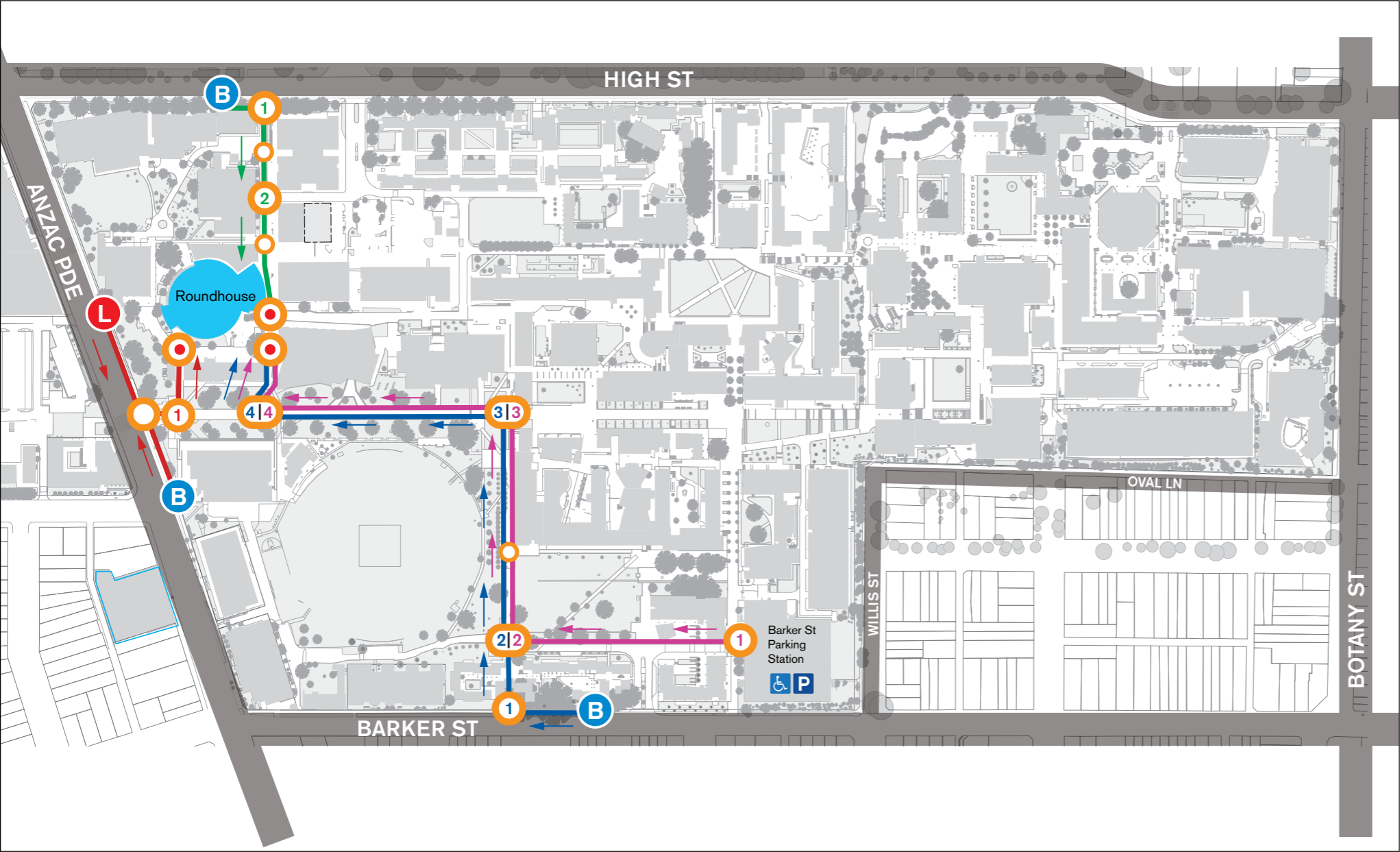

The Roundhouse has been chosen for this user journey because of its status as a live act venue for the wider Eastern suburbs community.

Four typical pedestrian paths are illustrated beginning from the following locations:

1. High Street Bus Stop;
2. ANZAC Parade Bus / Light Rail Stop;
3. Barker Street Bus Stop; and
4. Barker Street Parking Station.

Each illustrated user journey indicates the directional signage sequence for successful self navigation to the Roundhouse.

The following page outlines these touchpoints in detail.

Key

- B TfNSW Bus Stop
- L TfNSW Light Rail Stop
- ♿ Accessible Parking
- P Public Parking
- 1 Primary Decision Point with Signage
- Directional Sign Type
- ⊙ Destination
- Pedestrian Path from High St Bus Stop
- Pedestrian Path from ANZAC Parade Bus / Light Rail Stop
- Pedestrian Path from Barker Street Bus Stop
- Pedestrian Path from Barker Street Parking Station



Public Accessible Destinations User Journey: Roundhouse – 2 of 2

High Street Bus Stop



International Road entrance	International Road / Third Avenue intersection
ID.01 External: Gate Primary Vehicular Totem	Directional Sign Type Example: DR.02 External: Pedestrian Totem 2400mm, directing south

Barker Street Bus Stop



Science Road entrance	Science Road / Southern Dr intersection	Science Road / University Mall intersection	University Mall Roundhouse & Law Building
ID.03 External: Gate Pedestrian Totem Family	Directional Sign Type Example: DR.02 External: Pedestrian Totem 2400mm, directing north	Directional Sign Type Example: DR.02 External: Pedestrian Totem 2400mm, directing west	Directional Sign Type Example: DR.02 External: Pedestrian Totem 2400mm, directing north

Barker Street Parking Station



Science Road / Engineering Rd intersection	Science Road / Southern Drive intersection	Science Road / University Mall intersection	University Mall Blockhouse & Law Building
Directional Sign Type Example: DR.02 External: Pedestrian Totem 2400mm, directing north	Directional Sign Type Example: DR.02 External: Pedestrian Totem 2400mm, directing north	Directional Sign Type Example: DR.02 External: Pedestrian Totem 2400mm, directing west	Directional Sign Type Example: DR.02 External: Pedestrian Totem 2400mm, directing north

Public Accessible Destinations User Journey: Sir John Clancy Auditorium – 1 of 2

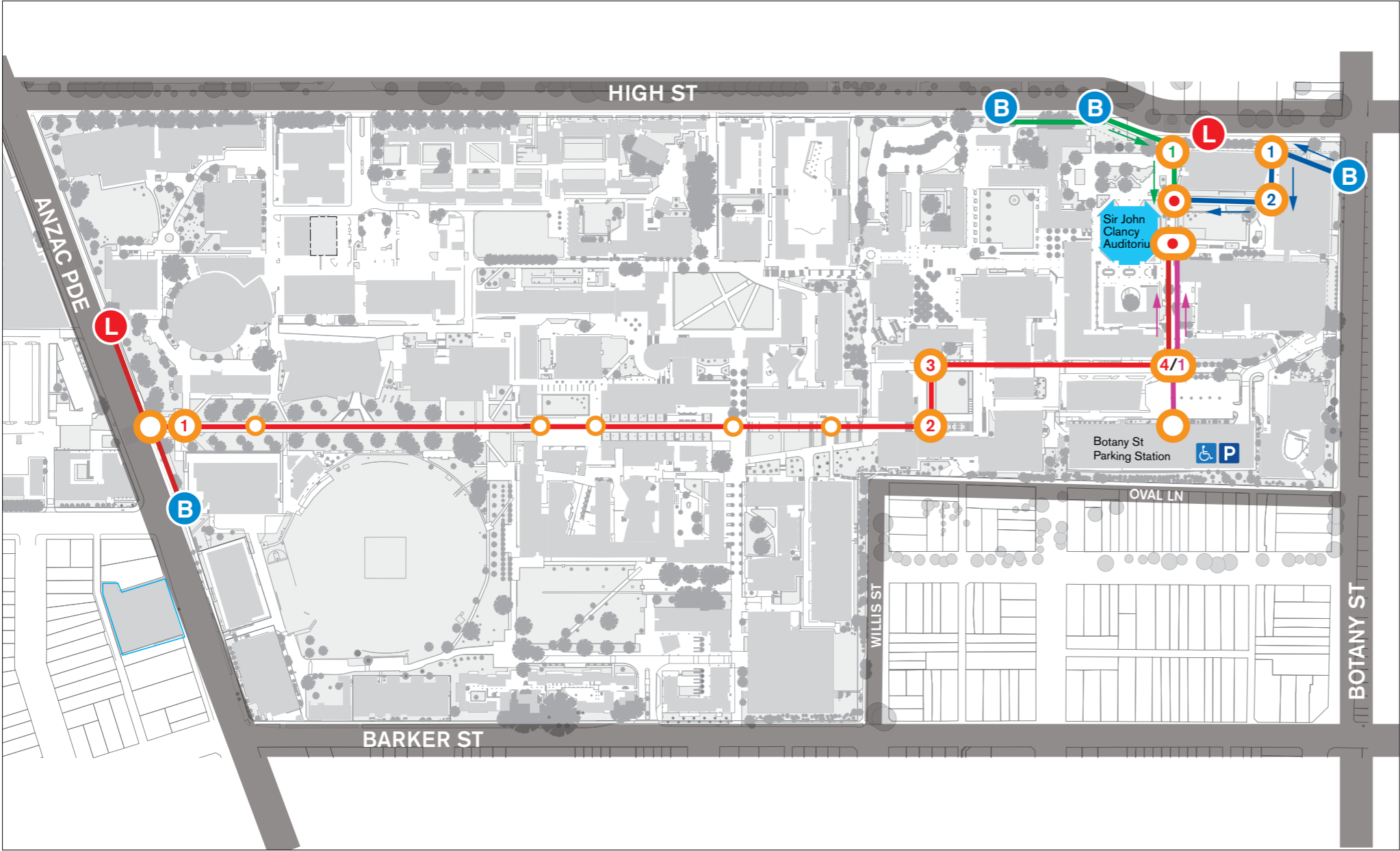

The Sir John Clancy Auditorium has been chosen for this second user journey example due to its status as the largest seating capacity auditorium within the wider Eastern Suburbs and for its function during graduation events.

Four typical pedestrian paths are illustrated beginning from the following locations:

1. High Street Bus Stop;
2. ANZAC Parade Bus / Light Rail Stop;
3. Botany Street Bus Stop; and
4. Botany Street Parking Station.

Each illustrated User Journey indicates directional signage sequence for successful self navigation to the Sir John Clancy Auditorium.

Key

- B TfNSW Bus Stop
- L TfNSW Light Rail Stop
- ♿ Accessible Parking
- P Public Parking
- 1 Primary Decision Point with Signage
- Directional Sign Type
- ⊙ Destination
- Pedestrian Path from High Street Bus Stop
- Pedestrian Path from ANZAC Parade Bus / Light Rail Stop
- Pedestrian Path from Barker Street Bus Stop
- Pedestrian Path from Barker Street Parking Station

Public Accessible Destinations User Journey: Sir John Clancy Auditorium – 2 of 2

Botany Street Parking Station



Library Walk / Chancellery Walk intersection

Directional Sign Type
Example:
DR.02
External: Pedestrian Totem
2400mm, directing north

High Street Bus Stop



Chancellery Walk entrance

ID.03
External: Gate Pedestrian Totem Family

Chancellery Walk entrance

Directional Sign Type
Example:
DR.02
External: Pedestrian Totem
2400mm, directing south

Botany Street Bus Stop



High Street / Wallace Wurth Building Entry

Directional Sign Type
Example:
DR.02
External: Pedestrian Totem
2400mm, directing south

Wallace Wurth Building/pathway leading Chancellery Walk

Directional Sign Type
Example:
DR.02
External: Pedestrian Totem
2400mm, directing west

Barker Street Parking Station

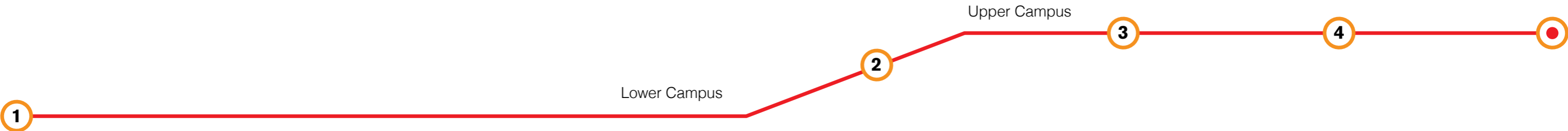

University Mall pathway

Digital Directory
ID.09
External: Digital Directory Totem, directing east

Lower Campus

Upper Campus

University Mall / Civil Engineering intersection

Directional Sign Type
Example:
ID.05
External: Street Sign, directing north

Library Road leading to Civil Engineering intersection

Directional Sign Type
Example:
DR.02
External: Pedestrian Totem
2400mm, directing west

Library Walk / Chancellery Walk intersection

Directional Sign Type
Example:
DR.02
External: Pedestrian Totem
2400mm, directing north

Wayfinding Placement

To provide intuitive navigation the following rules should be applied when positioning signage throughout the campus:

- Consistency in wayfinding signage placement
- Placement of wayfinding signage elements at major decision points
- Consider the users' navigational needs when choosing what sign type is required
- Do not over burden the user by providing too much information
- Provide information that is clear and concise
- Provide clear indicators of accessible routes where necessary

Over the following pages a number of signage positioning examples are identified as a guide for successful implementation of the wayfinding system.

It is important to remember that all signage within this package has been designed to be used in conjunction with one another, hence the terminology Wayfinding and Signage system. Consistency of positioning and messaging is critical and it is highly recommend a signage consultant is engaged to assist with the positioning and masterplanning of relevant sign types.

Campus Entrances: Vehicular Public and Authorised

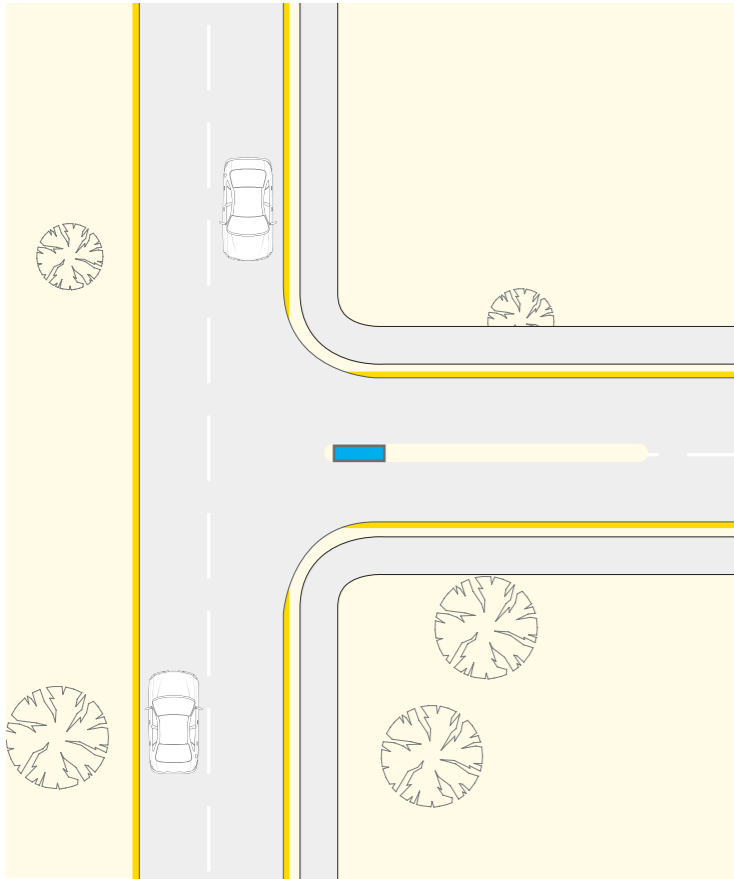

Public Vehicular Entry Locations

- Gate 2 – High Street
- Gate 11 – Botany Street
- Gate 14 – Barker Street
- Scale 1:300

**Authorised Vehicular Entry location
Ceremonial Campus Entry**

- Gate 9 – High Street
- Scale 1:300

Public Vehicular Entry Locations

As identified on the far left example, it is recommended to place an Gate Primary Vehicular Totem within the traffic island of each entrance road.

The placement within the traffic island provides equal visibility for vehicles approaching from both directions.

It also increases visibility that is reduced due to foliage surrounding the campus.

**Authorised Vehicular Entry location
Ceremonial Campus Entry**

Gate 9 High Street

The placement of a Gate Secondary Vehicular Totem within the western traffic island at the Chancellery Walk vehicular entrance identifies the secondary vehicle access routes at this location.



It also increases visibility that is reduced due to foliage surrounding the campus.

For all instances, the totem should be positioned to ensure it is clear of large vehicle turning radius.

Note Regarding Services

If any signage has the potential to obstruct campus services around entry points, such as lighting or cables, the signage should be relocated to the sides of the driveway. To be assessed on site prior to fabrication and installation.

Sign Type Key

-  ID.01 External: Gate Primary Vehicular Totem
-  ID.02 External: Gate Secondary Vehicular Totem Family

Campus Entrances: Pedestrian

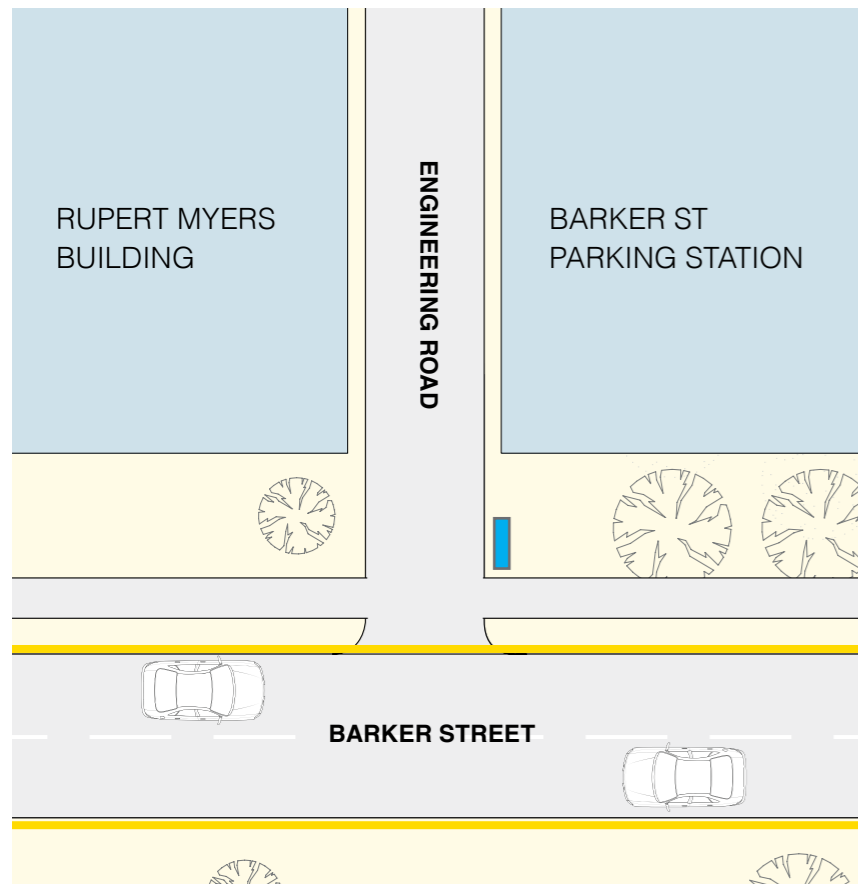

Primary Campus Entry

Barker Street & Engineering Road
Scale 1:300

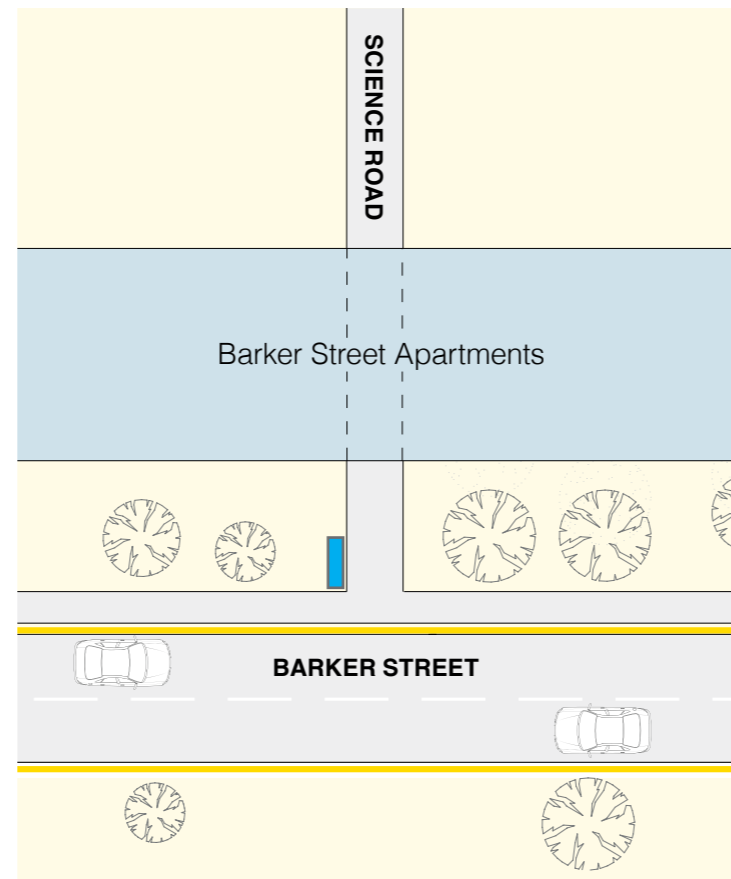

Primary Campus Entry

Barker Street & Science Road
Scale 1:300

Primary Campus Entry

Barker Street & Engineering Road

The placement of the Gate Pedestrian Totem is to allow for maximum visibility along Barker Street's footpath. It is to be located on either the western or eastern edge of Engineering Road, again this is due to the possible use of the Engineering Road entrance for emergency vehicle access.

It is recommended that placement is within approximately 1000mm from the junction of the Barker Street's footpath and Engineering Road on landscaping. Positioning should not impede pedestrian traffic on footpath. Visibility should not be obstructed by foliage surrounding the campus. This will have an impact on exact signage location.

Primary Campus Entry

Barker Street & Science Road

A major pedestrian entry point not currently identified is through the passageway under Barker Street Campus Apartments. It is recommended to identify this entrance with Gate Pedestrian Totem as the passageway leads to Science Road, one of the campus' primary circulation routes.

It is recommended that is within approximately 500mm from the junction of the Barker Street's footpath and the footpath leading through the passageway under Barker Street Campus Apartments to Science Road on landscaping. Positioning should not impede pedestrian traffic on footpath.

Visibility should not be obstructed by foliage surrounding the campus. This will have an impact on exact signage location.

Sign Type Key

 ID.03 External: Gate Pedestrian Totem Family

Campus Circulation: Pedestrian

1 of 2

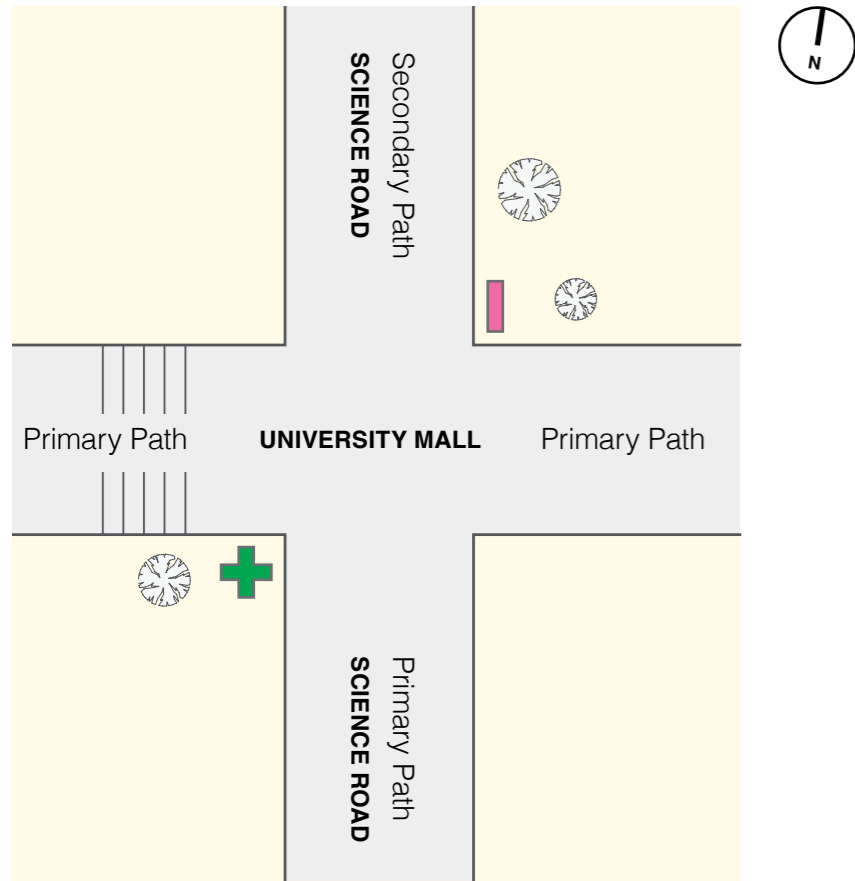

Primary Campus Circulation

University Mall & Engineering Road
Scale N/A

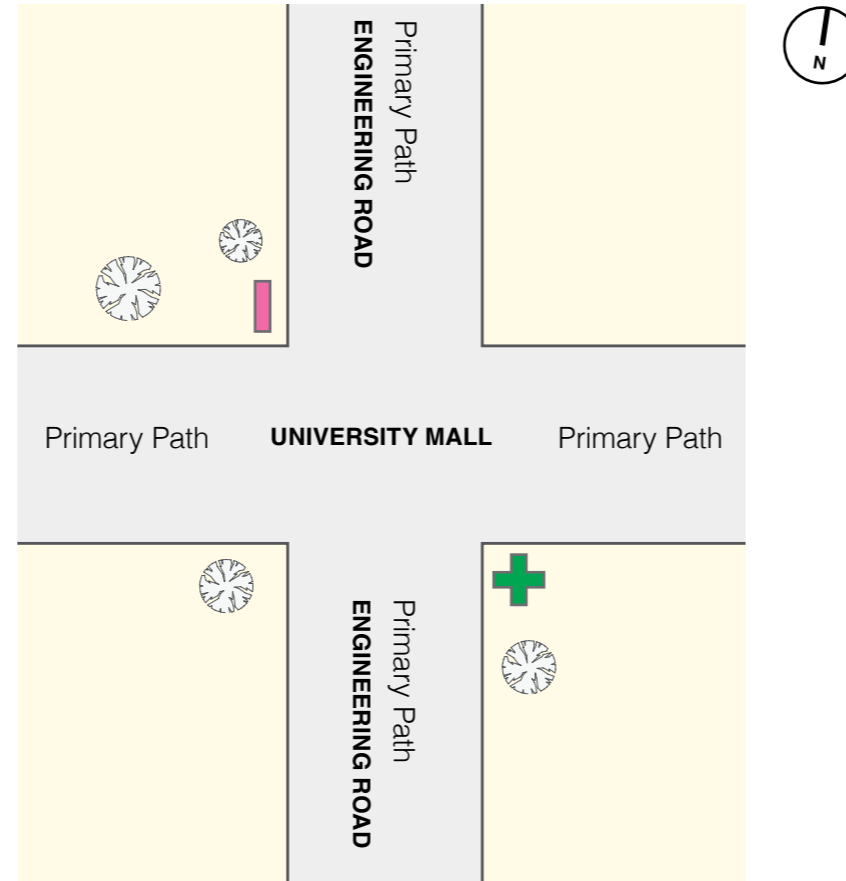

Primary Campus Circulation

University Mall & Science Road
Scale N/A

Primary Campus Circulation

Wherever primary pedestrian circulation paths intersect, the following guidelines are to be followed:

Pedestrian Totems are to be located on the northern edge of University Mall. This is due to the centre of the Campus being north of the Mall.

Pedestrian Totems are to be located within 1m from the intersection on landscaping. Positioning should not impede pedestrian traffic on footpath.

Street Signs are to be located diagonally opposite Pedestrian Totems. There are areas along University Mall that area wider than 10 metres. In this situation where '+' intersections occur mainly intersections with Science and Engineering Roads, two Street Signs can be used at both intersection points.

Where steps are near pedestrian path intersections totems are to be located on the far side of the intersection.

Sign Type Key

 DR.02 External: Pedestrian Totem (2400mm)

 ID.05 External: Street Sign

Campus Circulation: Pedestrian

2 of 2

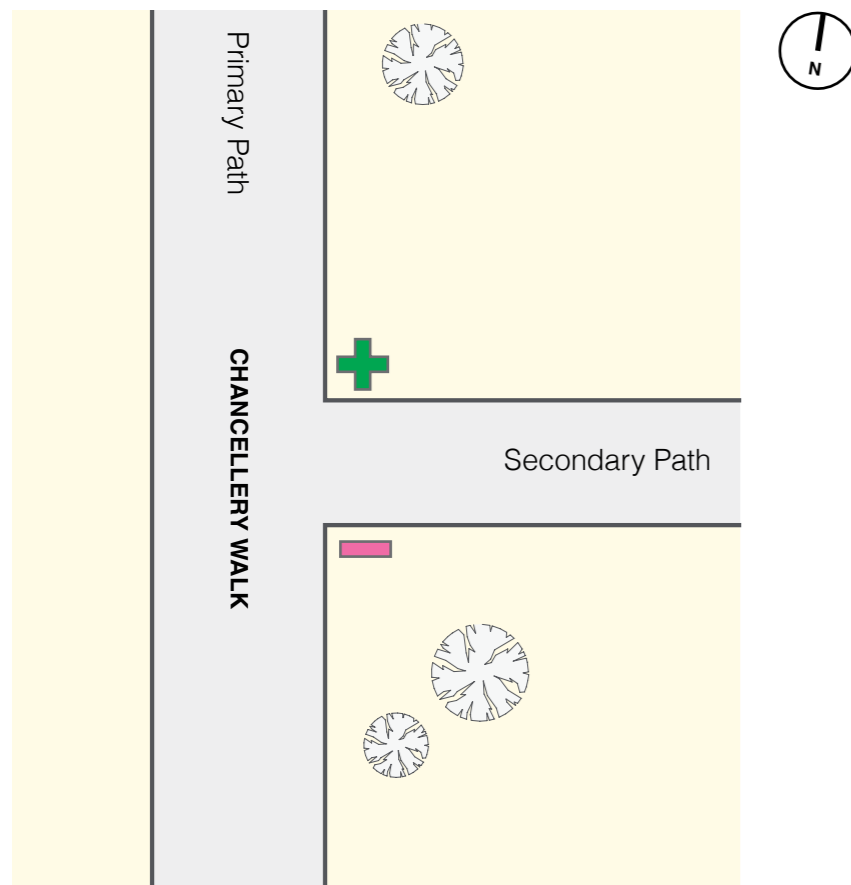

Campus Circulation Paths intersection

Chancellery Walk & secondary path intersection
Scale 1:300

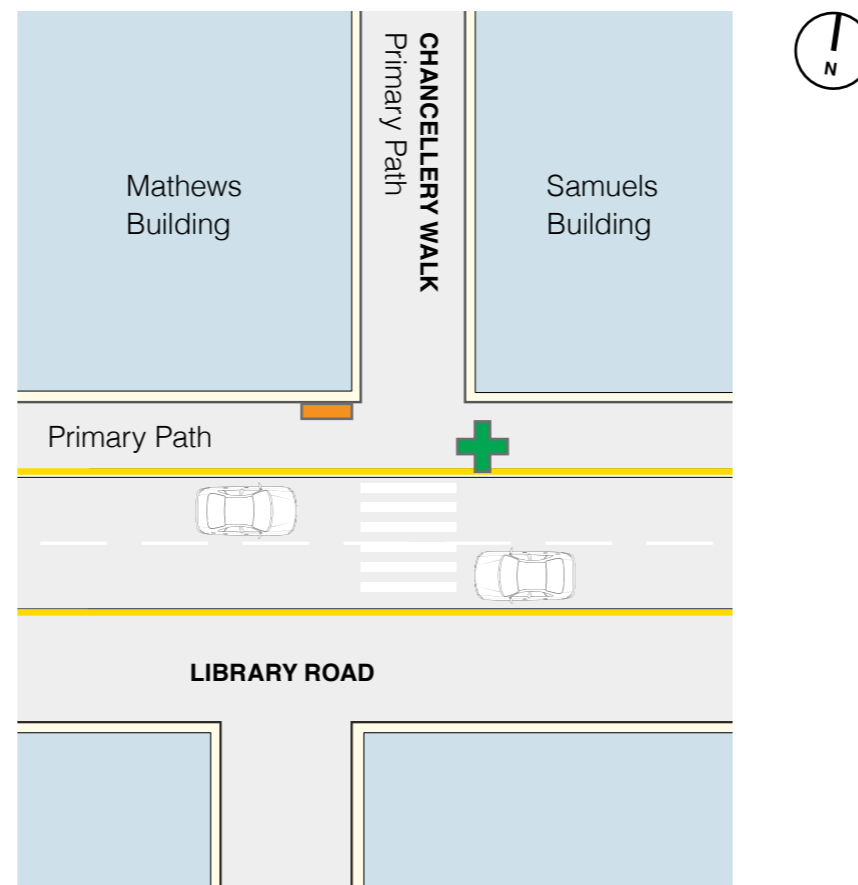

Primary Campus Circulation - Restricted Spaces

Library Walk & Chancellery Walk
Scale 1:300

Campus Circulation Paths intersections

When two pedestrian circulation paths of different categories intersect (see section 2), the following guidelines are to be followed:

The Pedestrian Totem sign type is to be placed on the higher circulation category (see section 2).

Pedestrian Totems are to be located within 1m from the intersection with other paths on landscaping. Positioning should not impede pedestrian traffic on footpath.

Street Signs are to be located diagonally opposite Pedestrian Totems.

Where steps are near pedestrian path intersections totems are to be located on the far side of the intersection.

Primary Campus Circulation – Restricted Spaces Library Walk & Chancellery Walk

Library Walk footpath is an example where two primary circulation paths intersect within a restricted space. The placement of a Pedestrian Totem is not possible here, so a Primary Wall Mounted sign type is to be used. The exact location is to be determined on site however it is important to ensure the location is clear of other notices or obstructions to provide prominence and ease of viewing.

Street Signs are to be located at the end point of the 'T' junction as indicated.

Sign Type Key

-  DR.02 External: Pedestrian Totem (2400mm)
-  DR.06 External: Primary Wall Mounted (Large) OR DR.07 External: Primary Wall Mounted (Small)
-  ID.05 External: Street Sign

Campus Building Identification

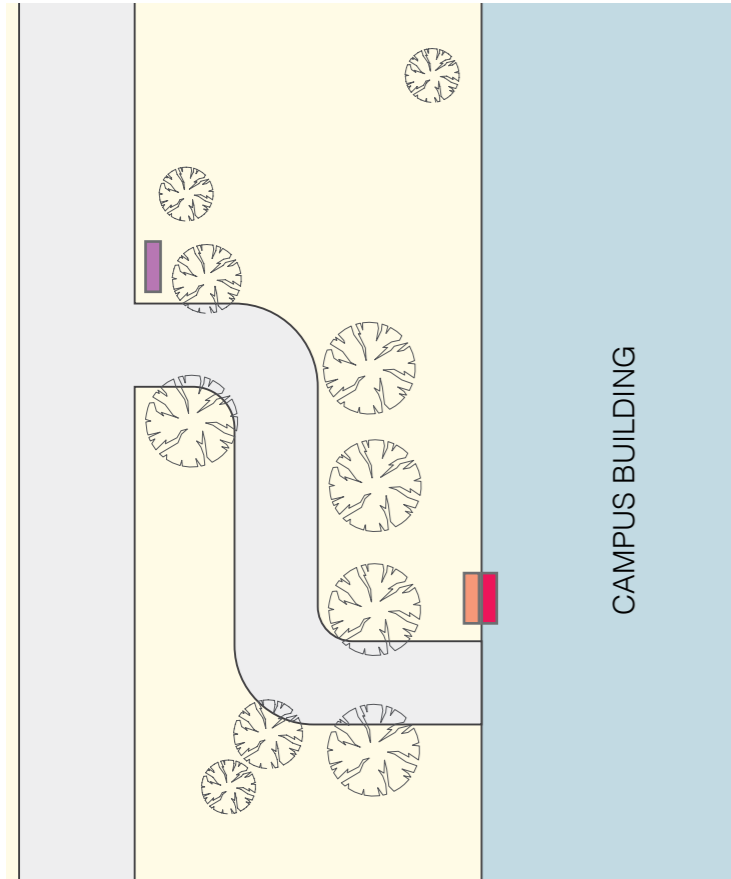

Campus Building located away from Major Pedestrian Circulation path - Example 1

Scale N/A

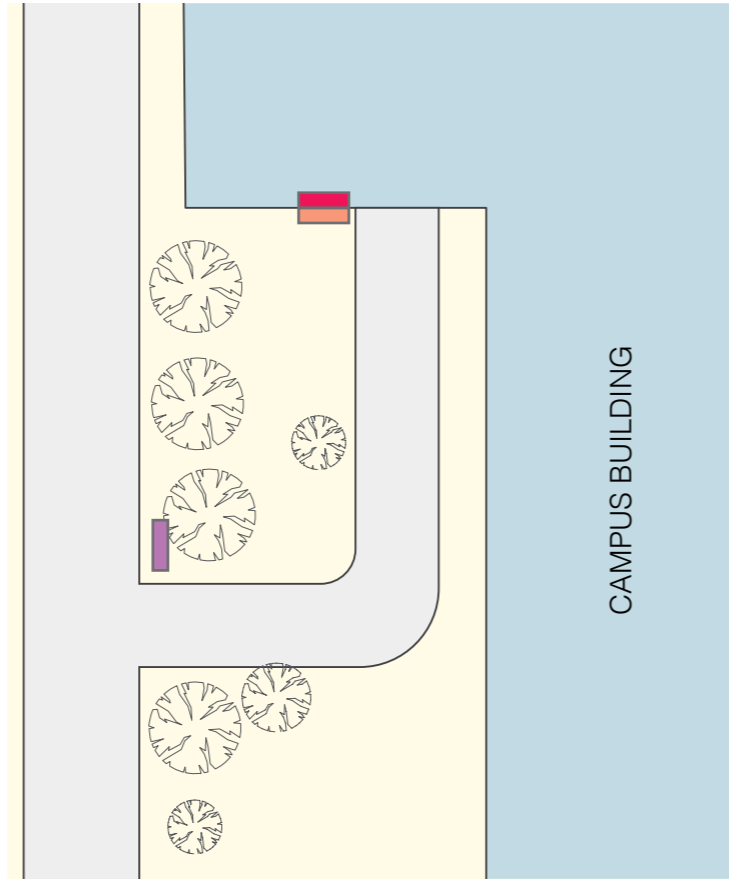

Campus Building located away from Major Pedestrian Circulation path - Example 2

Scale N/A

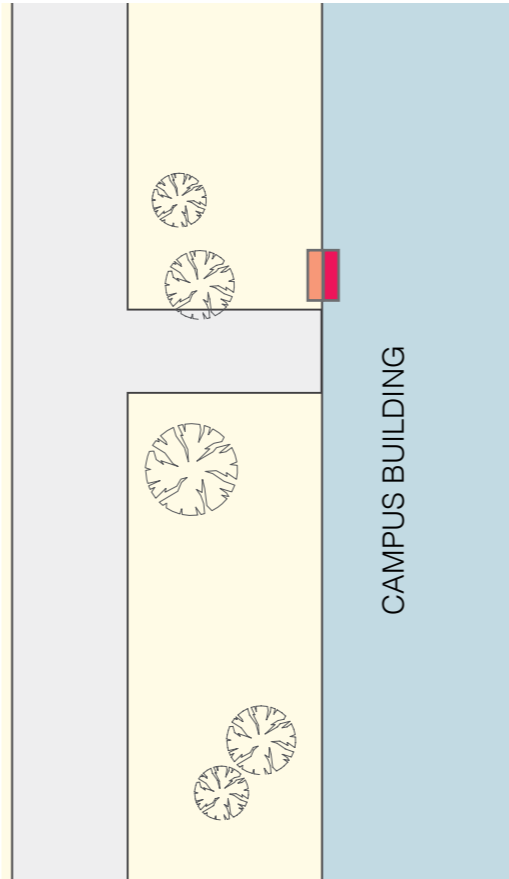

Campus Building located directly on Major Pedestrian Circulation paths Example 3

Scale N/A

Example 1 & 2

Campus Building located away from a Major Pedestrian Circulation path

Three forms of identification are required when a building entrance is located away from a major Pedestrian Circulation Path and cannot be visually seen:

Building Entrance Totem which is placed at the junction point between the Major circulation path and pedestrian service path leading to the building itself.

Building Entrance Wall-Mounted located at the entrance to the building.

Building Facade Sign Family individual letters are to be mounted on the most appropriate location close to the building's entrance to allow maximum identity.

Example of this situation is Willis Annex off University Square.

**Example 3
Campus Building located directly on Major Pedestrian Circulation paths**

Only two forms of identification are required when a building entrance can be seen directly from a major Pedestrian Circulation Path:

Building Entrance Sign located at the entrance to the building.

Building Facade Sign Family individual letters are to be mounted on the most appropriate location close to the building's entrance to allow maximum visibility, this may include the side of the building as well as approaching from University Mall (confirm with architect).

In all situations consistency is required.

Sign Type Key

- ID.04 External: Building Facade Sign Family
- ID.06 External: Building Entrance Totem
- ID.07 External: Building Entrance Wall-Mounted

Campus Zone example: Pedestrian

1 of 4

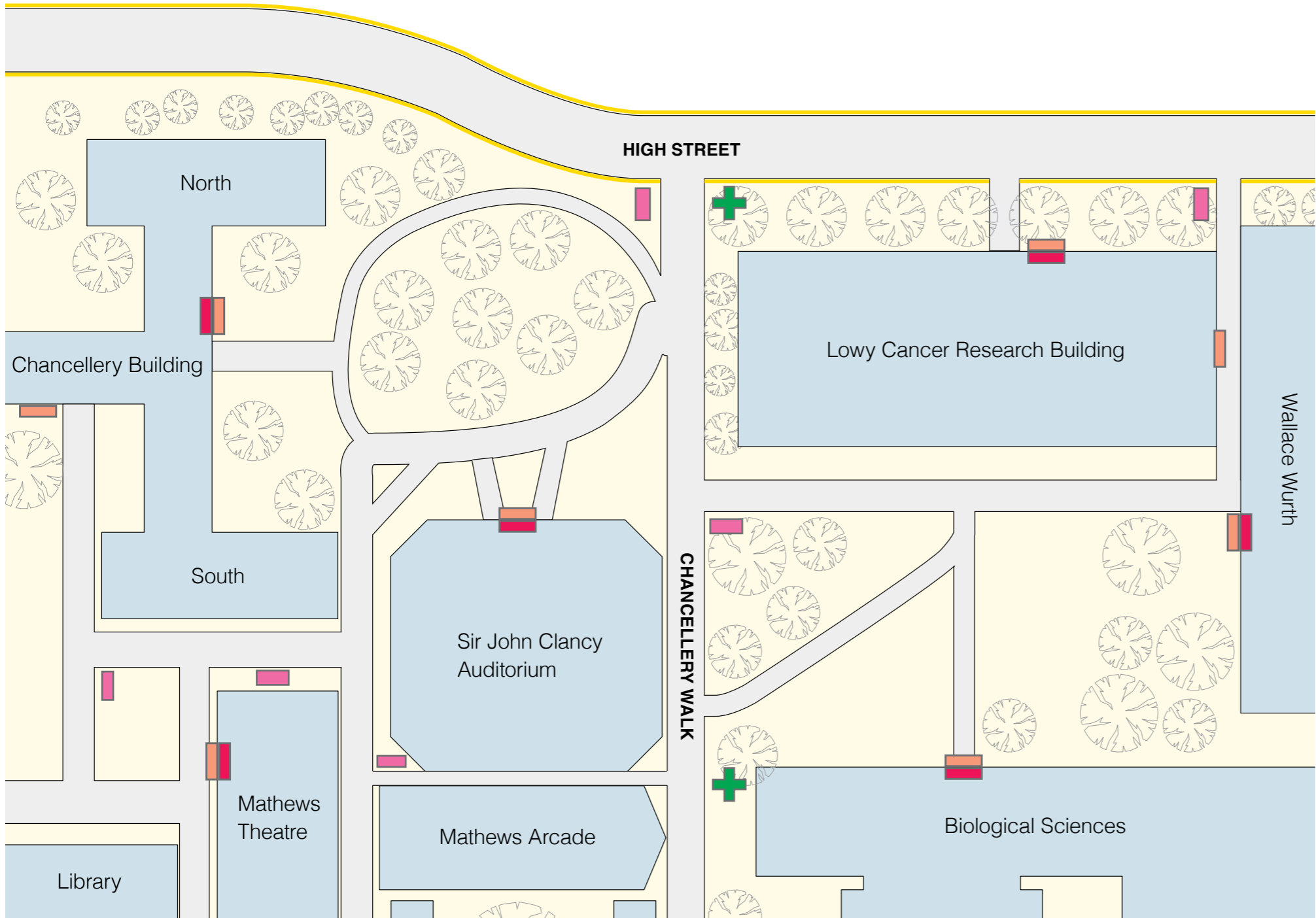

Section of North East Upper Campus
Scale N/A

Ceremonial Zone within the Campus

Chancellery Walk

Illustrated is a general guide for the placement of the main wayfinding elements used to provide self navigation within the North-Eastern corner of the campus.

Note all directional totems are placed within the path's side closest to the campus' centre.

Location Key

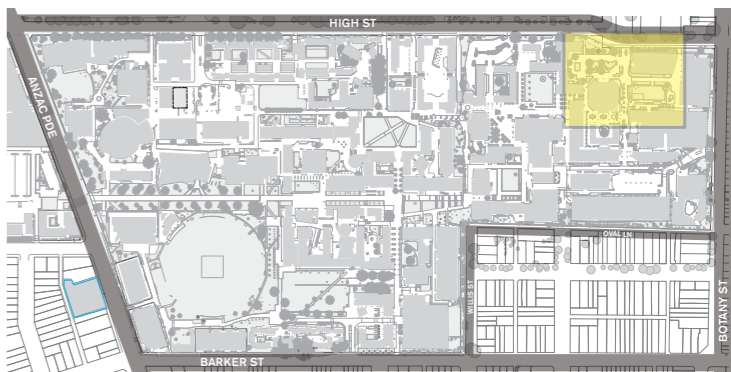

Sign Type Key

- DR.02 External: Pedestrian Totem (2400mm)
- ID.04 External: Building Facade Sign Family
- ID.05 External: Street Sign
- ID.06 External: Building Entrance Totem
- ID.07 External: Building Entrance Wall-Mounted

Campus Zone example: Pedestrian

2 of 4

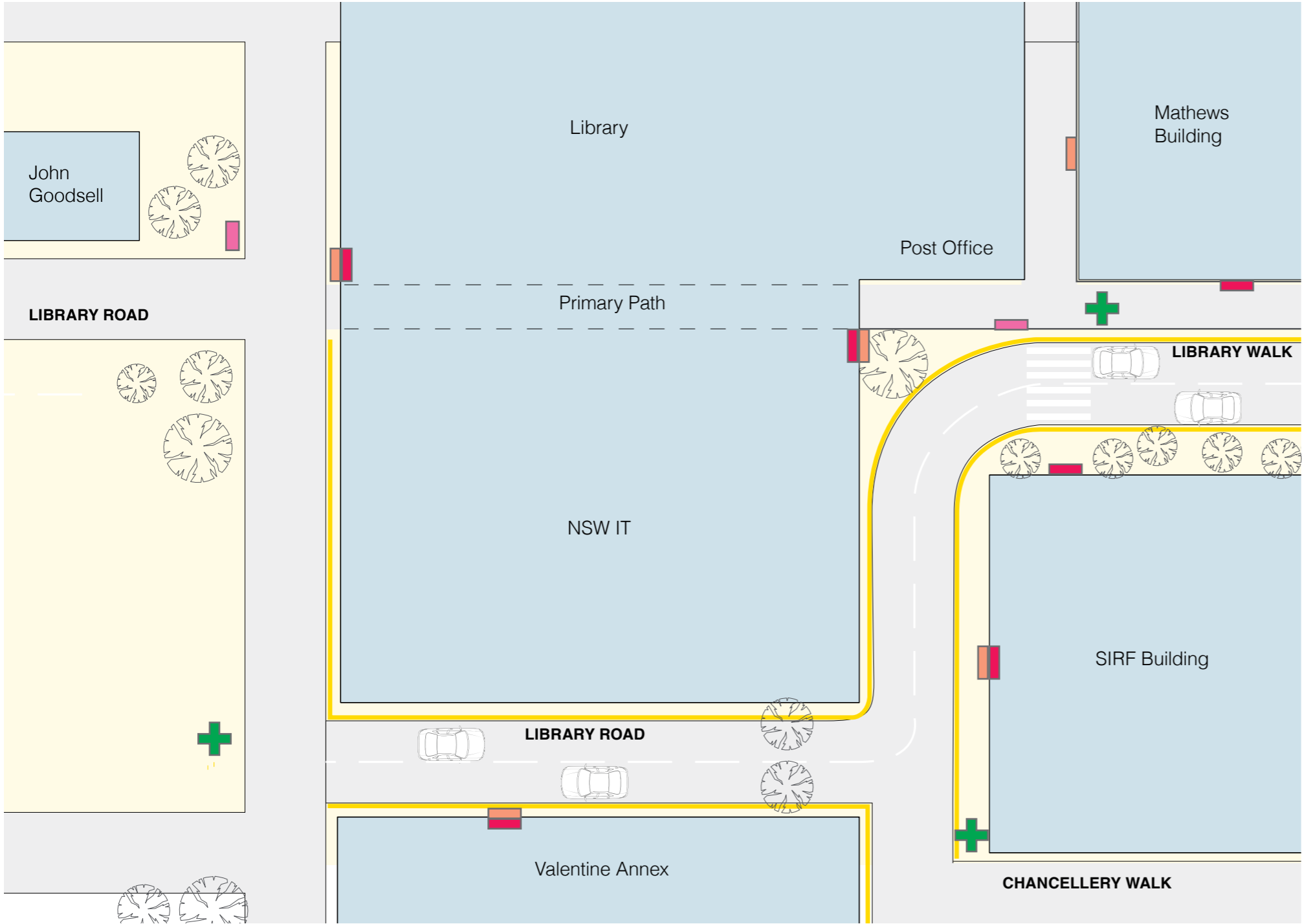



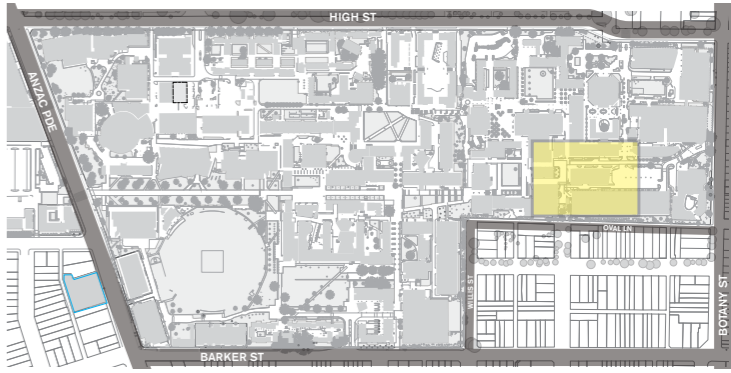

Section of West Upper Campus
Scale N/A

Ceremonial Zone within the Campus
Note all directional elements are placed within the path's side closest to the campus' centre.

Location Key



Sign Type Key

-  DR.02 External: Pedestrian Totem (2400mm)
-  ID.04 External: Building Facade Sign Family
-  ID.05 External: Street Sign
-  ID.06 External: Building Entrance Totem
-  ID.07 External: Building Entrance Wall-Mounted

Campus Zone example: Pedestrian

3 of 4

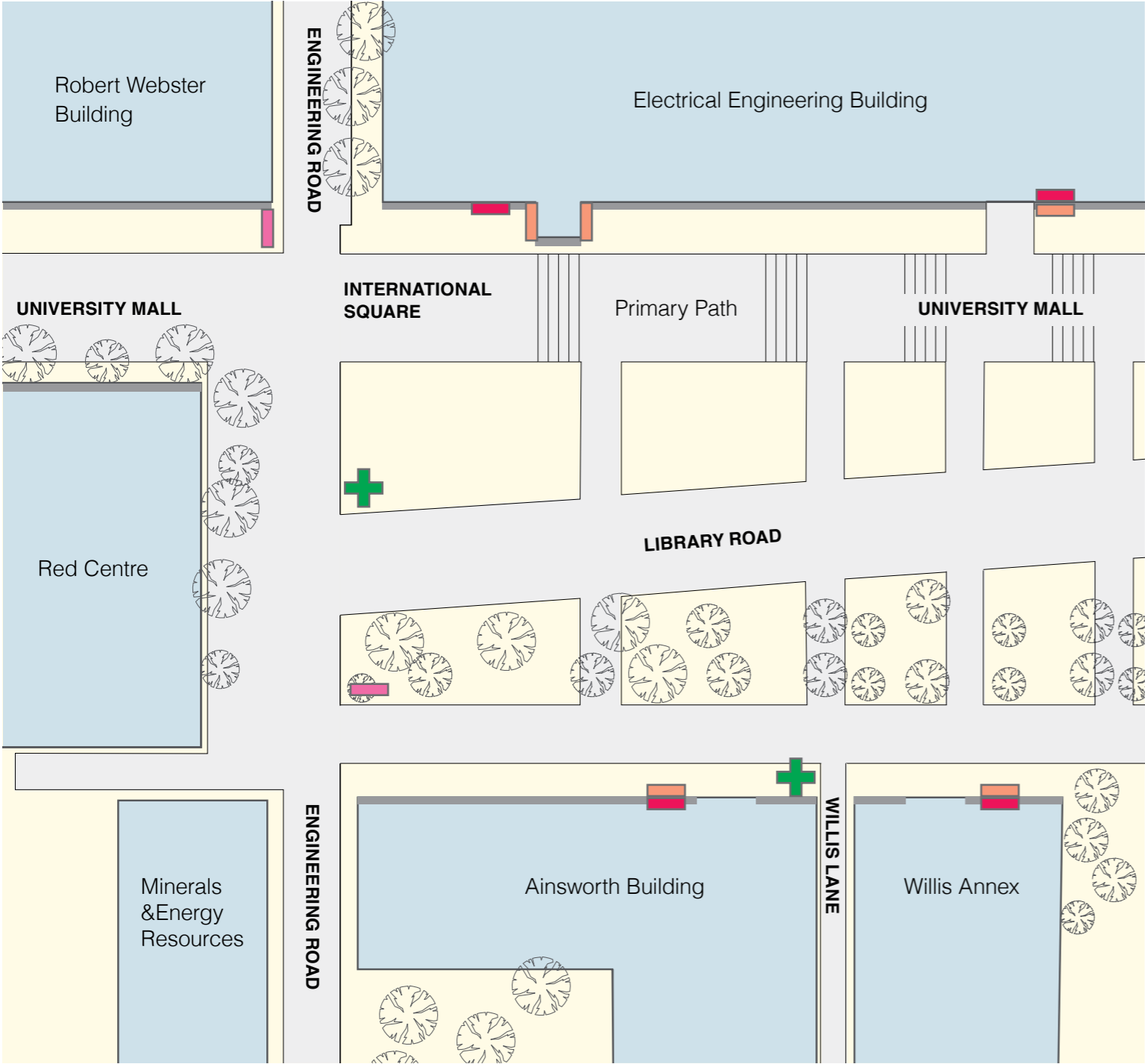

Section of West Lower Campus
Scale N/A

International Square between Ainsworth and Electrical Engineering Buildings

Illustrated is a general guide for the placement of the main wayfinding elements used to provide self navigation at the gradient slope within the Lower Campus Eastern Zone approaching Upper Campus.

This example highlights the use of Building Entrance Totems used to identify buildings that are not located directly on major pedestrian paths.

Location Key

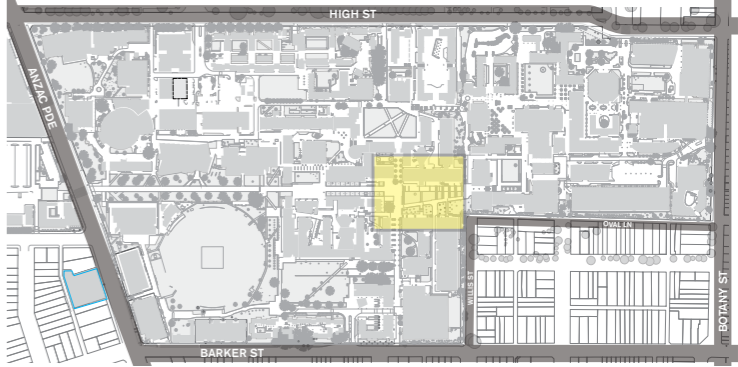

Location Key

- DR.02 External: Pedestrian Totem (2400mm)
- ID.04 External: Building Facade Sign Family
- ID.05 External: Street Sign
- ID.06 External: Building Entrance Totem
- ID.07 External: Building Entrance Wall-Mounted

Campus Zone example: Pedestrian

4 of 4

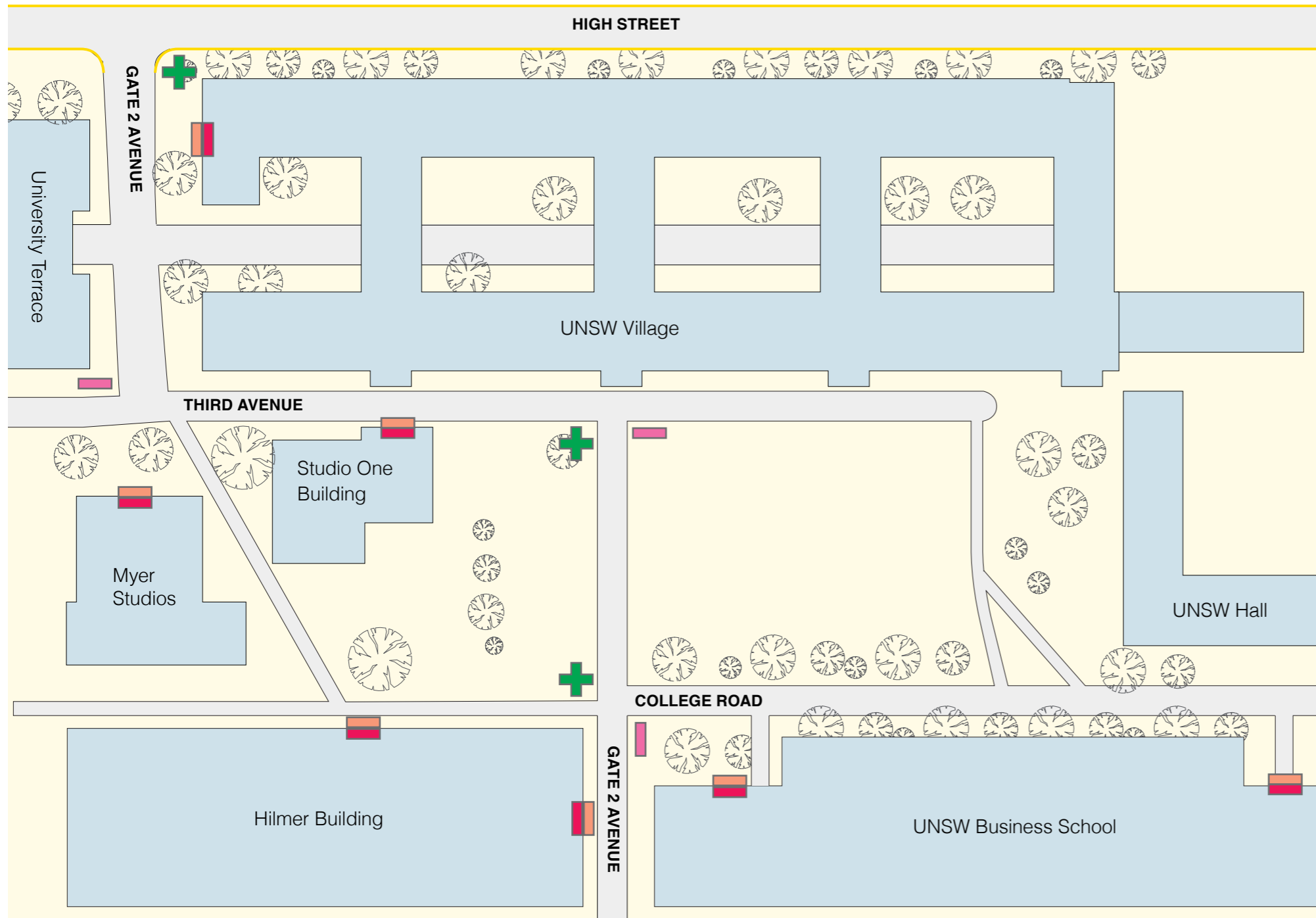

Section of North Lower Campus

Scale N/A

Gate 2 Avenue junction with College Road

Illustrated is a general guide for the placement of the main wayfinding elements used to provide self navigation from Gate 2 Avenue through to College Road.



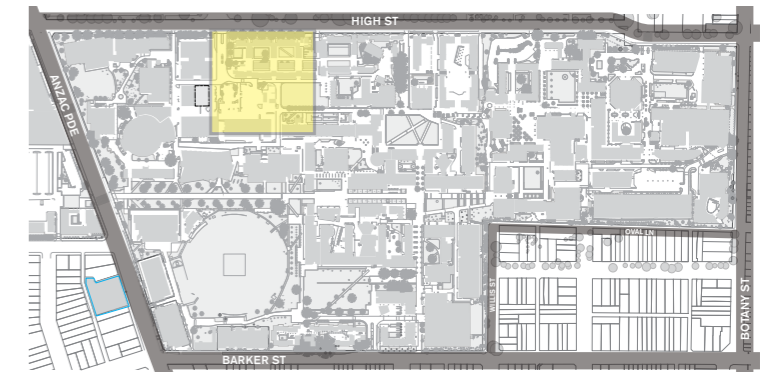

It is important to note that Gate 2 Avenue and College Road are shared vehicle and pedestrian paths.

Care has to be taken in locating signs in a manner that does not disrupt or endanger vehicle and pedestrian circulation.

Location Key



Sign Type Key

-  DR.02 External: Pedestrian Totem (2400mm)
-  ID.04 External: Building Facade Sign Family
-  ID.05 External: Street Sign
-  ID.06 External: Building Entrance Totem
-  ID.07 External: Building Entrance Wall-Mounted

Section

5.0

The Process

This section outlines the step by step process that needs to be undertaken when implementing the wayfinding system.

Wayfinding Strategy Overview

Process Overview

Process Details

Wayfinding Strategy Overview

The UNSW sign family has been developed to respond to typical wayfinding journeys for pedestrian and vehicular users approaching the campus via public transport, private vehicle and bicycle.

The sign family responds to the demands of the campus, including its size, layout and varied landscape, while also laying a strong foundation for the campus overhaul outlined in the 2025 UNSW Vision.

Hierarchical System

UNSW Kensington campus is highly concentrated within a single large block, and thus requires a hierarchical wayfinding strategy based on user journeys from external to internal. When information is given too early the user can become overloaded with information and require continual confirmation along the journey. A proliferation of signage across the site does not aid in legible wayfinding and is expensive to maintain.

The approach adopted in these Signage Standards is to develop a systematic delivery of information across the site that responds to the journey from arrival at the campus perimeter through to a building, level and final room destination. The sign family and graphic layout design is hierarchical in the sign form, sign content, font size and weight. Not all destinations can be illustrated on the signs so a descending order of importance is used to determine sign content.

The sign family also clearly delineates the perimeter of the campus and its entry points, emphasising the physical presence of UNSW while also forming an iconic visual brand for the campus.

Wayfinding Principles

The UNSW Signage Standards adhere strictly to wayfinding principles as set out in Section 23, creating a signage system that responds effectively to accessibility guidelines and ensures clarity and legibility of signs. These principles, as well as the terminologies and hierarchies put in place, ensure that the campus remains an accessible and inclusive destination for all users, including non-English speakers, disabled and first time visitors.

Terminologies

As a general rule, signage messaging adopts the current numbering systems and terminologies put in place by UNSW, in order to not disrupt the day to day processes of such a large campus. Furthermore, as the 2025 UNSW Vision consists of a significant change to campus buildings and destinations, the proposed system should allow easy integration of new destination names and codes. The system also adopts the current map grid coding already in place for building referencing, establishing relationships between built forms and their mapped locations through integration of these codes into signage messaging.

Refer to Section 3: Addressing and Terminology for a comprehensive listing of all campus destinations and their appropriate hierarchies.

Graphic Standards

A highly rigorous set of graphic standards enables the wayfinding system to be thoroughly consolidated and consistent across the campus, while becoming an iconic part of the UNSW identity. Furthermore, the use of UNSW yellow as the main signform colour ensures a high level of contrast and legibility in campus environments.

Modular System

The UNSW sign family is also highly modular, consolidating many existing disparate sign types into sign type families that can be easily assembled and installed to suit the purposes of each destination. The majority of sign forms have been designed to allow the removal and replacement of panels, allowing for updates or amends to easily be made. Furthermore, room identification sign types have been designed as a stacking system that respond to the function and necessity of each room.

Process Overview



The Signage Standards will be utilised for replacing an existing sign due to content changes due to re-planning or damage and also new sign implementation programs for new or refurbished buildings. The process remains the same for one sign or one hundred signs. Outlined here is a stepped process identifying the stages of planning for implementing signs, who is responsible for each step, and critical approval points. This is further detailed in the following pages.

Note: Steps 13 and 14 relevant to large projects only.

- YELLOW** boxes indicate where UNSW and/or a nominated Signage Consultant carries out the work.
- GREY** boxes indicate where the Signage Contractor is responsible for carrying out the work. This process is a guide only, based on industry experience and the existing signage installation.
- WHITE** boxes show where the Signage Consultant or the Signage Contractor share responsibility to deliver the work.

Step 1: Audit

Review the site and identify what signs / panels are required based on site function / facilities, key destinations and circulation routes. Use this process to become accustomed to the building and its key areas that users will need to locate.

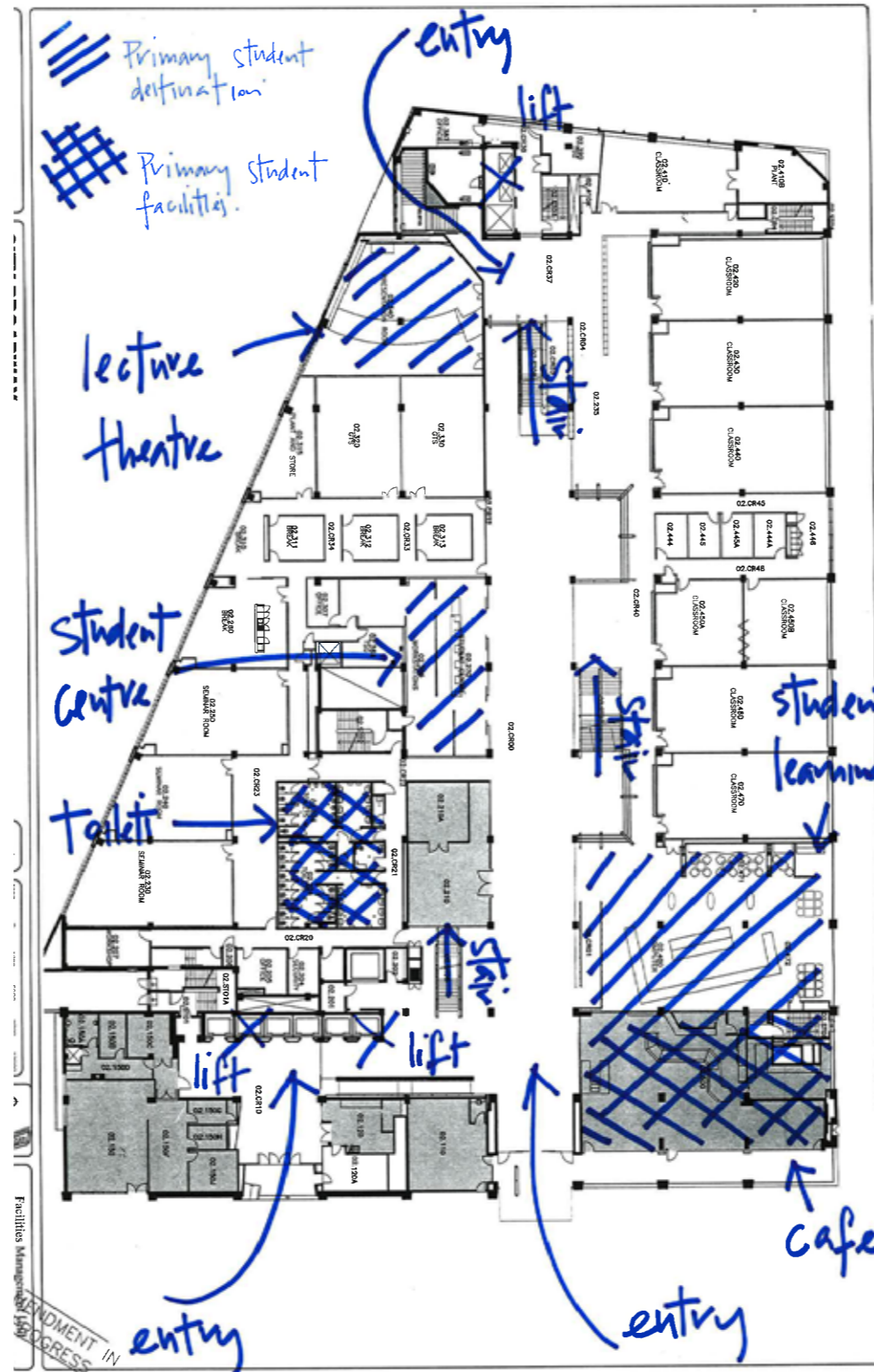

Sign Planning

While there will be a variety of users of the site, the primary user group to deliver wayfinding and identification signage for are the UNSW students.

The site and/or building function and form, its types of users and hours of operation all influence where signs are located.

Sign planning is best done by walking the site either physically for existing buildings or by reviewing the site/building plans and liaising with the site/building designers and UNSW to understand the project requirements.

Circulation Diagram

A circulation diagram indicating typical journeys for various user groups will assist in developing the sign locations. The diagram should highlight entries, locations of movement devices – lift, stair escalators and major facilities/destinations. All routes that offer more than one way to proceed will require directional signage.

Essential questions are asked: 'Which building am I entering, and what is in the building?'. 'Where do I find the lift or toilet?'. Answering questions where it is appropriate and confirming primary information along the way will develop a legible system of movement across and through the site/building. Consider the changes of use and potential management issues that may arise from site to site.

Existing Precincts

For existing sites that require refurbishment of their signage systems, adjacent precinct signage should also be considered, and may need to be amended based on the new signage system.

Step 2: Sign Locations

Indicate on site plans the location of all signs using the alpha-numeric coding established in these Signage Standards.

It is recommended a signage consultant assists with this process.

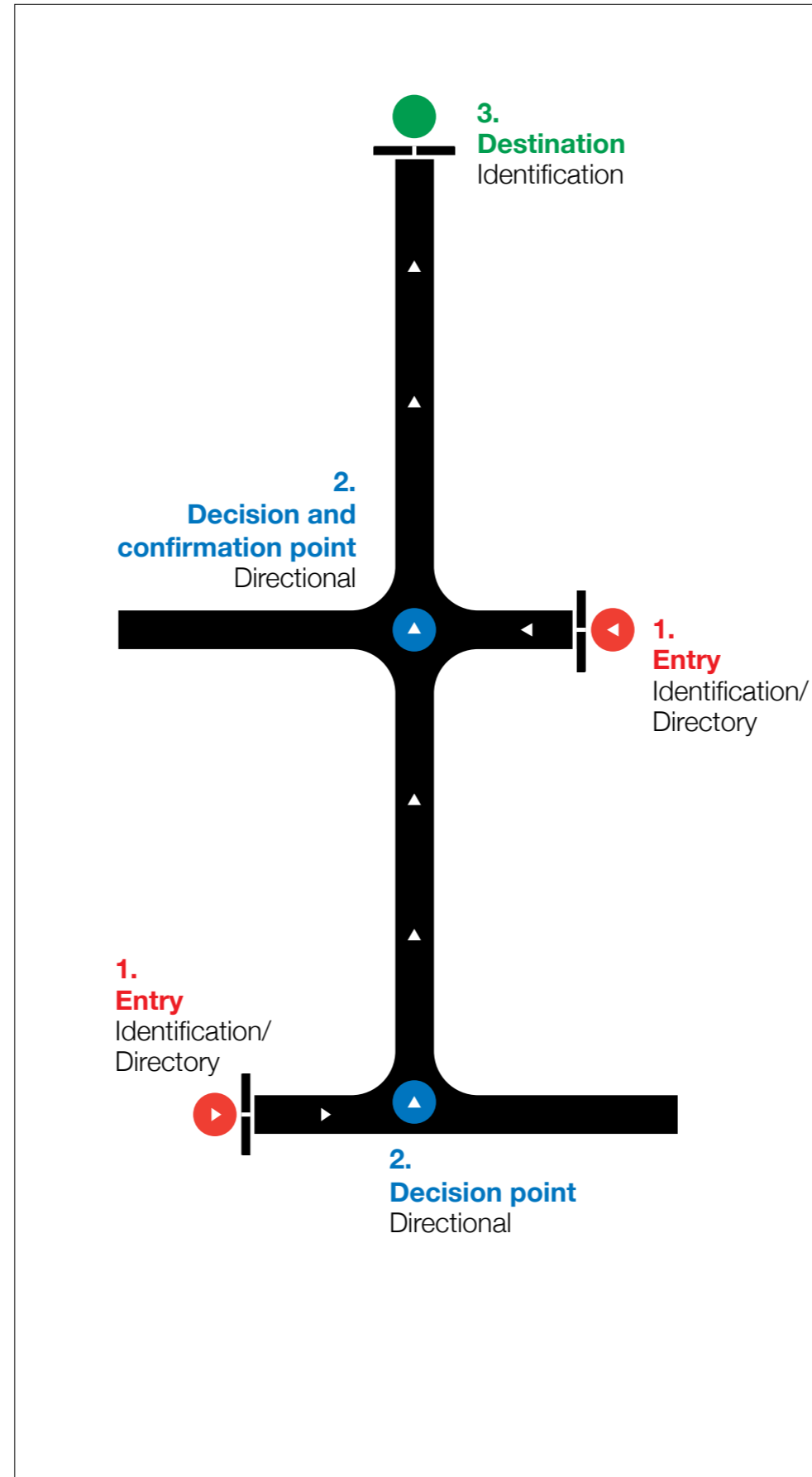

Sign Location Plan

The sign location plan documents the sign location on a plan via the alphanumeric code system illustrated in Section 3.

The plan includes but is not limited to;

- The type of the sign, the specific location of each sign illustrating the orientation, height and distance from primary site/building set-out points.
- The sign content including text, pictograms and arrows and including the requirement for tactile and Braille.
- Where services are required for illumination reference to the requirement should be made adjacent to the alphanumeric code.

The sign location plan is developed from the circulation diagram prepared in Step 1. The plan indicates where information is required. Signs and messages need to respond to circulation patterns to and from a destination. Refer to Section 4 for typical signage locations for key destinations around campus.

Sign Decision Points

Typically information is required at all **pedestrian entry points (1)** to the site, at site boundaries and at building entries and across the site from one building to another.

Internal entry foyers at ground level and on other levels that connect to adjacent buildings require directional information to navigate internally including movement devices – lift, stairs and escalators. These are typically **decision points (2)**.

All rooms and facilities require **destination identification (3)** dependent on the allocation of the destination in the nomenclature hierarchy illustrated in Section 3.

Accessible pathways require signs if they differ from the primary circulation route and accessible facilities must be included on relevant signage.

Step 3: Sign Selection

ID

Identification

Identification signage is used to identify places and destinations, ranging from entrances and gates to room identification. Refer to Section 3: Addressing and Terminology for a comprehensive listing of campus destinations and their identification terminology.

DR

Directional

The directional category includes directories and directional signs. Directory signs list destinations and direct to and from places and destinations in the immediate precinct or level. Directional signs direct to and from places and destinations.

CP

Car Park

Car park signage is concerned primarily with identification, directional, and operational signage in the vicinity of campus car parks, and their specific requirements. It has been separated from the other categories to facilitate material specifications in these locations.

OP

Operational

Operational signs illustrate staff and campus operations and BOH destinations including regulatory messages, prohibitive and safety information. They also include campus facilities such as drop boxes, water refill points, and waste bin signage.

ST

Statutory

Statutory signage covers a wide range of hazard, danger, and security notices, as well as those required by BCA standards for fire safety or laboratory operations.

TD

Temporary & Display

Temporary and display signage refers to signs for the purpose of short-term use or that are appropriated for the display of student or staff-produced signage. This includes noticeboards, display frames, and construction hoarding.

EG

Environmental

Environmental signage refers specifically to privacy graphics and safety decals that serve site-specific functions around campus.

-

Specialty

Specialty signage refers to bespoke signs designed for specific university projects and sites. These are intended to provide a framework for future bespoke designs only.

UNSW Sign Types Family

The UNSW sign family consists of eight functional sign types, that encompass the range of external, internal, statutory, and temporary signage required by the campus. Sign selection is dependent on functional requirements;

- Where is the sign located?
- What information is required at that location?
- Which sign illustrates the information required to deliver legible wayfinding?

Section 9 provides an overview of the sign types, and sections 10 – 17 illustrate sign purpose, location guidelines, graphic standards, finishes and materiality for each sign. An explanation of the eight functional sign types are noted here.

The following pages illustrate the sign selection process for a typical journey within the Electrical Engineering Building.

Refer to Section 4: User Journey for a comprehensive breakdown of internal and external user journeys and sign selections.

Step 3: Sign Selection

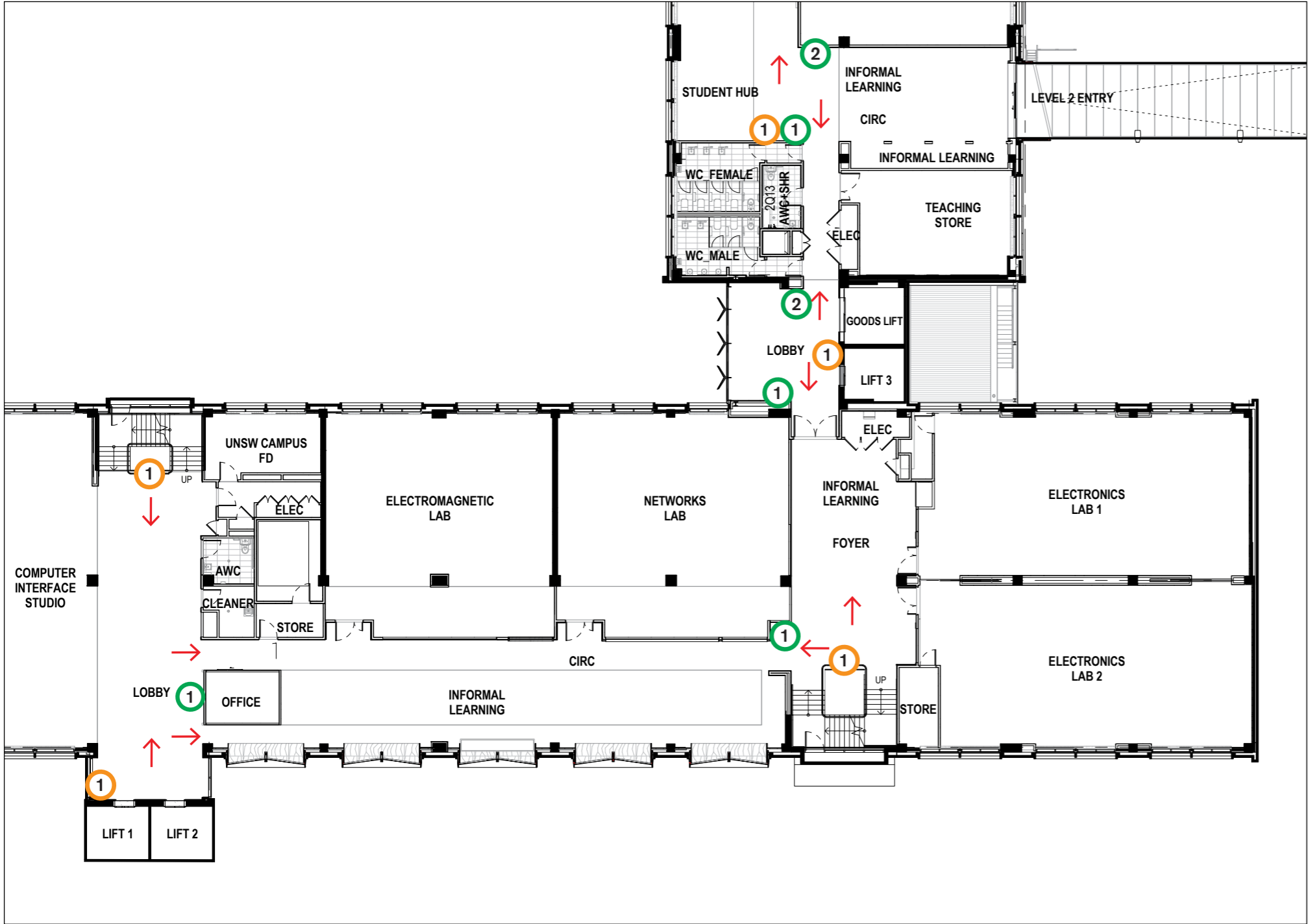



Masterplanning consists of selecting specific sign types and allocating their position to respond to information gathered from step 1 and 2. The master plan should include present and future goals and the probability of long term message changes. Creating a master plan is an economical investment that ensures both accurate and functional decisions are made in the roll out process. The adjacent plan showcases a primary sign type masterplan exercise for:

Directional sign types

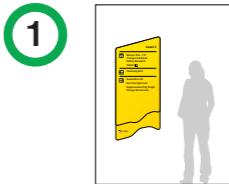
These pages only illustrate a smaller selection of the sign types for this user journey and are only intended as a sample. Refer to Section 4 for a comprehensive breakdown of all proposed sign types.

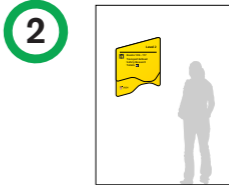
- 

DR.08 Internal Primary Wall-Mounted (Large)
This sign type provides directions to primary and secondary destinations around the site, in a larger format.
- 

DR.09 Internal Primary Wall-Mounted (Small)
This sign type provides directions to immediate destinations around the site, in a smaller format.
- 

ID.15 Internal: Lift Directory (Digital)
This sign type provides a directory listing of destinations within a building, located at a lift lobby, in a digital format. or
- 

ID.16 Internal: Lift Directory (Static)
This sign type provides a directory listing of destinations within a building, located at a lift lobby, in a static format.

Step 3: Sign Selection

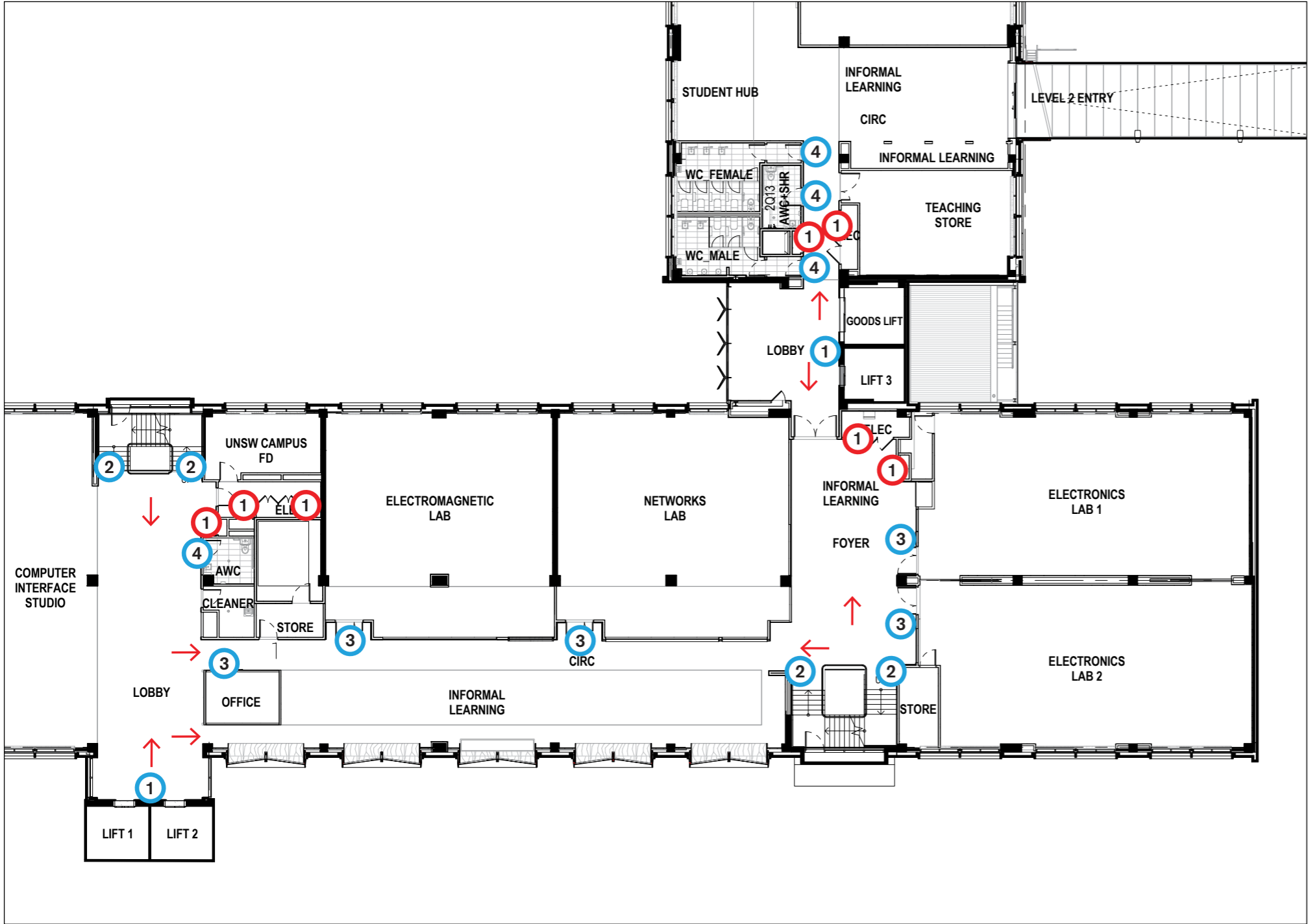

Secondary sign types

These pages only illustrate a smaller selection of the sign types for this user journey and are only intended as a sample. Refer to Section 4 for a comprehensive breakdown of all proposed sign types.

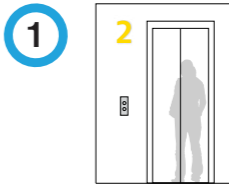
- 

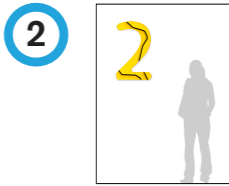
1 **ID.18** Lift Level ID
This sign type informs users of the current building level upon leaving a lift.
- 

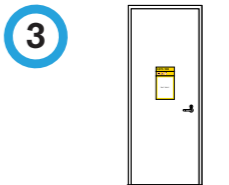
2 **ID.17** Stair Level ID
This sign type informs users of the current level at the entrance to internal stairs.
- 

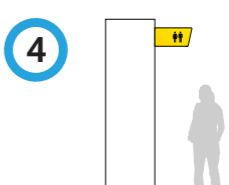
3 **ID.20** Room ID Family
This sign type acts as room identification, and can provide information such as room number, name, timetables or hazard sheets, and accessible facilities.
- 

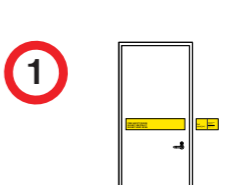
4 **ID.21** Amenity Blade Family
This sign type acts as an identifier for amenity facilities and is located next to the entrances of these facilities.
- 

1 **ST.02** Fire Door Family
This sign type provides statutory information and identifies statutory facilities such as fire doors and their associated warnings.

Step 4: Sign Content

Category	Category Title	Definition	Categorisation Protocol
0	Primary Campus Identification	<ul style="list-style-type: none"> The official master brand mark for University of New South Wales, Sydney. The logo is not to be altered in anyway and no elements are to be used individually (e.g.: do not use the crest or 'UNSW' alone) 	<ul style="list-style-type: none"> Landscape version to be used only. Refer to UNSW brand guidelines
1	Secondary Campus Identification (optional)	<ul style="list-style-type: none"> Campuses under the UNSW umbrella outside of the main Kensington Campus, Sydney 	<ul style="list-style-type: none"> Inclusion of new secondary campus names must be approved by the relevant authority within the University to ensure a consistent approach is adopted across the university
2	Streets & Walkways	<ul style="list-style-type: none"> Major streets classified by Roads & Maritime Services and Councils at the perimeter of the campus site and main walkways within the campus site. 	<ul style="list-style-type: none"> Inclusion of new or alteration of existing street names and walk ways must be approved by the relevant authority within the University to ensure a consistent approach is adopted across the university
3	Level & Vertical Circulation	<ul style="list-style-type: none"> Internal identification system for multi level and subterranean buildings 	<ul style="list-style-type: none"> Level 00 is always represented as 'Ground' Levels 01 and above are represented as 'Level 1', 'Level 2', etc. Levels below Level 00 are classified as basement levels and must be represented as 'Level B1', 'Level B2', etc. This protocol overrides all level numbering provided by architects. It is essential that all buildings adopt the same level number system to ensure a consistent wayfinding experience between faculties.

Naming Terminologies

Sign content categories 0 – 13 nominate the recommended content for each sign type at UNSW. The categorisation of destinations at UNSW into a structured hierarchy ensures a consistency of content in relation to which destinations are identified on the signs and how they are identified. Destinations are categorised according to location types, and also with reference to who are the users of that information. The categorisation forms the basis of the content approach to each sign type, and inform what information is available to users at what point along their journey.

Note:

Refer to Section 3: Addressing and Terminology for a comprehensive listing of all categories and their contents, as well as addressing strategies and hierarchies.

New Destinations

The categorisation of new destinations is at the discretion of UNSW Signage Contractors or Estate Management, and must be approved by the Executive Director or Associate Director, with careful reference to category definitions presented in the table.

Step 4: Sign Content

Category	Category Title	Definition	Categorisation Protocol
5	Primary Campus Destinations	<ul style="list-style-type: none"> Major educational and cultural buildings used by external and internal audiences. This can include: <ul style="list-style-type: none"> - Faculty buildings - Faculty lecture theatres - Entertainment & arts facilities - Mixed use educational areas with minimum 500+ capacity 	<ul style="list-style-type: none"> Inclusion of new primary campus destination names must be approved by the relevant authority within the University to ensure a consistent approach is adopted across the university
6	Secondary Campus Destinations	<ul style="list-style-type: none"> Major shared residential spaces, non-educational facilities & grounds used by external and internal audiences. This can include: <ul style="list-style-type: none"> - Residential buildings - Postgraduate villages - Childcare facilities - Lawns & parks 	<ul style="list-style-type: none"> Inclusion of new secondary campus destination names must be approved by the relevant authority within the University to ensure a consistent approach is adopted across the university
7	FOH Staff Destinations	<ul style="list-style-type: none"> Secondary internal destinations, used primarily by staff. This can include: <ul style="list-style-type: none"> - Faculty offices - Management facilities 	<ul style="list-style-type: none"> Inclusion of new primary campus destination names must be approved by the relevant authority within the University to ensure a consistent approach is adopted across the university
8	Student Services Destinations	<ul style="list-style-type: none"> Tertiary internal destinations, used primarily by students. This can include: <ul style="list-style-type: none"> - Student support services - University run health facilities - Student focused security and management 	<ul style="list-style-type: none"> Inclusion of new student service destination names must be approved by the relevant authority within the University to ensure a consistent approach is adopted across the university

Naming Terminologies

Sign content categories 0 – 13 nominate the recommended content for each sign type at UNSW. The categorisation of destinations at UNSW into a structured hierarchy ensures a consistency of content in relation to which destinations are identified on the signs and how they are identified. Destinations are categorised according to location types, and also with reference to who are the users of that information. The categorisation forms the basis of the content approach to each sign type, and inform what information is available to users at what point along their journey.

Note:

Refer to Section 3: Addressing and Terminology for a comprehensive listing of all categories and their contents, as well as addressing strategies and hierarchies.

New Destinations

The categorisation of new destinations is at the discretion of UNSW Signage Contractors or Estate Management, and must be approved by the Executive Director or Associate Director, with careful reference to category definitions presented in the table.

Step 4: Sign Content

Category	Category Title	Definition	Categorisation Protocol
9	Retail & Hospitality Services	<ul style="list-style-type: none"> External and internal Commerce-use, non-educational related facilities within the UNSW campus site. This can include: <ul style="list-style-type: none"> - UNSW run retail stores - Cafés, Restaurant and Bars - Food courts - Banks - External clinics - Convenient Stores 	<ul style="list-style-type: none"> Inclusion of new retail and hospitality destination names must be approved by the relevant authority within the University to ensure a consistent approach is adopted across the university
10	Student Facing Destinations	<ul style="list-style-type: none"> General use, educational-use facilities. This can include: <ul style="list-style-type: none"> - CATS Rooms - Studios - Workshops - Laboratories 	<ul style="list-style-type: none"> Inclusion of new student facing destination names must be approved by the relevant authority within the University to ensure a consistent approach is adopted across the university
11	Public Services & Amenity	<ul style="list-style-type: none"> Minor shared spaces used by external and internal audiences. This can include: <ul style="list-style-type: none"> - Car parks - Toilets - Change rooms 	<ul style="list-style-type: none"> Inclusion of new public services and amenity destination names must be approved by the relevant authority within the University to ensure a consistent approach is adopted across the university

Naming Terminologies

Sign content categories 0 – 13 nominate the recommended content for each sign type at UNSW. The categorisation of destinations at UNSW into a structured hierarchy ensures a consistency of content in relation to which destinations are identified on the signs and how they are identified. Destinations are categorised according to location types, and also with reference to who are the users of that information. The categorisation forms the basis of the content approach to each sign type, and inform what information is available to users at what point along their journey.

Note:

Refer to Section 3: Addressing and Terminology for a comprehensive listing of all categories and their contents, as well as addressing strategies and hierarchies.

New Destinations

The categorisation of new destinations is at the discretion of UNSW Signage Contractors or Estate Management, and must be approved by the Executive Director or Associate Director, with careful reference to category definitions presented in the table.

Step 4: Sign Content

Category	Category Title	Definition	Categorisation Protocol
12	BOH Staff Destinations	<ul style="list-style-type: none"> • Staff offices/BOH destinations to be identified by name and number. This can include: <ul style="list-style-type: none"> - Staff Offices - Meeting rooms - 'Authorised Access Only' rooms - Control Rooms 	<ul style="list-style-type: none"> • Inclusion of new BOH staff destination names must be approved by the relevant authority within the University to ensure a consistent approach is adopted across the university
13	BOH Building Functions	<ul style="list-style-type: none"> • Statutory identification and operational facilities identified by name/instruction. This can include: <ul style="list-style-type: none"> - Fire Hose Reel - Fire Safety Door - Fire Hydrant Booster 	<ul style="list-style-type: none"> • Inclusion of new BOH building function names must be approved by the relevant authority within the University under the guidance of a certifying authority to ensure Australian standards are consulted prior to application of messaging on site.

Naming Terminologies

Sign content categories 0 – 13 nominate the recommended content for each sign type at UNSW. The categorisation of destinations at UNSW into a structured hierarchy ensures a consistency of content in relation to which destinations are identified on the signs and how they are identified. Destinations are categorised according to location types, and also with reference to who are the users of that information. The categorisation forms the basis of the content approach to each sign type, and inform what information is available to users at what point along their journey.

Note:

Refer to Section 3: Addressing and Terminology for a comprehensive listing of all categories and their contents, as well as addressing strategies and hierarchies.

New Destinations

The categorisation of new destinations is at the discretion of UNSW Signage Contractors or Estate Management, and must be approved by the Executive Director or Associate Director, with careful reference to category definitions presented in the table.

Step 4: Sign Content

Review the masterplan and identify what messages are required based on signs/panels at defined circulation routes and destinations.

Electrical Engineering Building
Signage Schedule
Level 01

SIGNTYPE	SIGN NAME	Construction Level	MESSAGING SIDE A	MESSAGING SIDE B	NOTES	QUANTITY
DR.07	Primary Wall Mounted Directional: Internal Small	1	Level 1 [up arrow] Transport & Road Safety (TARS) Research Semiconductor Nanofabrication Facility Science Learning & Teaching Unit [UNSW Logo]		200mm to right of door frame	1
DR.07	Primary Wall Mounted Directional: Internal Small	1	Level 1 [right arrow] Super Conducting Single Charge Device (SC2) Lab Electron Spin Resonance Lab Toilets [Unisex and Accessible Pictogram] [UNSW Logo]		NA	1
DR.08	Primary Wall Mounted Directional: Internal Large	1	Level 1 [up arrow] Transport & Road Safety (TARS) Research Semiconductor Nanofabrication Facility Science Learning & Teaching Unit Physics First Year Teaching Lab L1 Rooms 109 - 117 W206, 234 Offices [right arrow] Super Conducting Single Charge Device (SC2) Lab Electron Spin Resonance Lab Acoustics Lab Toilets [Unisex and Accessible Pictogram] [UNSW Logo]		200mm to left of door frame	1
DR.08	Primary Wall Mounted Directional: Internal Large	1	Level 1 [right arrow] Science Learning & Teaching Unit Physics First Year Teaching Lab L1 Rooms 109 - 117 W206, 234 Offices [left arrow] Super Conducting Single Charge Device (SC2) Lab Electron Spin Resonance Lab Acoustics Lab Toilets [Unisex and Accessible Pictogram] [UNSW Logo]		NA	1
DR.08	Primary Wall Mounted Directional: Internal Large	1	Level 1 [up left arrow] Transport & Road Safety (TARS) Research Semiconductor Nanofabrication Facility Physics First Year Teaching Lab L1 Rooms 109 - 117 [right arrow] Super Conducting Single Charge Device (SC2) Lab Electron Spin Resonance Lab Toilets [Unisex and Accessible Pictogram] [UNSW Logo]		NA	1
ID.18	Internal ID: Lift Level ID	1	1		Fix centred above lift call button	4
ID.20	Room ID	1	Room 20		NA	1
ID.20	Room ID	1	Room 21		NA	1
ID.20	Room ID	1	Room 22		NA	1
ID.20	Room ID	1	Room 23		NA	1
ID.20	Room ID	1	Room 24		NA	1
ID.20	Room ID	1	Room 25		NA	1
ID.20	Room ID	1	Room 26		NA	1
ID.21	Amenity ID: Blade	1	[Male Pictogram]	[Male Pictogram]	NA	3
ID.21	Amenity ID: Blade	1	[Female Pictogram]	[Female Pictogram]	NA	3
ID.21	Amenity ID: Blade	1	[Unisex Pictogram] [Accessible Pictogram]	[Unisex Pictogram] [Accessible Pictogram]	Align to adjacent door frame	1
ST.02	Statutory: General Fire Door	1	FIRE SAFETY DOOR DO NOT OBSTRUCT DO NOT KEEP OPEN		NA	11
ST.02	Statutory: General Fire Door	1	FIRE SAFETY DOOR DO NOT OBSTRUCT		NA	4
ST.03	Statutory: Fire Extinguisher & FHR	1	FIRE HOSE REEL		NA	4
ST.03	Statutory: Fire Extinguisher & FHR	1	FIRE EXTINGUISHER		NA	2
ST.03	Statutory: Fire Extinguisher & FHR	1	FIRE HOSE REEL FIRE EXTINGUISHER		NA	4

Signage Content Schedules

Sign message content is documented in a Signage Content Schedule. The schedule is linked to the sign location plan via the alphanumeric code system for the signs illustrated in Section 3. Graphic layouts for the signs illustrates the type of content each sign has been designed to contain.

Steps 5 – 8: Procurement and Artwork

Step 5:

Procurement

Facilities Information Manager, FMO and the UNSW Project Manager determines procurement process suitable for the scale and type of sign program which may include the removal of existing signage and make good, removal and replacement of existing signage or a new sign program.

Procurement for major projects may include all or part of the following items;

Tender response

1. Material samples (see below)
2. List of tests included or warranties supplied
3. QA/ QC programme, including Work Method Statement and Risk Management plan
4. List of proposed Shop Drawings and prototypes
5. Summary of deviations from the Sign Manual
6. Outline technical specifications reflecting proposed materials/ systems, etc.
7. A list of proposed suppliers and subcontractors intended to be used

Material samples

1. 300mm x 300mm sign of each type in specified colour
2. Font and lettering/ numbering sample
3. Fixing and seals
4. All visible light fittings of each type
5. All metal/ acrylic finishes that signage is applied to
6. All digital output test strips and examples of substrate, finish, output resolution including anti-graffiti coatings as required
7. All self-adhesive films

Prototypes

Prototypes for whole or part sign items as requested by client.

Step 6:

Site Inspection

The Signage Contractor is to conduct a site inspection to establish accurate dimensions and locations of signs. Highlight any location amendments required due to tolerances and differences between the site and the Sign Manual location guidelines. For current buildings, including but not limited to; coordination with existing fixtures and fittings, including signs is required, existing services and structures.

For new buildings, including but not limited to; coordination with fixtures and fittings, services and structures is required.

Step 7:

Creation of Artwork

Artwork for the sign items either whole or part are to be created by the Signage Consultant and/or the Signage Contractor depending on procurement procedure. Artwork to be prepared as noted below.

Any computer generated artwork required is to be supplied as an electronic vector file (.pdf or .ai). Each typical signage messaging template is required to be submitted for review/approval.

The Signage Contractor is to allow for the input of content, enlargement as required of the material, preparation of full-sized or to scale graphic layouts for approval, production of stencils and silk screens, printing on to sign panels and background material, cutting out and fabrication of metal letters all as specified and set out in the Sign Manual.

The Signage Contractor must provide 1:1 or to scale printouts of one of each sign type and electronic files of all artwork for all messages, for approval of kerning and fonts by UNSW.

The Signage Contractor must prepare layout and artwork for the tactile and Braille sign panels. The Signage Standards illustrate indicative set outs for standard text on these panels and indicate the area, size and zone for the tactile and Braille component. The Signage Contractor must prepare final layouts with supplied message content for review/approval and ensure compliance with relevant BCA and AS standards.

Step 8:

Approval of artwork

The Signage Contractor shall provide to UNSW final finished artwork proofs at an appropriate scale for all signs prior to manufacture. Each finished artwork proof will be required to have signed approval by the Signage Contractor prior to submission to UNSW and be counter-signed 'APPROVED' by UNSW prior to manufacture.

Steps 9 – 15: Fabrication and Installation

Step 9:

Creation of Shop drawings

The Signage Contractor is responsible for developing all sign items for fabrication and installation. For small to medium projects UNSW will determine requirements to produce shop drawings, dependent on sign type allocation and sign type location.

Shop drawings are required for all major procurement projects.

Fully dimensioned and notated shop drawings are required for all signs in the sign program.

Submit shop drawings showing the following information where relevant:

Show plans, elevations and detailed sections. Indicate materials, thickness, finishes, types of joinery, fasteners, anchorage, sleeves and bolts:

1. Layout, construction and fixing details for custom designed (non standard) sign systems.
2. Large scale (full-sized if practicable) lettering layouts for individual letter signs. Shop drawings are to show all instances of messaging layouts (using approved artwork layouts from Step 8) for approval.
3. Full-sized spacing templates for individually mounted characters.
4. Location template drawings for anchorages to permanent construction
Show type of anchorage.
5. Wiring diagrams for illuminated signs.
6. Supply proofs for all digital images

Provide a digital copy of the shop drawings in a format accepted by UNSW for future signs.

Step 10:

Approval of Shop drawings

UNSW/Signage Consultant is to review/mark up for amendment and sign 'APPROVED' when UNSW/Signage Consultant are satisfied with the shop drawings. 'APPROVED' drawings indicates the sign fabrication can commence for that sign item.

Step 11:

Fabrication

The Signage Contractor following receiving the 'APPROVED' shop drawings can commence fabrication of the signage in accordance with the Sign Manual and 'APPROVED' artwork and shop drawings.

Step 12:

Installation

Sign installation on site according to the Sign Manual and 'APPROVED' artwork, shop drawings and procurement requirements.

Step 13:

Defects Review

UNSW/Signage Consultant to review the sign installation and prepare a defect list. Utilising digital images and notes list all items that require amendment.

Step 14:

Rectification

The Signage Contractor to rectify the defects as noted and as in accordance with the procurement requirements.

Step 15:

Final Approval

UNSW to approve either/or the commencement of the defects liability period or final completion of the sign program.

Section

6.0

Conceptual Overview

This section outlines the conceptual pillars that underpin the creative for the wayfinding design.

2025 Masterplan Drivers

Concept Pillars

Concept – Limitless Landscape

2025 Masterplan Drivers

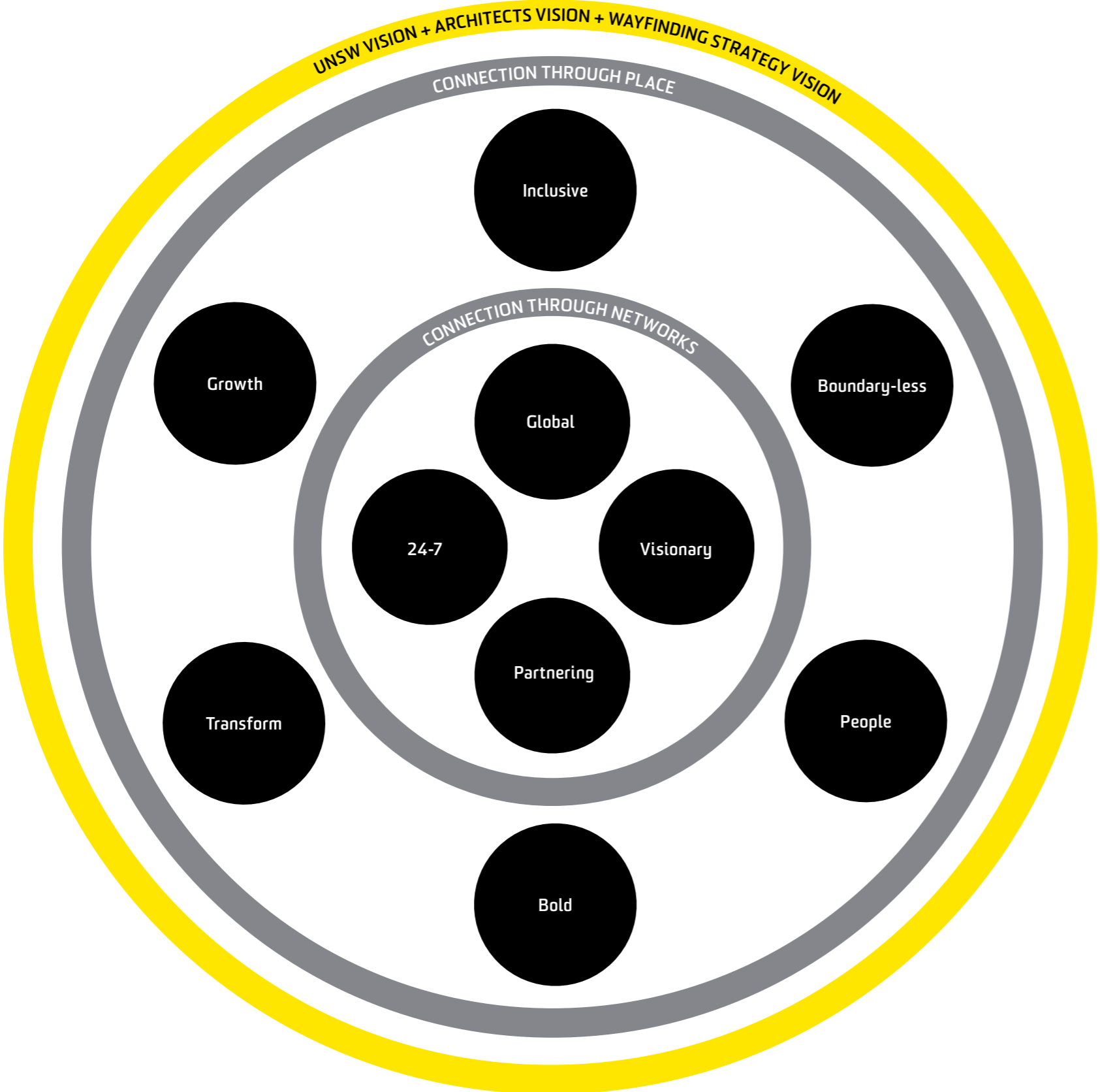

The principles that drive the '2025 Masterplan Framework', produced by Hassell, have informed all wayfinding and placemaking, ensuring that all signage, architecture and the UNSW identity are presented in a single cohesive expression.

Concept Pillars

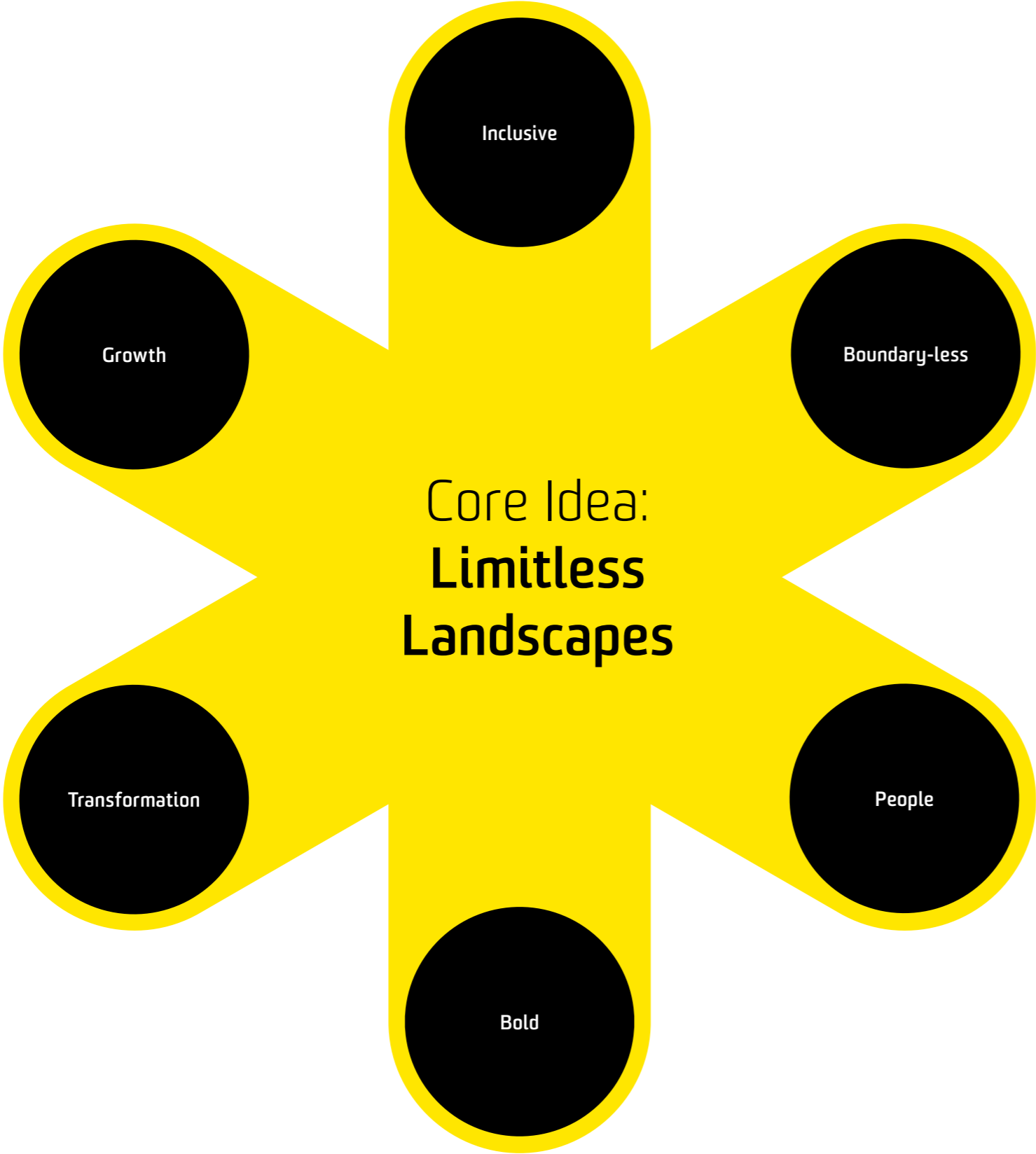

The conceptual pillars shown are taken directly from the 'UNSW Design Masterplan Framework' by Hassell. To ensure the wayfinding system is cohesive with the UNSW site and identity, the conceptual foundation which informs the signform designs and their underlying systems are derived from the 2025 Masterplan pillars. By adopting the same vision and principles, the wayfinding system is reflective of the surrounding architecture and overall spirit of UNSW.

Concept – Limitless Landscape



UNSW has an ever-changing topography that enables communication, collaboration, and celebration of academic achievement and innovation. Through the acknowledgment of our ancient landscape, our ability to connect in all forms is limitless.

The design concept looks to the idea of layering and organic formation over time. The staccato formations speak to investigation, uncovering information and the quest for deeper understanding. The line work and repetitive steps speak to the unique UNSW coastal location and the land, the regions topography and the tides.

Reference Images



Initial concept explorations

Concept – Limitless Landscape

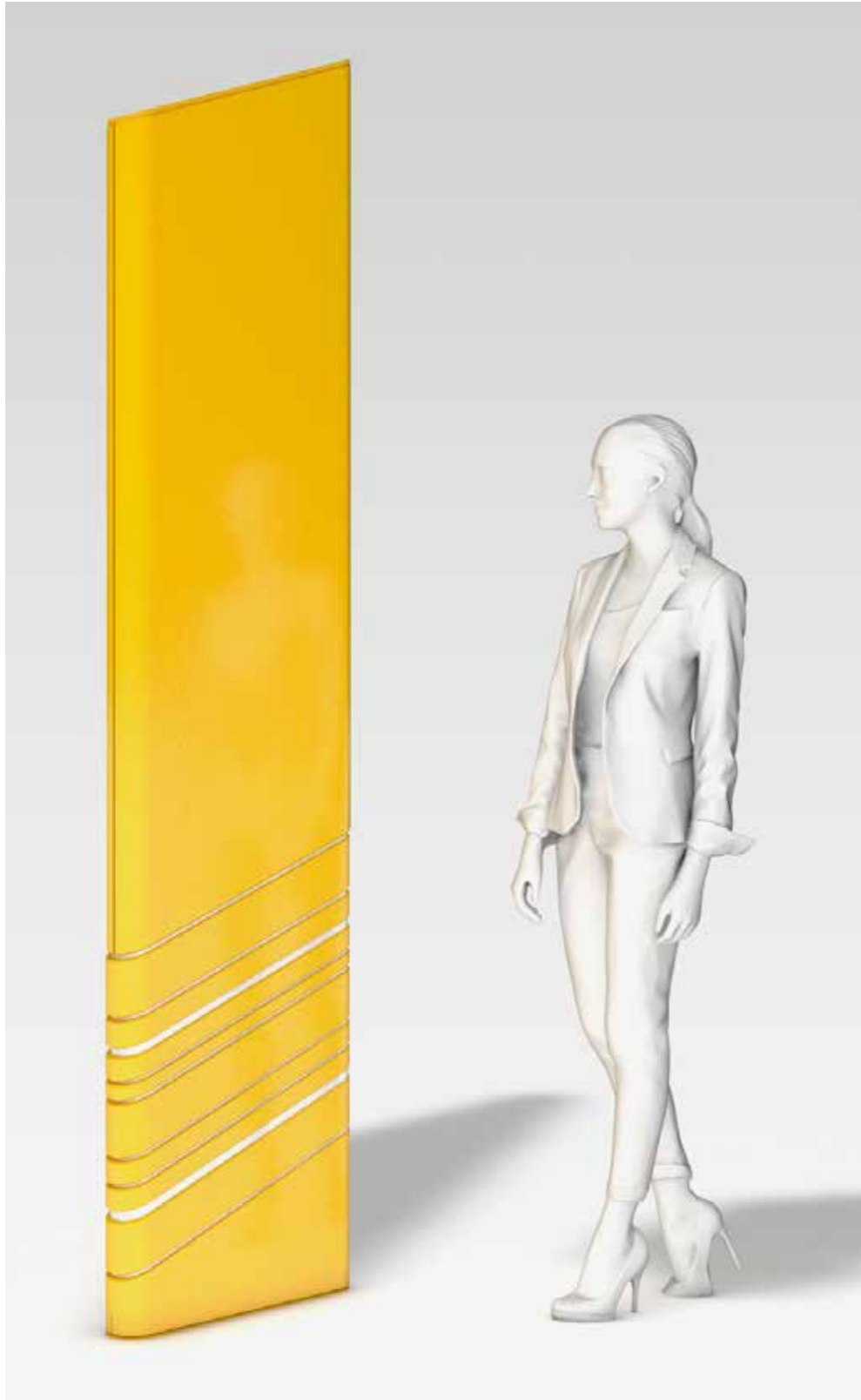

Final primary totem form
Scale N/A

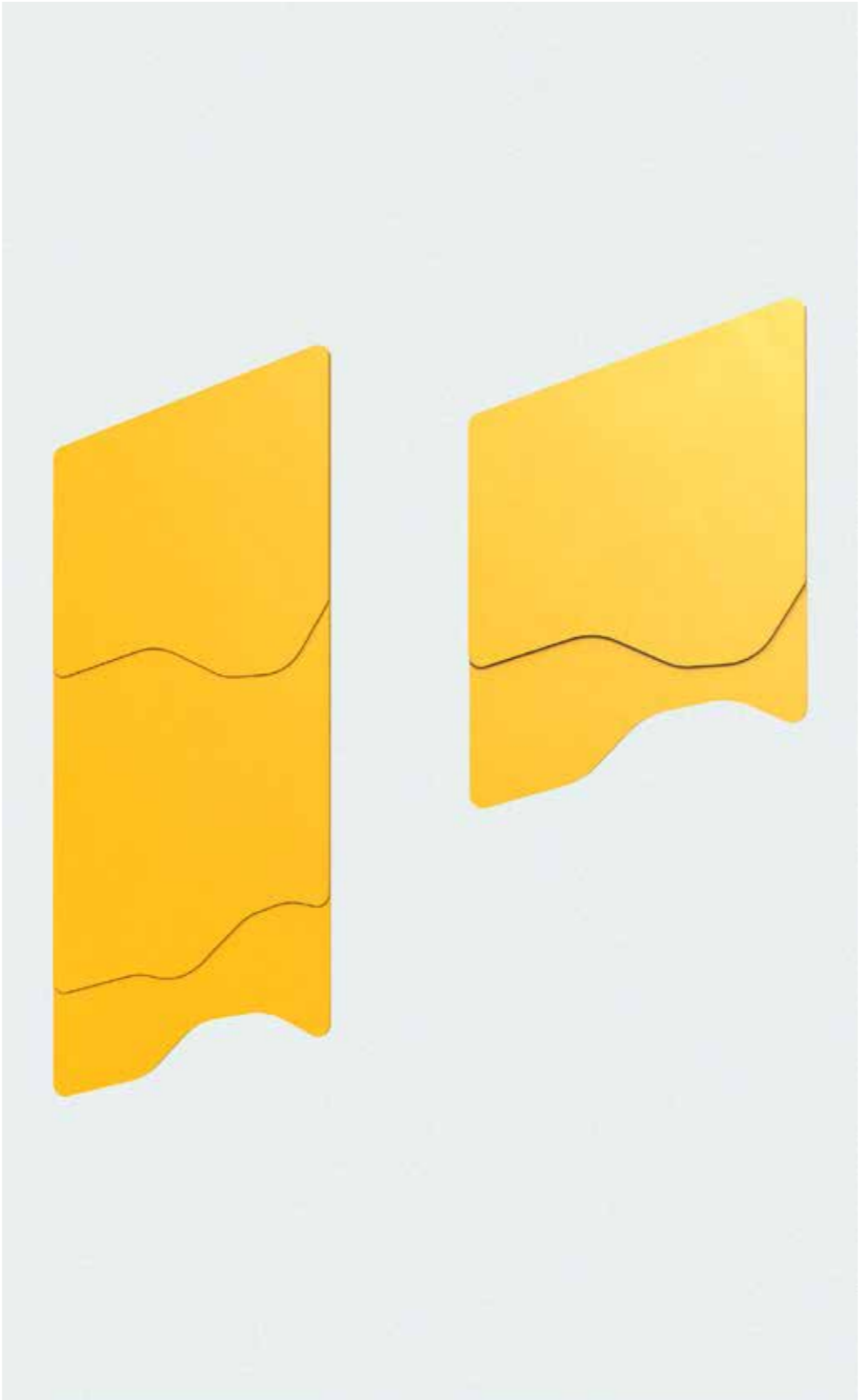

Final wall mounted sign form
Scale N/A

The narrative of rock formations is materialised through the two main signforms of the signage system, the freestanding totem and the primary wall mounted sign.

The visual language of layering and undulating lines distinct to rock formations are expressed through the organic form, slanted angles and illumination of the base for the totem and the bottom profiles on wall mounted signage panels.

Concept – Limitless Landscape



ID.07 Wall Mounted Sign Type

Scale N/A



UNSW Coastline

South Coogee coastline Maroubra beach to Thompsons Bay
Scale N/A

The ends of each panel that form the primary sign forms of the wall mounted family are derived from the UNSW coastline, encapsulating the university identity in a unique manner that complements the 2025 architectural conceptual plan.

Concept – Limitless Landscape



Final primary totem design
Scale N/A



Final wall mounted design
Scale N/A

Combined with graphics designed for wayfinding, the visual and dimensional layering enables clever use of illumination and spaces for hierarchical messaging, heightening the conceptual characteristics as both sculptural yet functional elements of the signage design.

Section

7.0

Graphic Standards

This section outlines the graphic standards that apply to the wayfinding design.

Logo Overview

Signage Colour Palette

Typography

Arrows

Pictogram Suite

Messaging Hierarchy

Messaging Layouts

Logo Overview

Small Logo

50mm height
Scale 1:5

- All pedestrian signage that requires a logo. Excluding gate sign types.



Large Logo

240mm height
Scale 1:5

- For gate entry totems, both pedestrian and secondary vehicular



UNSW
SYDNEY

Main Gate Logo

290mm height
Scale 1:5

- For primary gate totem only



UNSW
SYDNEY

The UNSW Crest Logo incorporates the UNSW Emblem and the university title. It is the preferred approach when referring to the university. It is essential that the UNSW brand is represented accurately and consistently in all communications to reflect the positioning and values of the university. The logo must be used as instructed in the manual.

Certain signs may have differing logo sizes specific to their layout and proportions. Refer to individual sign types for details.

Signage Colour Palette

Main Colour Palette

(All wayfinding sign forms)

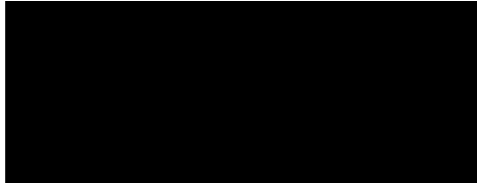

UNSW Yellow – C0 M5 Y100 K0

Specific to all primary, secondary and statutory signforms.

Paint: Dulux Dandelion Yellow A205
Self-adhesive film: Avery Primrose Yellow #707
Print: PMS 108C Yellow

Black – C0 M0 Y0 K100

Specific to all primary, secondary and statutory signforms.

Paint: Dulux Black SG6G9
Self-adhesive film: Avery Matte Black 180
Print: C0 M0 Y0 K100

White – C100 M100 Y100 K0

Specific to all primary sign forms.

Paint: Dulux Vivid White SW1G1
Self-adhesive film: Avery Matte White 102
Print: C100 M100 Y100 K0

Colours have been chosen to achieve a high level of contrast and legibility as well as create a distinct signage system recognisable through colour. Colours relevant to statutory signage must comply with all Australian Standards and BCA requirements.

Statutory Colour Palette

(Statutory sign forms only where required)



Accessible Blue

Paint: B21, Ultramarine as per AS2700
Self-adhesive film: to match PMS 2945
Print: to match PMS 2945

Traffic Green

Paint: G21, Jade as per AS2700
Self-adhesive film: to match PMS 348 U
Print: to match PMS 348 U

Signal Red

Paint: R13, Signal red as per AS2700
Self-adhesive film: to match PMS 1795 U
Print: to match PMS 1795 U

Traffic Yellow

Paint: Y15, Sunflower Yellow as per AS2700
Self-adhesive film: to match PMS 115 U
Print: to match PMS 115 U

Typography

FS Millbank Regular – For all typical messaging

ABCDEFGHIJKLMNOPQRSTUVWXYZ
abcdefghijklmnopqrstuvwxyz
0123456789,,:;"'(&!\$%@)!?

FS Millbank Bold – For building identification or level headers

ABCDEFGHIJKLMNOPQRSTUVWXYZ
abcdefghijklmnopqrstuvwxyz
0123456789,,:;"'(&!\$%@)!?

FS Millbank Regular – Arrow Suite

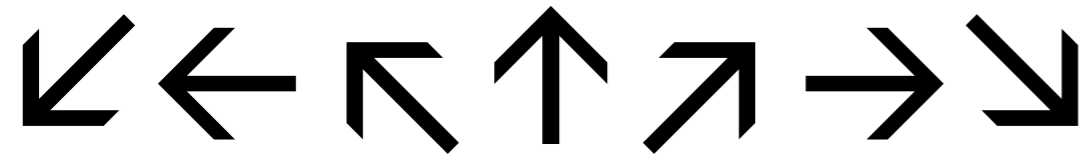

The UNSW wayfinding font is **FS Millbank**. Copy can be set in regular or bold weight depending on the sign type.

Arrows must utilise the **FS Millbank** font family, in regular weight. No other arrow styles are to be used unless specified.

Typography

Tracking

Buildings 10, 11

For optimum legibility, use the correct tracking, kerning, word spacing and leading on all signs.

Tracking

+ 10, optical kerning

Kerning

Some combinations of letters should be kerned visually to ensure legibility and visual consistency, as shown in examples to the left.

Leading

For signage typesetting, the minimum leading equals the lower-case 'x height' of the word as shown in the leading diagram.

Kerning

10, 11

Poorly kerned
Space between numbers is too open

10, 11

Correctly kerned
Space between numbers is visually consistent





Leading

Please leave bicycles
in racks provided

x height

Arrows

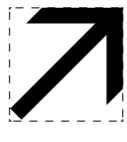
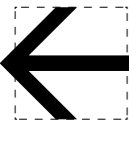
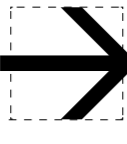
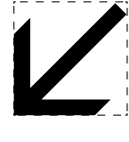
Standard Arrows

- 1.  Ahead
- 2.  Diagonally up left
- 3.  Diagonally up right
- 4.  Left
- 5.  Right
- 6.  Diagonally down left
- 7.  Diagonally down right
- 7.  Do not use

Arrow Usage & Hierarchy

- 1.  Destination 1
- 2.  Destination 2
- 3.  Destination 3
- 4.  Destination 4
- 5.  Destination 5

Standard Arrows

Arrows play a major role in wayfinding. To fulfil their purpose in the most effective manner, arrows must be used consistently. The arrow is part of the **FS Millbank** font family. To be set in **FS Millbank Regular**.

Arrow bounding box

A square bounding box has been included in these arrow drawings as guides for the correct alignment of arrows and text. Note that the tip of horizontal and vertical arrows extends beyond the box boundaries. After setting arrows and text, when it is no longer required, the bounding box must be removed from the graphic layout.

Arrow Usage & Hierarchy

A single arrow is required for each direction. Destinations to stack per single directional arrow. When a sign has multiple directional arrows, arrows are to be ordered in a descending manner starting from 1. Diagonal arrows may never be used to direct diagonally backwards. Down pointing arrow should never be used.

Arrow Size

Arrow bounding box must be minimum 0.5 times the cap height of text.

Arrow Alignment

Arrow bounding box must align to margin as shown. Tails and heads of left and right arrows are to sit outside the margin.

Arrow Size

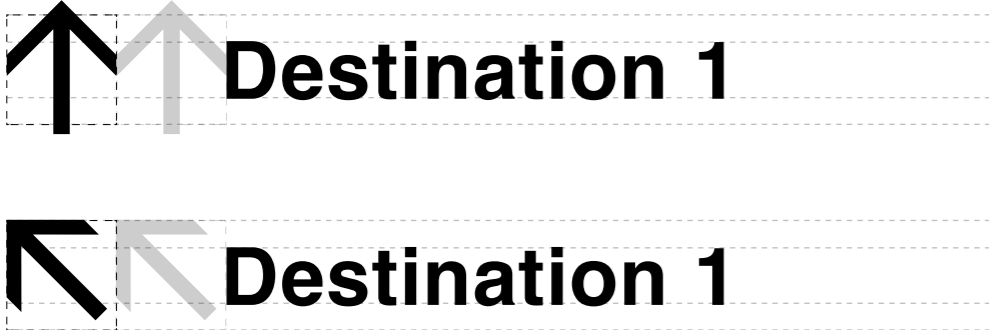

Arrow Alignment



Arrows

Vertical Format 600 Wide



Arrow placement

This page illustrates how arrows are to be laid out on panel in both the vertical and horizontal format.

Vertical Format 600 Wide

Arrows always left justified on panels. Margins defined by arrow size.

Horizontal Format 1200 wide format

Arrows always justified to outside edge of panel. Margins defined by arrow size.

Horizontal Format 1200mm Wide

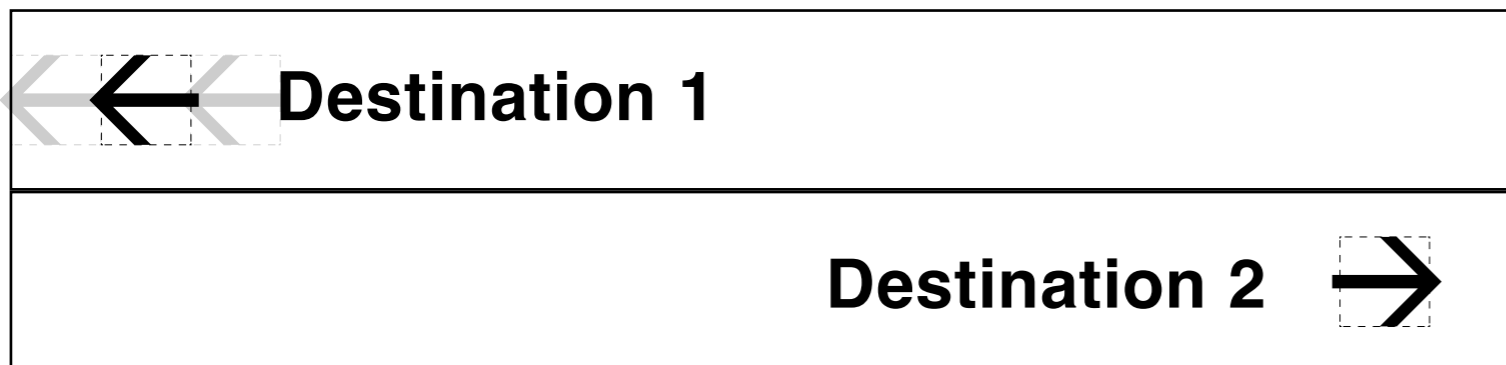

Pictogram Suite

Statutory & Regulatory



Accessibility



Male Toilet



Female Toilet



Unisex Toilet



Male & Female
Separate Toilet



Male
Ambulant Toilet



Female
Ambulant Toilet



Baby Change



Parents Room



Showers



Waste



Mixed Recycling



Organics

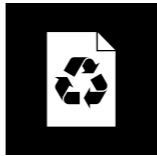

Paper Recycling



Defibrillator



Medical Centre



Hearing Loop



Help Point



International Accessible
(for Statutory only)



Accessible Ramp



All Genders Toilet



Dogs Leashed



CCTV Cameras



No Food or Drinks



No Pets Allowed



No Bikes



No Pedestrian Access



No Smoking











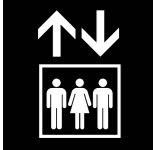
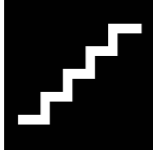





Pictograms apply to the commonly used facilities and services. The pictograms illustrated on these pages are for use on all identification, directional, operational and mapping signs at UNSW.

All pictograms should adhere to international standards as defined in ISO 7001: Public Information Symbols. The label shown beside each pictogram is used for identification and documentation (sign message schedule) purposes. It should not be used together with the pictogram unless a statutory requirement.

The International Accessible pictogram is to be used for DDA compliant amenity signage only. All other instances should use the standard Accessibility symbol or Accessible ramp symbol.

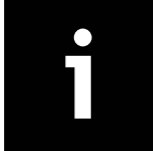
Pictogram Suite

Transport & Utilities

						
Lifts	Stairs	Escalator	Bike	Bus	Shuttle Bus	Loading Zone
						
Drop Off	Parking	Pram Parking	No Entry	Light Rail	Fire Extinguisher	
						
Cafe	Student Services	Post Office	Security Office	Bookshop	Bank	

Pictograms apply to the commonly used facilities and services. The pictograms illustrated on these pages are for use on all identification, directional, operational and mapping signs at UNSW.

All pictograms should adhere to international standards as defined in ISO 7001: Public Information Symbols. The label shown beside each pictogram is used for identification and documentation (sign message schedule) purposes. It should not be used together with the pictogram unless a statutory requirement.

Pictogram Suite

Diagram 1

Typical pictograms used as part of directional signage

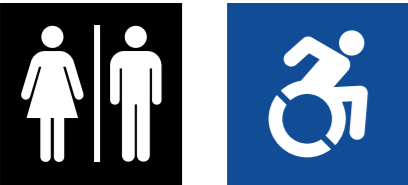

Diagram 2

Typical pictograms used as part of directional signage

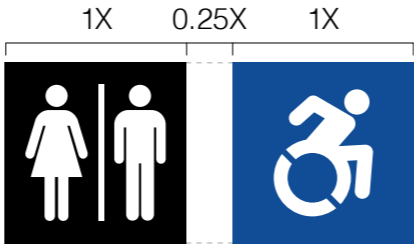

Diagram 1

As shown in Diagram 1, only pictograms from the approved master pictogram family are to be used

Diagram 2

Pictograms are to be scaled and aligned as shown in Diagram 2.

Diagram 3

Pictograms are 1.5 times the height of a capital letter, as shown in Diagram 3. In some cases, pictograms should be scaled proportionately.

The minimum space between directional arrows and text is equal to the arrow width, as shown in Diagram 3. The minimum space between text and pictograms is equal to half width of the arrow, as shown in Diagram 3.

When multiple pictograms are used in a single line, the minimum space between pictograms should be 0.25 the width of a pictogram, as shown in Diagram 2.

Diagram 3



Message Hierarchy



Identification
Building code

Identification
Building name

Regulatory
Messaging and pictograms

UNSW logo

Identification signage



Directional 1
Arrow up

Directional 2
Arrow left

Directional 3
Arrow right

Directional 4
Campus map & legend

UNSW logo

Directional signage

Identification signs

On identification signs, destinations are always displayed with their corresponding map code. Map codes are placed at the top of the hierarchy as they reflect a permanent location within a map grid system. As a result, map codes will always stay the same regardless of building name changes.

Directional signs

On directional signs, directional arrows take first priority when categorising destination lists. Refer to 'Section 2: Graphic Standards, Arrows' for direction order. Destinations are then categorised within the directional cluster using the Terminology Category Lists.

Campus maps should always be placed below directional messaging, with their associated legends.

Messaging Layout – Building Identification

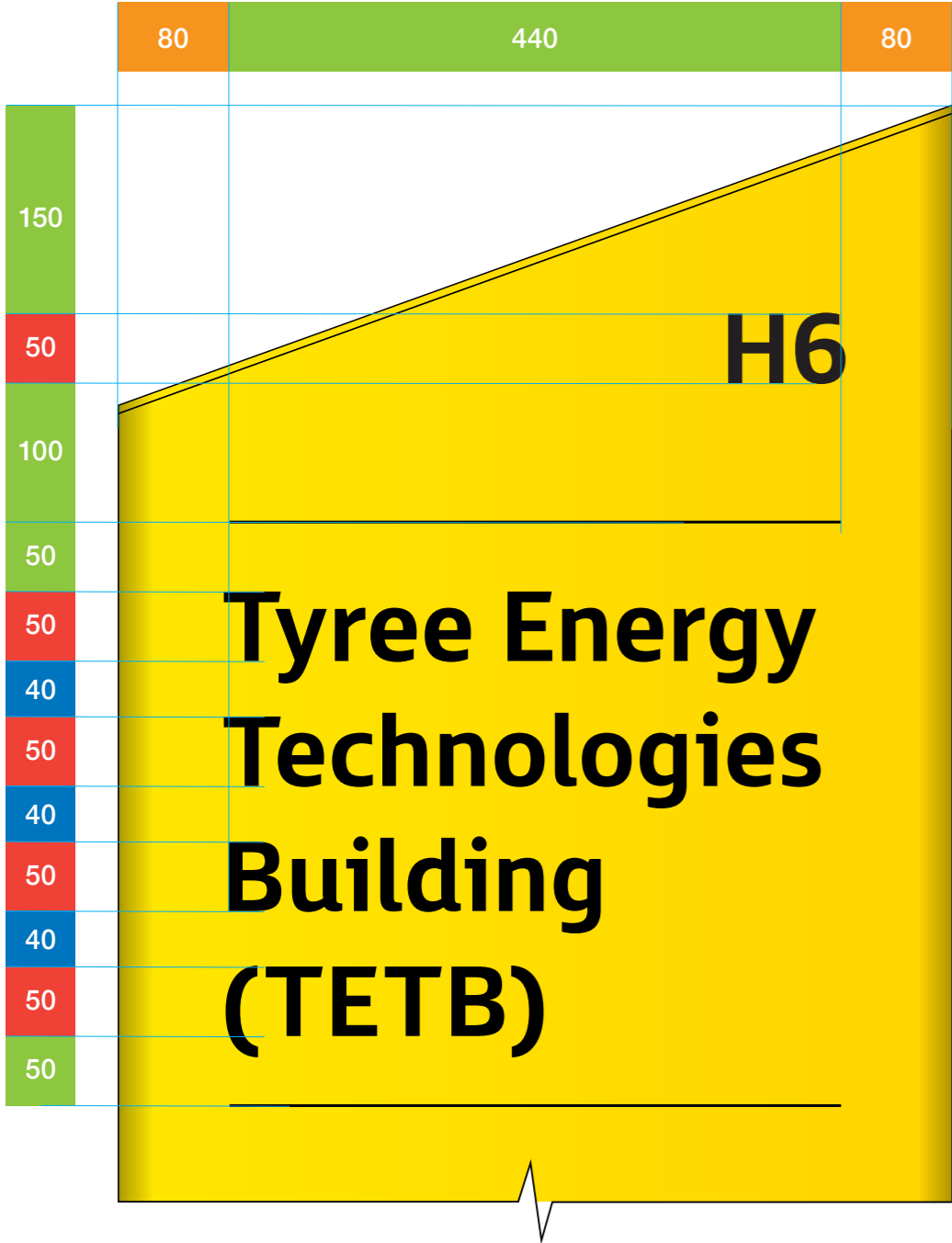

ID.06 External Building ID – Totem

- Cap Height: 50mm
- Leading: 40mm
- Margins: 80mm
- Padding: 150, 100, 50mm

Scale 1:5

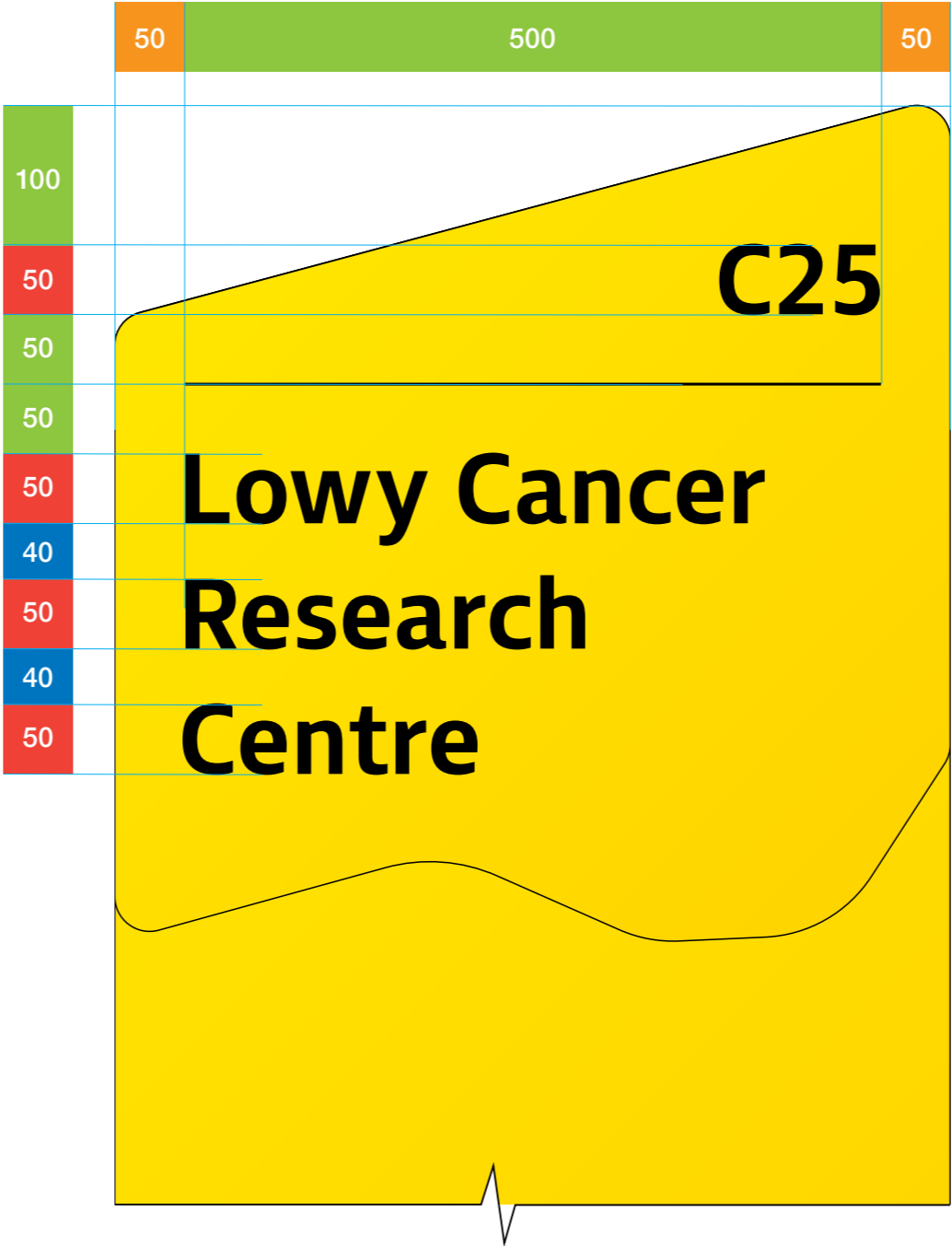

ID.07 External Building ID – Wall

- Cap Height: 50, 40mm
- Leading: 40mm
- Margins: 50mm
- Padding: 100, 50mm

Scale 1:5

Note

Messaging layouts should be applied as the standard across all signage where relevant. Where text size is required to be smaller e.g. to accommodate longer names, any scaling must be done proportionally, and across all elements (text, arrows and pictograms).

Messaging Layout – External Directional

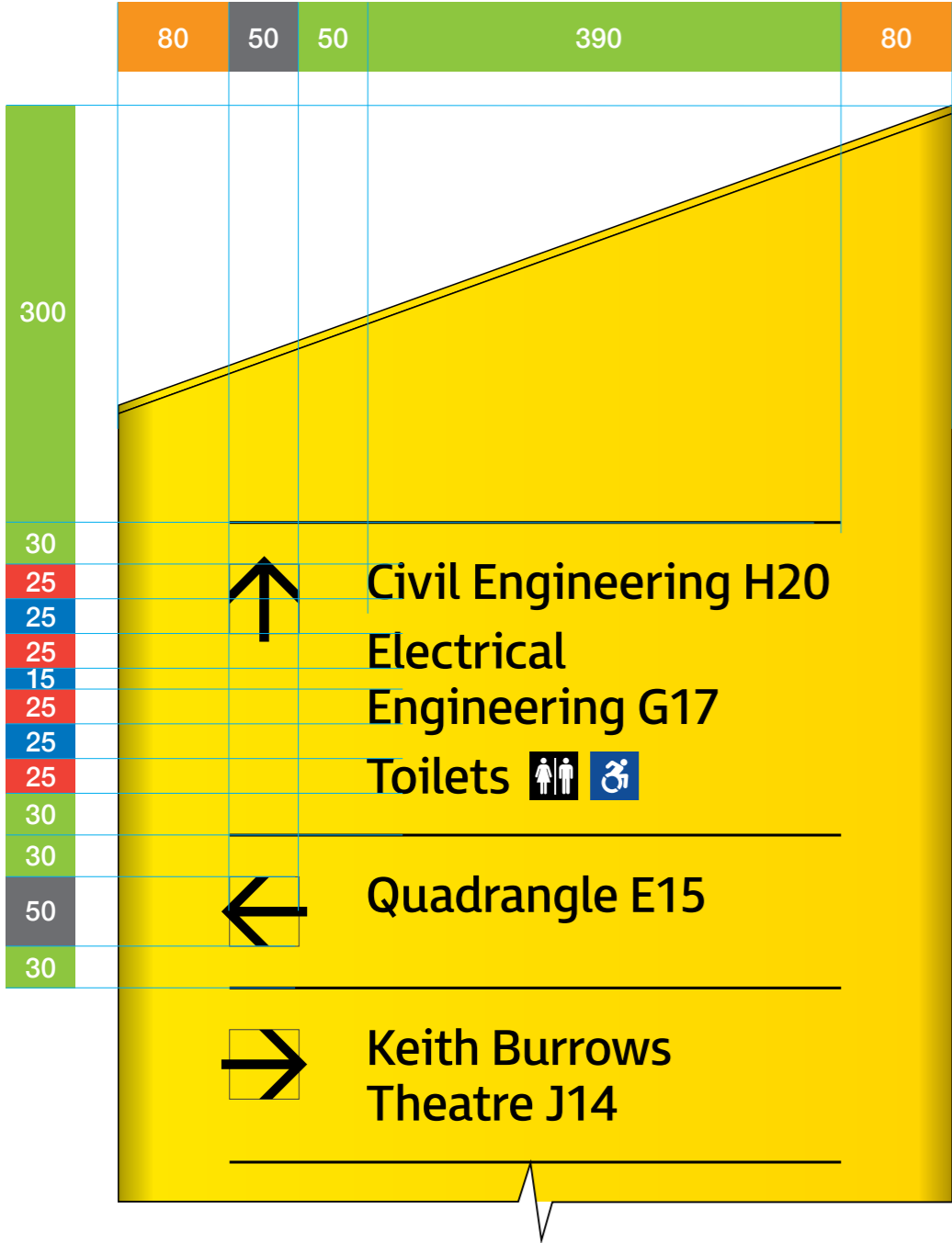

DR.02 / DR.03 External Directional – Totem

- Cap Height: 25mm
- Leading: 25, 15mm
- Margins: 80mm
- Padding: 50, 30mm
- Arrow Height: 50mm

Scale 1:5

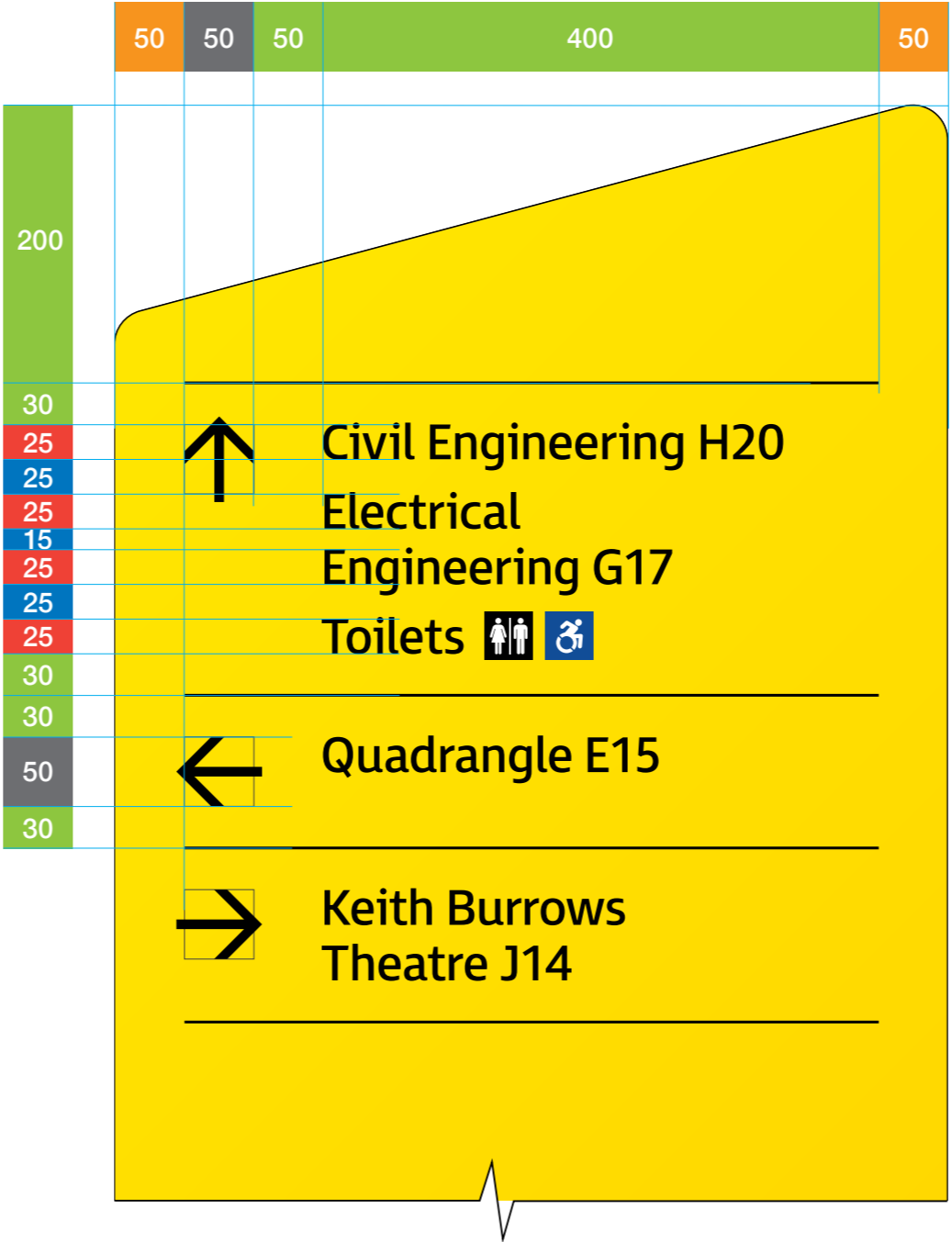

DR.06 / DR.07 External Directional – Wall

- Cap Height: 25mm
- Leading: 25, 15mm
- Margins: 50mm
- Padding: 50, 30mm
- Arrow Height: 50mm

Scale 1:5

Note

Messaging layouts should be applied as the standard across all signage where relevant. Where text size is required to be smaller e.g. to accommodate longer names, any scaling must be done proportionally, and across all elements (text, arrows and pictograms).

Messaging Layout – Internal Directional

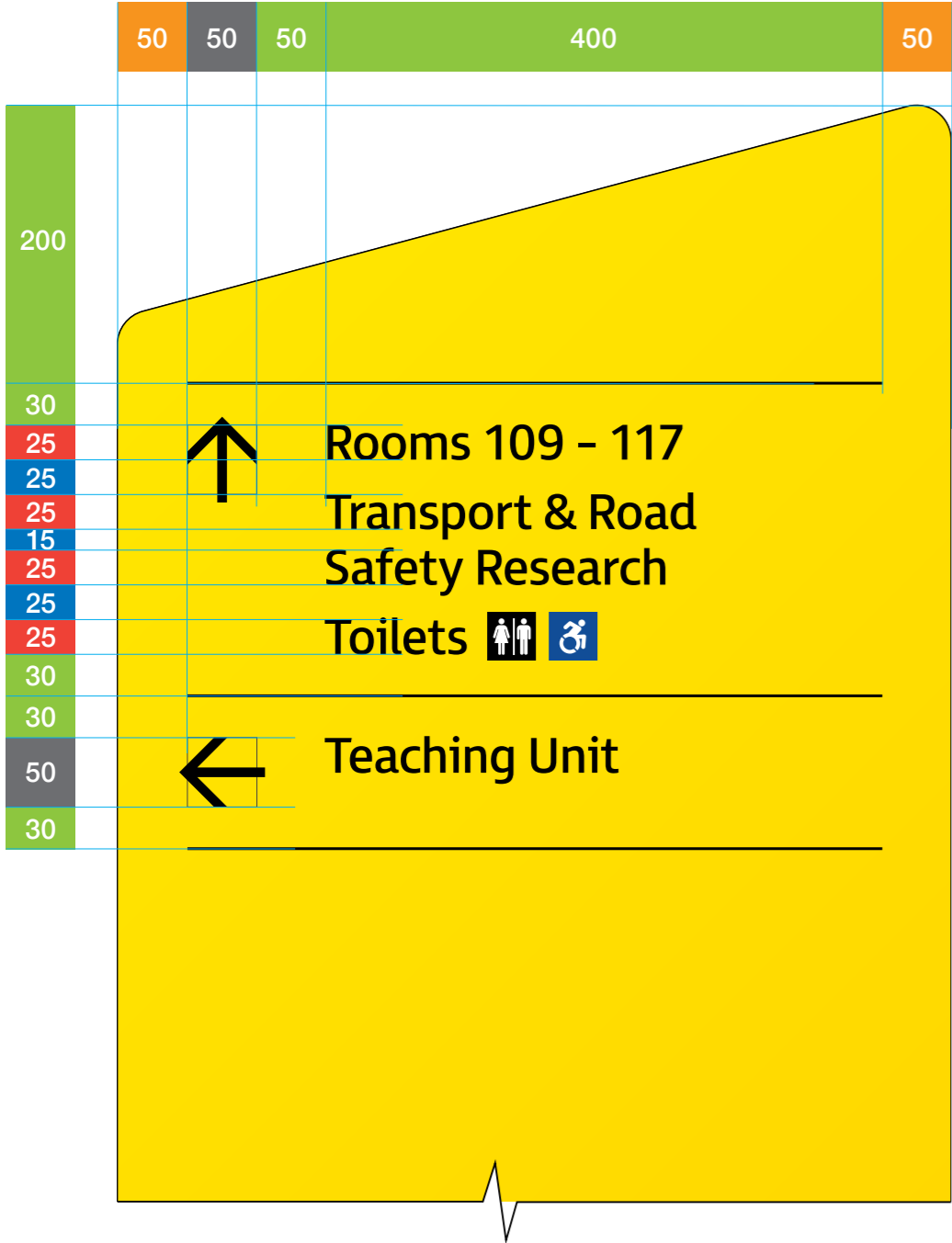

Note

Messaging layouts should be applied as the standard across all signage where relevant. Where text size is required to be smaller e.g. to accommodate longer names, any scaling must be done proportionally, and across all elements (text, arrows and pictograms).

DR.08 / DR.09 Internal Directional – Wall

- Cap Height: 25mm
- Leading: 25, 15mm
- Margins: 50mm
- Padding: 50, 30mm
- Arrow Height: 50mm

Scale 1:5

Section

8.0

Construction Standards

This section is an overview of the design intent and typical specifications of the various sign forms of the UNSW wayfinding system.

Finishes Schedule

Signage Heights & Standards

Totem Signforms

Layered Panel Signforms

Digital Signforms

Suspended Signforms







Cantilevered Signforms

Wall Mounted Signforms

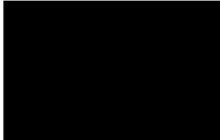
Direct Applied Graphics

Off-the-shelf

Finishes Schedule

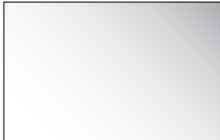
Code	Colour	Finish	Substrate & Notes
C1		<ul style="list-style-type: none"> Satin yellow two pack polyurethane finish to match UNSW Yellow – Pantone 108C Dulux Dandelion Yellow A205 	<ul style="list-style-type: none"> All relevant signs applied with two pack polyurethane finish specified colour to front surface and all edges of substrate
C2		<ul style="list-style-type: none"> Satin black two pack polyurethane finish to match Dulux Black SG6G9 	<ul style="list-style-type: none"> All relevant signs applied with two pack polyurethane finish of specified colour to front surface and all edges of substrate
C3		<ul style="list-style-type: none"> Satin red two pack polyurethane Dulux finish to match International 'Signal Red' R13 	<ul style="list-style-type: none"> All relevant signs applied with two pack polyurethane finish of specified colour to front surface and all edges of substrate
P1		<ul style="list-style-type: none"> Matte Wall Paint Dulux Dandelion Yellow A205 	<ul style="list-style-type: none"> Graphics applied as paint mask and spray directly onto wall substrate.
P2		<ul style="list-style-type: none"> Matte Wall Paint Dulux Domino SG6G8 	<ul style="list-style-type: none"> Graphics applied as paint mask and spray directly onto wall substrate.
P3		<ul style="list-style-type: none"> Matte Wall Paint Dulux Vivid White SW1G1 	<ul style="list-style-type: none"> Graphics applied as paint mask and spray directly onto wall substrate.
P4		<ul style="list-style-type: none"> Dulux Matte Wall Paint to match Accessible Blue (PMS 294) 	<ul style="list-style-type: none"> Graphics applied as paint mask and spray directly onto wall substrate.
A1		<ul style="list-style-type: none"> White opal acrylic 	<ul style="list-style-type: none"> Profile cut white opal acrylic to allow internal edge-lit illumination.







The specifications noted and signforms documented in Section 8 illustrate the design intent of typical signforms in relation to sign structure, fixings and illumination. The Signage Contractor is responsible for the detailed design development, documentation, shop drawings and certification of all components including all structural frames and connections. To be fit for purpose and comply with all relevant code, Building Code of Australia, and relevant Australian Standard requirements.

The codes within the table are grouped as per finish:
C = Coating finish (e.g. Two-pack Polyurethane)
P = Paint finish
A = Acrylic finish
V = Self-adhesive film finish
S = Screen print finish

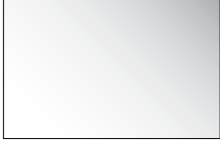
Refer to Sections 10 – 17 for a detailed breakdown of each sign type and its associated graphic and messaging layouts.

Refer to Appendix for standards on material specification

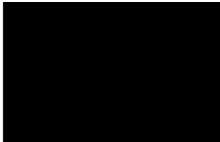
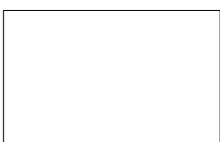
Finishes Schedule

Code	Colour	Finish	Substrate & Notes
A2		<ul style="list-style-type: none"> Clear acrylic 	<ul style="list-style-type: none"> Profile cut clear acrylic
A3		<ul style="list-style-type: none"> Yellow acrylic to match UNSW Yellow – Pantone 108C 	<ul style="list-style-type: none"> Profile cut yellow acrylic
A4		<ul style="list-style-type: none"> Perspex Cast Acrylic Sheet - Secret Sign 	
V1		<ul style="list-style-type: none"> Avery Primrose Yellow #707 	<ul style="list-style-type: none"> Profile cut self-adhesive film (use sustainable products where possible) in specified colour applied directly to front face of messaging panels/designated surface. All panels with film finished with protective clear coat where specified.
V2		<ul style="list-style-type: none"> Avery Matte Black #180 	<ul style="list-style-type: none"> Profile cut self-adhesive film (use sustainable products where possible) in specified colour applied directly to front face of messaging panels/designated surface. All panels with film finished with protective clear coat where specified.
V3		<ul style="list-style-type: none"> Avery Matte White #102 	<ul style="list-style-type: none"> Printed profile cut self-adhesive film (use sustainable products where possible) in specified colour or graphics applied directly to front face of messaging panels/designated surface. All panels with film finished with protective clear coat where specified.
V4		<ul style="list-style-type: none"> Avery SF100 Ultra Clear 	<ul style="list-style-type: none"> Digital print to profile-cut self-adhesive film applied to glazing surfaces as required.
S1		<ul style="list-style-type: none"> Digital screen print to substrate 	<ul style="list-style-type: none"> Graphics to be digitally printed to substrate (e.g. opal acrylic), with double print as required to ensure opacity and clarity.

The specifications noted and signforms documented in Section 8 illustrate the design intent of typical signforms in relation to sign structure, fixings and illumination. The Signage Contractor is responsible for the detailed design development, documentation, shop drawings and certification of all components including all structural frames and connections. To be fit for purpose and comply with all relevant code, Building Code of Australia, and relevant Australian Standard requirements.

The codes within the table are grouped as per finish:
C = Coating finish (e.g. Two-pack Polyurethane)
P = Paint finish
A = Acrylic finish
V = Self-adhesive film finish
S = Screen print finish

Refer to Sections 10 – 17 for a detailed breakdown of each sign type and its associated graphic and messaging layouts.

Refer to Appendix for standards on material specification

Signage Heights & Standards

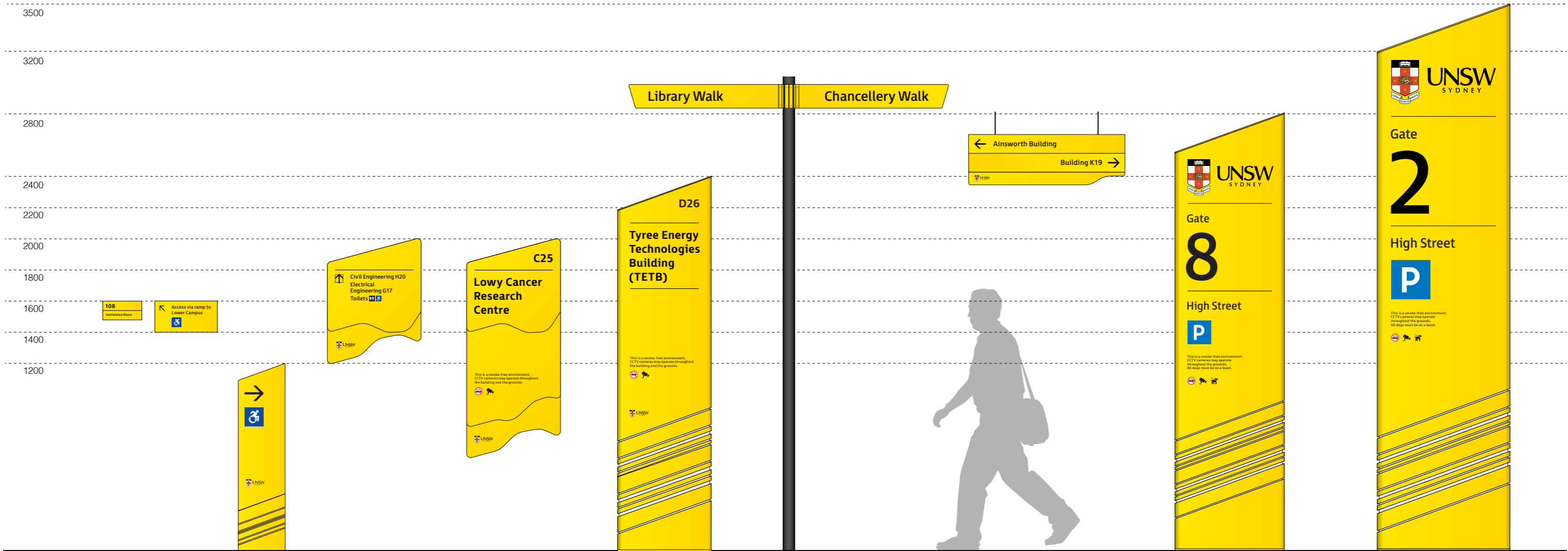

Signage heights
Scale 1:25

Totem Signforms: Sizes

There are three totem sizes that all freestanding types fit within, from a 2400mm high directional to a 3500mm high vehicular entry ID, depending on their function, necessary reading distance and viewing height.

Size A
600mm wide panel

Size B
700mm wide panel

Size C
850mm wide panel

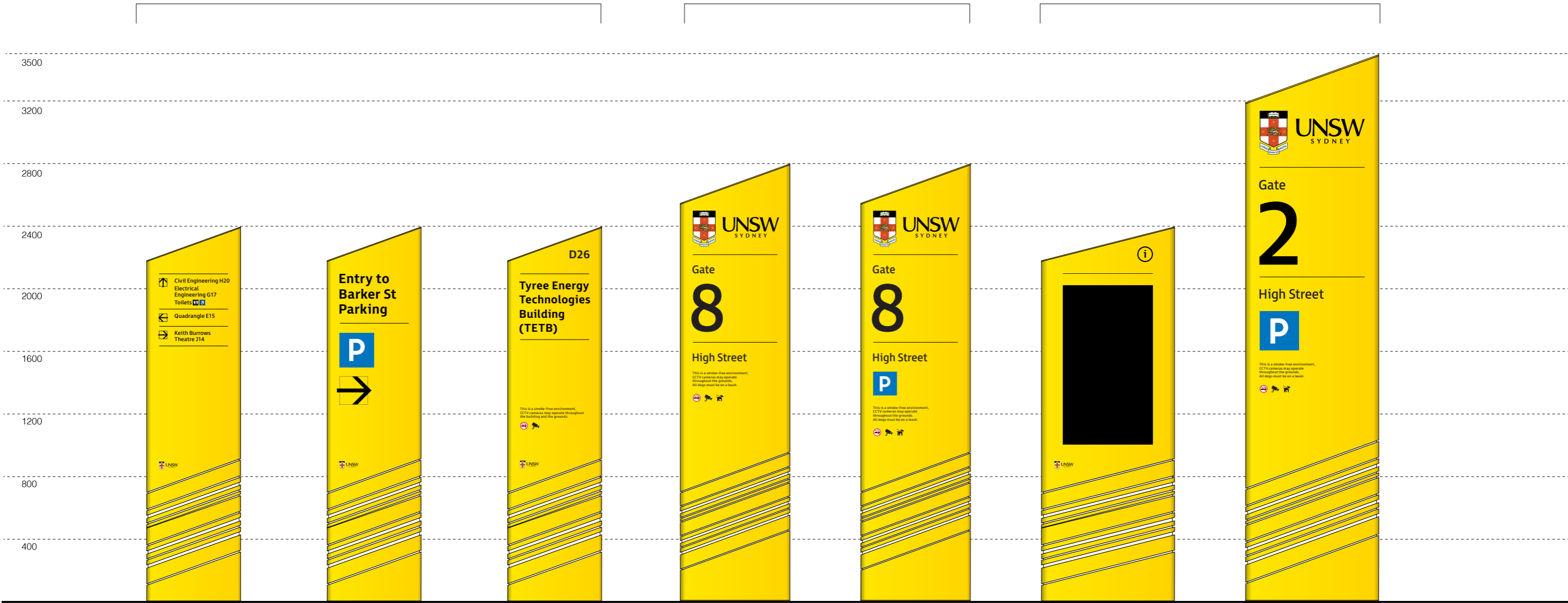

Totem heights
Scale 1:25

Totem Signforms: Panel Assembly

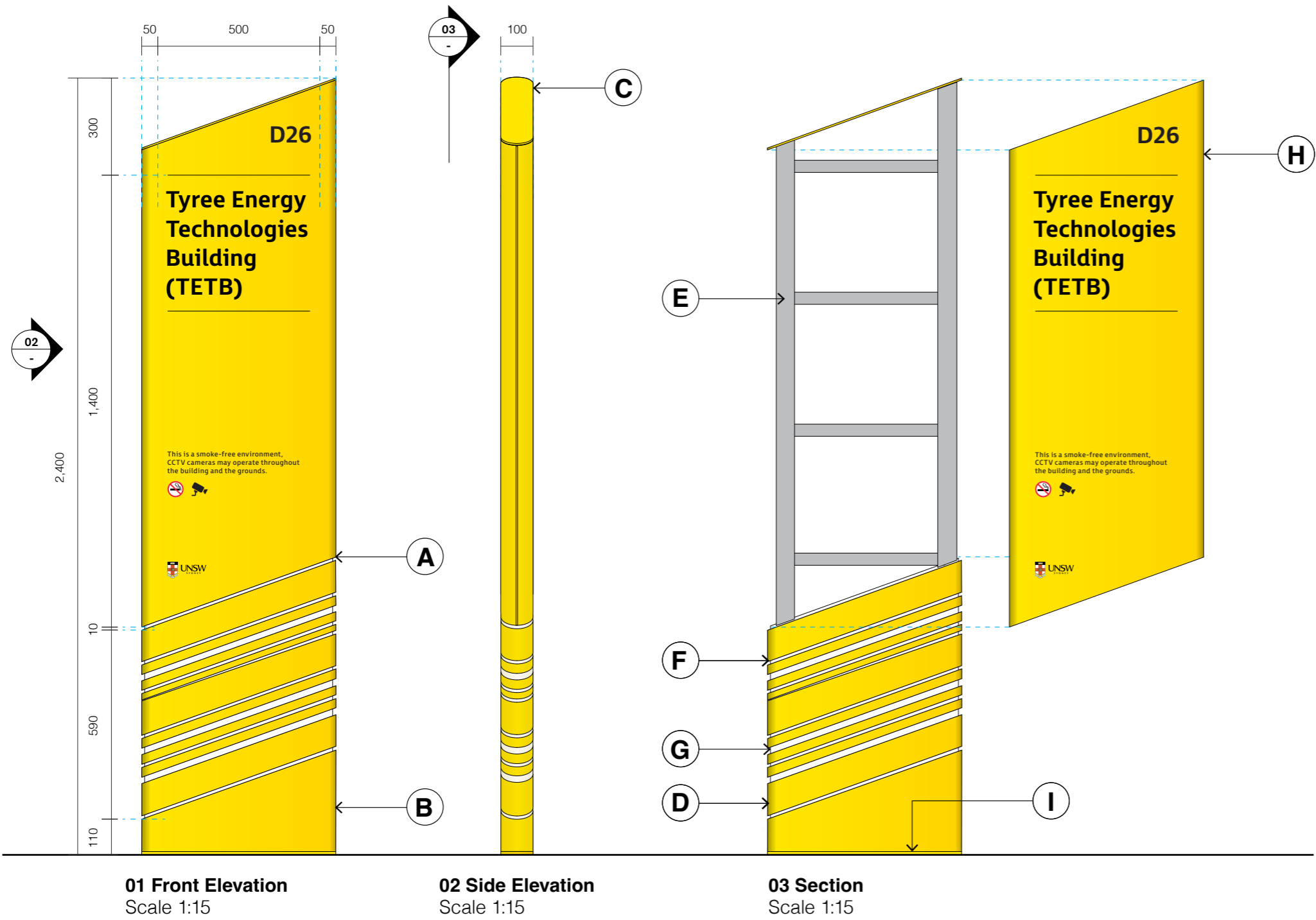

Construction Details

- A Junction shadow gap**
10mm shadow gap at junction of totem body and totem base to be in C1 finish.
- B Kickplate**
100mm high kickplate with 10mm shadow gap at base, both in C1 finish.
- C Totem side profile**
100mm wide side profile with 50mm radius rounded corners.
- D Totem form**
3mm thk aluminium extrusion in C1 finish.
- E Internal steel subframe**
Structural steel frame to be suitably rustproof, and as required for panel size and totem height.
- F Totem base etching**
Etched 10mm routed recess filled with white paint
- G Totem base lighting**
LED strip lighting in nominal 10mm recess with 10mm formed acrylic split diffuser, adhesive fixed with silicone.
- H Removable messaging panel**
3mm curved aluminium panel in C1 finish, conceal fixed to internal frame. Fixings to be on totem side profile as shown in 02 Side Elevation.
- I Junction to ground**
Totem form to continue to ground plane. Where not possible, contractor to infill junction with matte black aluminium to conceal internal framing.

Totem Signforms: Construction Details

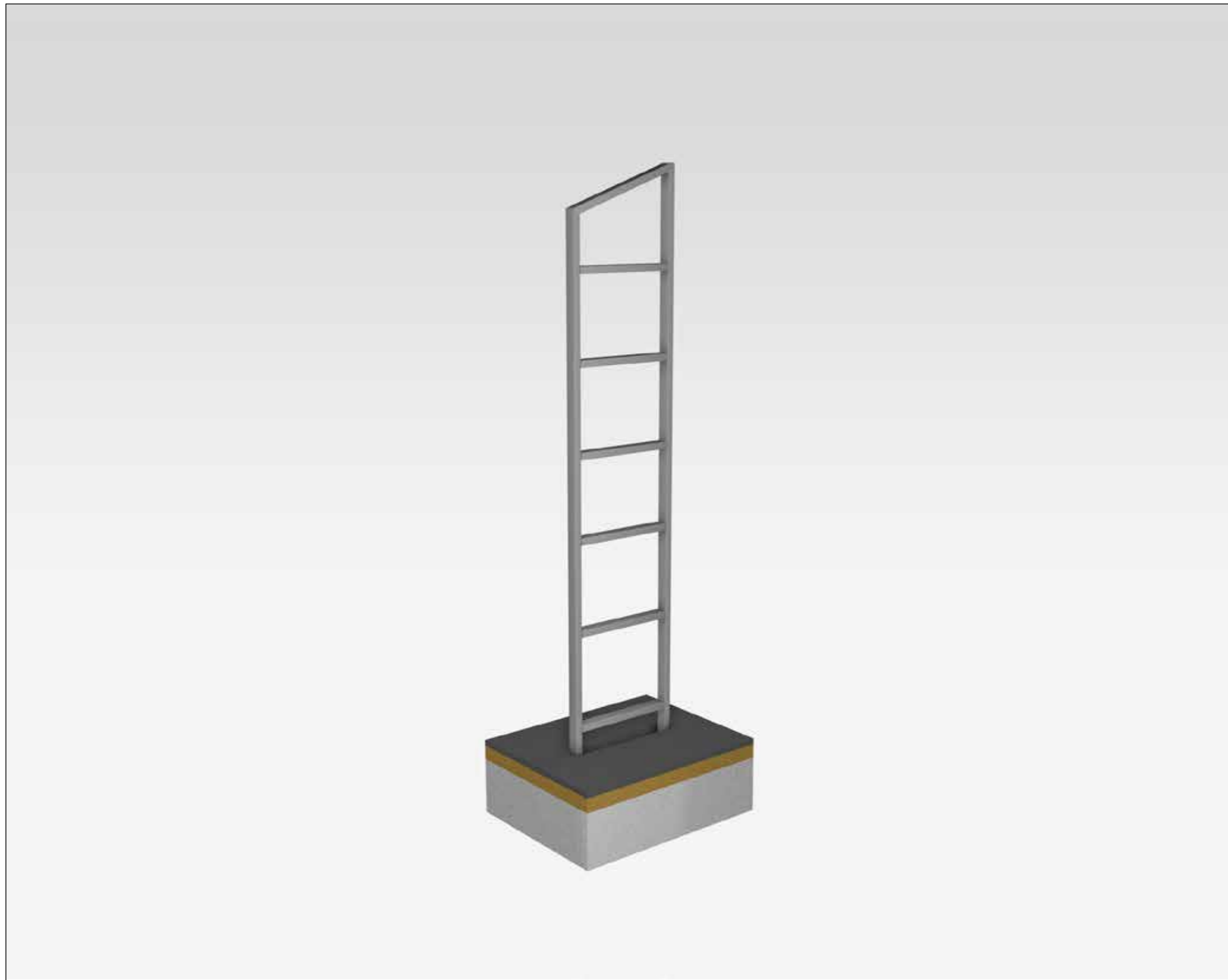

These pages provide a diagrammatic representation of the totem's construction.

Totem to be supported by RHS steel subframe or similar, fixed into ground plane. Signage contractor to advise and provide shopdrawings.

Totem Signforms: Construction Details

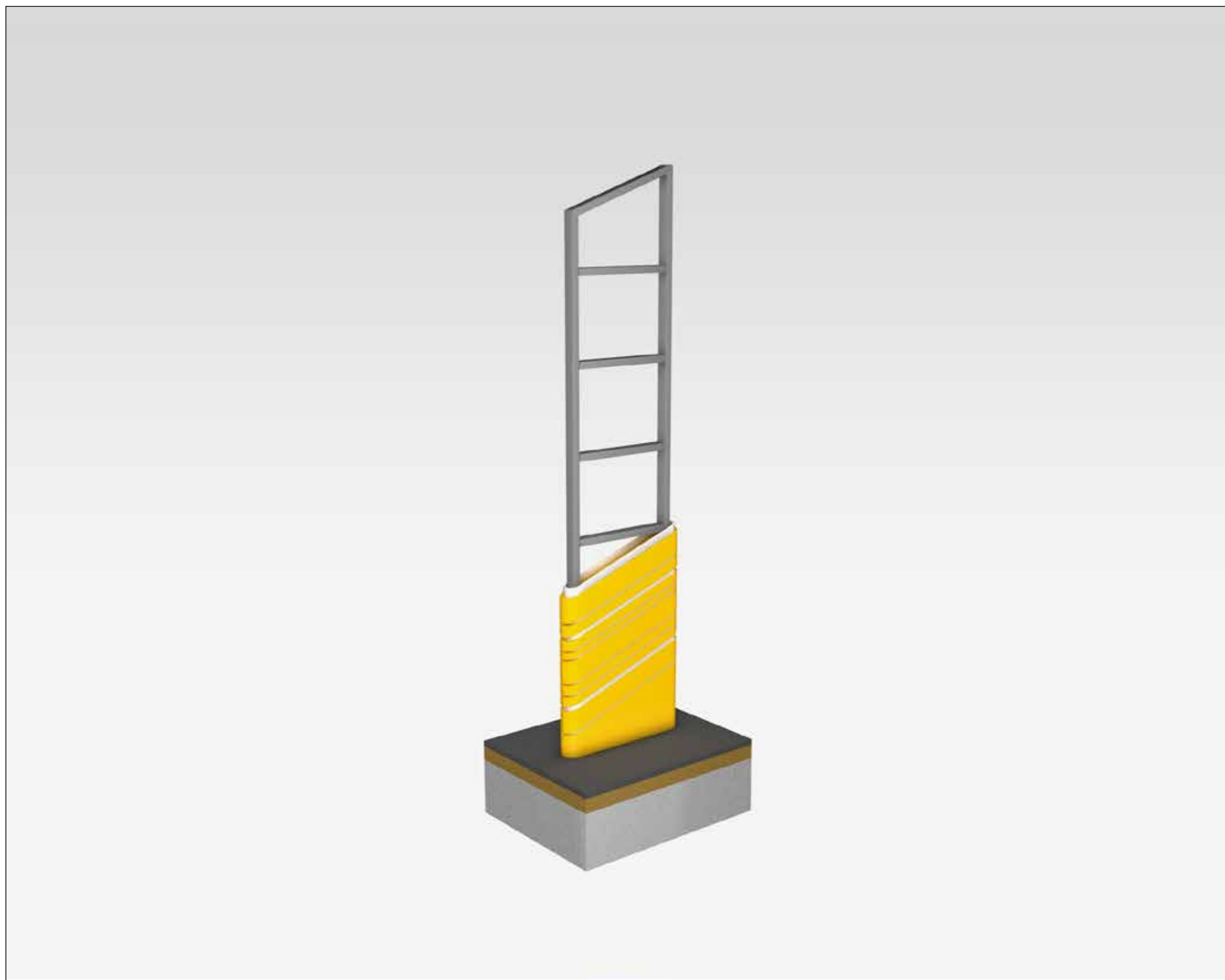

These pages provide a diagrammatic representation of the totem's construction.

Totem base to be 3mm thk formed aluminium with 100mm kickplate to base. Base is to be assembled in two halves, with LED illumination and formed acrylic diffuser set into nominated recesses.

Totem Signforms: Construction Details



These pages provide a diagrammatic representation of the totem's construction.

Totem messaging panels to be 3mm thk formed aluminium, with internal plywood backing, contractor to advise fixing method. Panel fixings to be located on totem side profile, with 5mm shadow gap between panels.

Totem Signforms: Construction Details

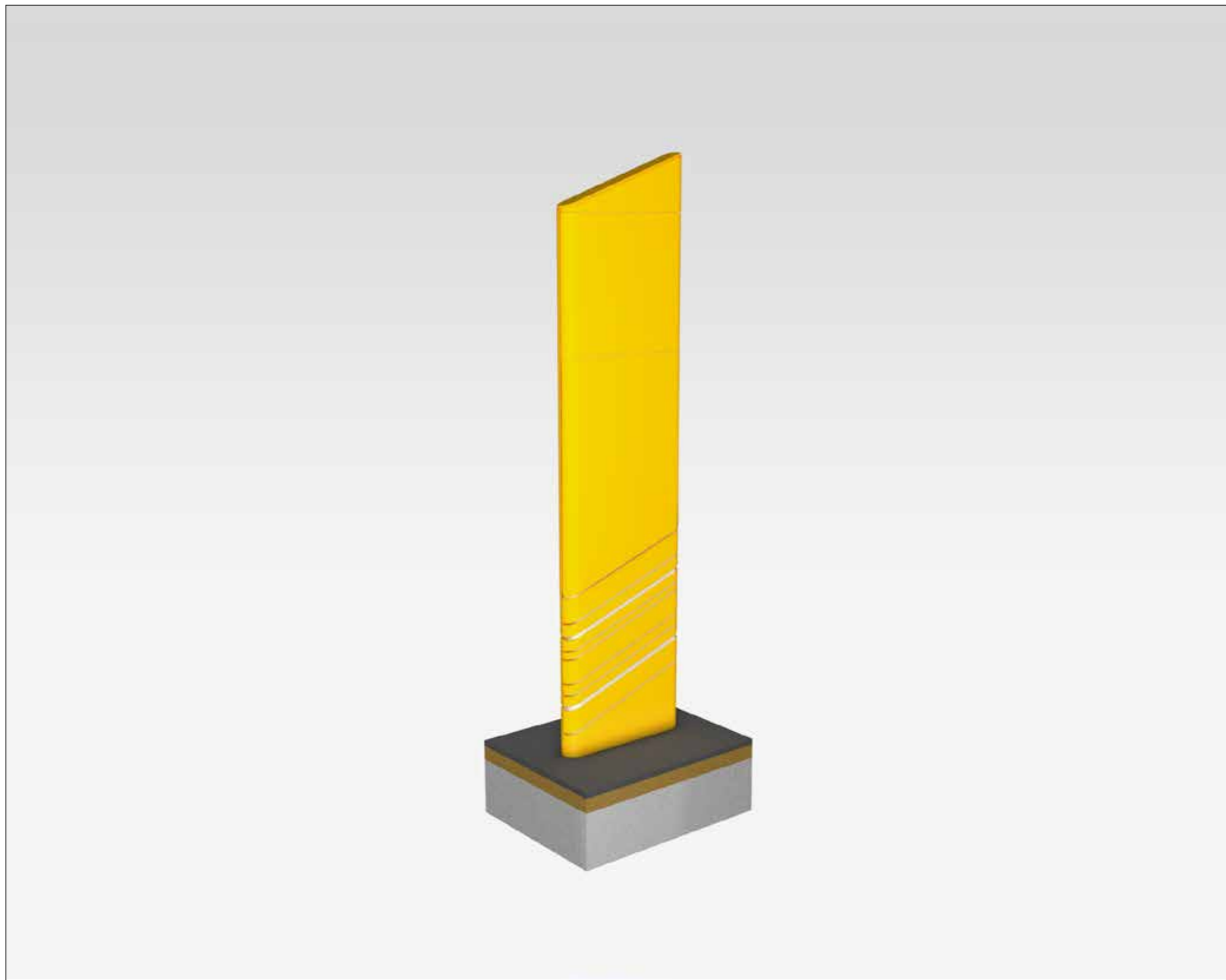

These pages provide a diagrammatic representation of the totem's construction.

Totem is to have a 10mm shadow gap at the junction between messaging panels and the base, as well as a 10mm shadow gap at the kickplate's base.

Totem Signforms: Construction Details



These pages provide a diagrammatic representation of the totem's construction.

Totem messaging is to be applied as self-adhesive film, screenprint, or profile-cut illuminated opal acrylic as specified.

Totem Signforms: Construction Details

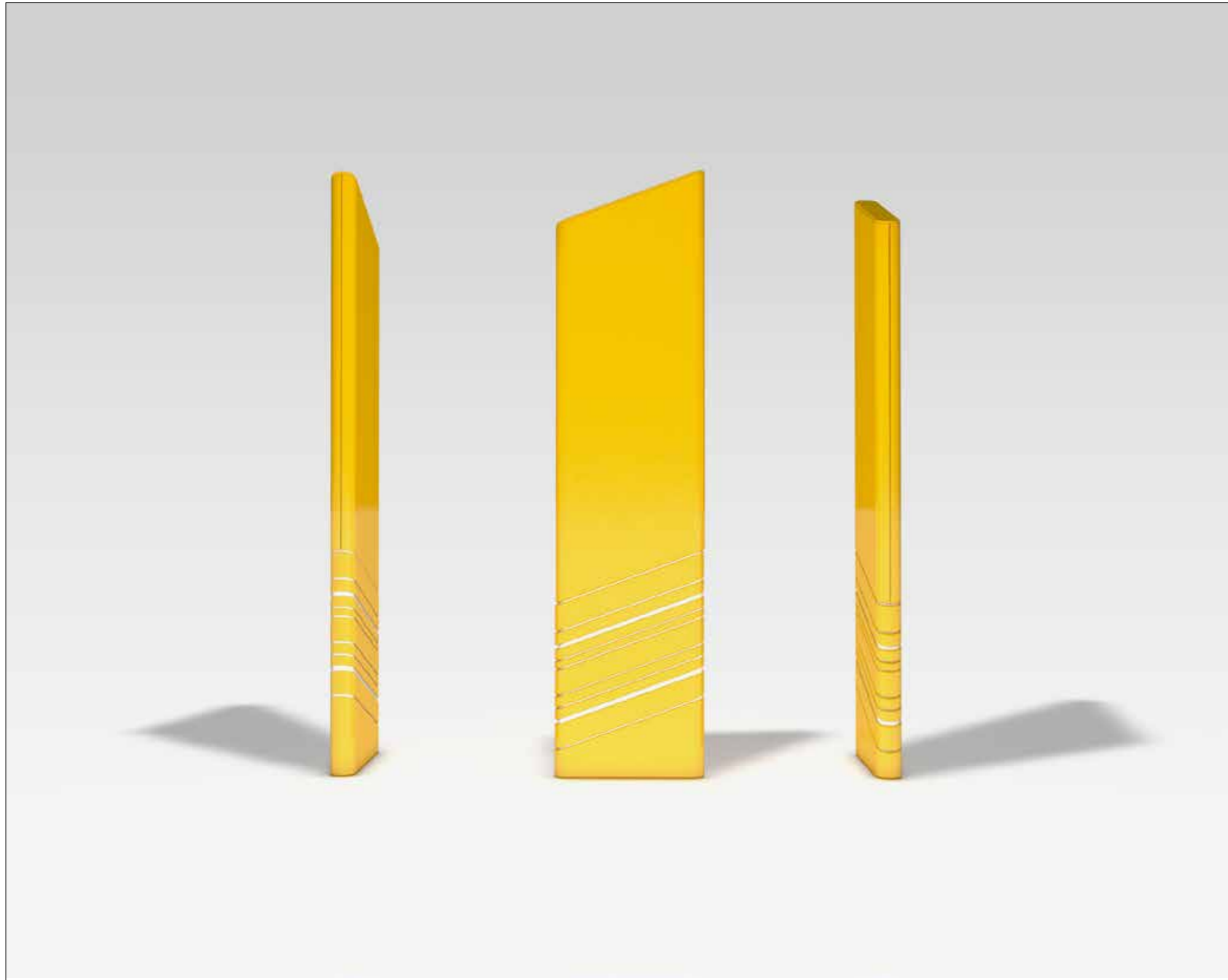

These pages provide a diagrammatic representation of the totem's construction.

All angles within the totem's form - endcap, junctions, and linework, are at 20 degrees.

Layered Panel Signforms: Sizes

There are two sizes that typical wall mounted directional signage fit within, from a 800mm high panel to a 1400mm high panel, depending on their function, necessary reading distance and viewing height.

Size A
800mm length panel

Size B
1400mm length panel



Layered panel heights
Scale 1:25

Layered Panel Signforms: Panel Assembly

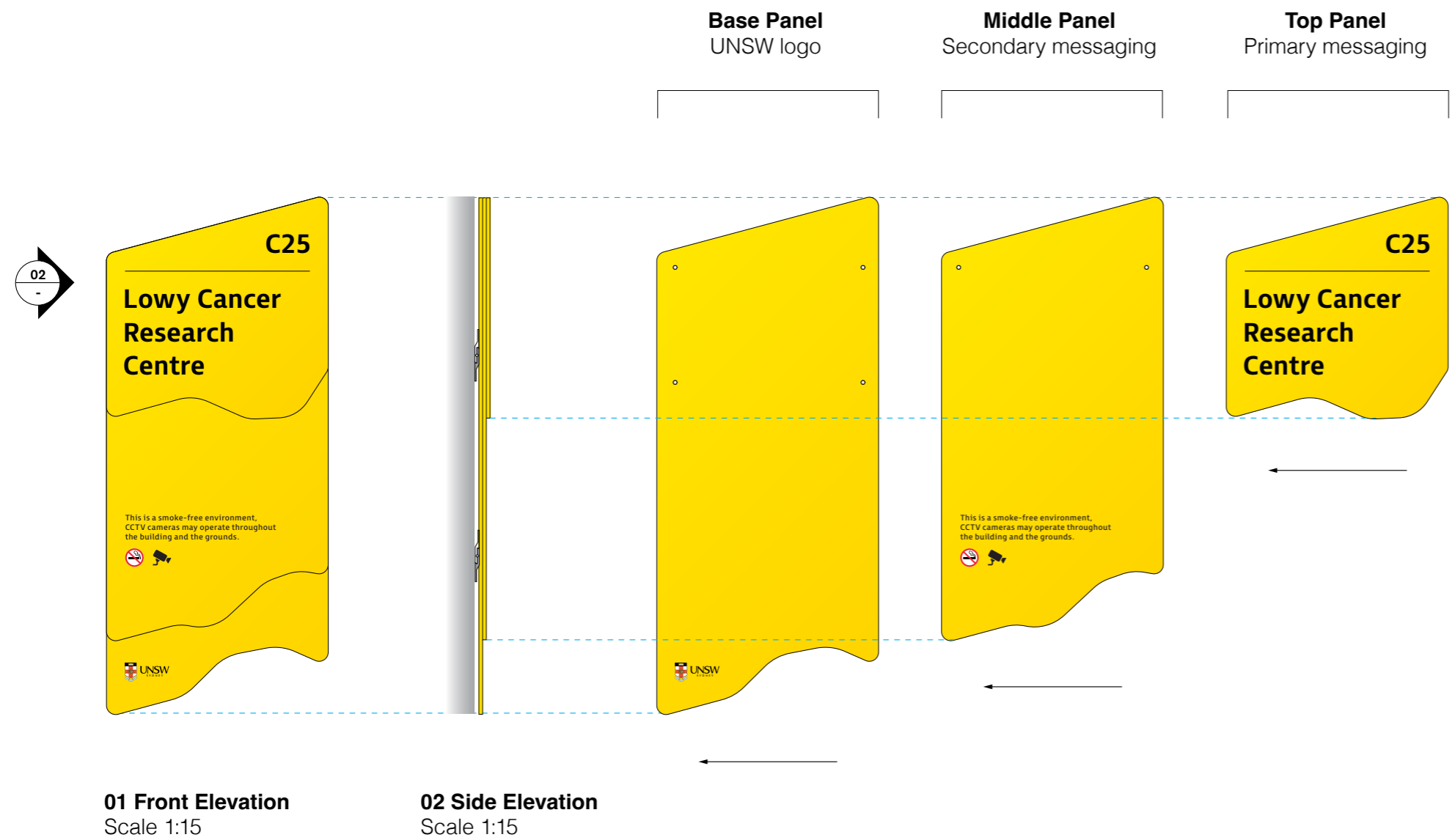

Modular system overview

The layered signform family is designed to allow for a wide range of directional and identification purposes, while maintaining the unified design of all sign types. Up to three panels can be stacked using a mounting pin method that is easily removable, to allow for changed messaging or graphics.

This diagram illustrates the stacking method used for each signform. Mounting pin locations are shown indicatively, with the intent being that they are hidden from view to create a seamless look.

Digital Signforms: Totem

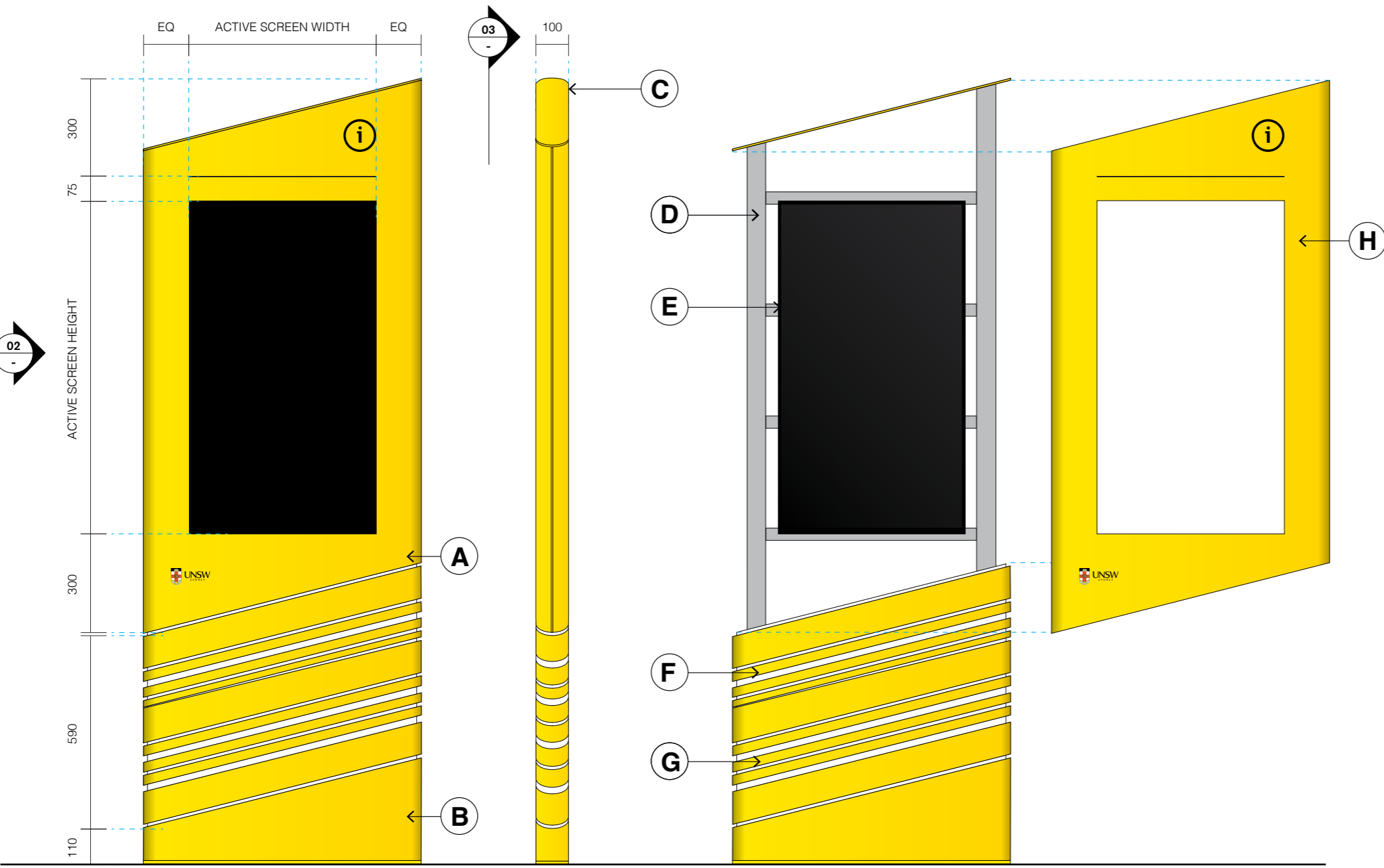

01 Front Elevation
Scale 1:15

02 Side Elevation
Scale 1:15

03 Section
Scale 1:15

Construction Details

- A Junction shadow gap**
10mm shadow gap at junction of totem body and totem base.
- B Kickplate**
100mm high kickplate with 10mm shadow gap at base.
- C Totem side profile**
100mm wide side profile with 50mm radius rounded corners.
- D Internal steel subframe**
Structural steel frame to be suitably rustproof, and as required for panel size and totem height.
- E Digital screen**
Screen specifications TBC by UNSW pending requirements. Screen unit subframe fixed to internal steel structure, accessible from front.
- F Totem base etching**
Etched 10mm routed recess filled with white paint
- G Totem base lighting**
LED strip lighting in nominal 10mm recess with 10mm formed acrylic split diffuser, adhesive fixed with silicone.
- H Removable messaging panel**
3mm curved aluminium panel in C1 finish, conceal fixed to internal frame. Fixings to be on totem side profile as shown in 02 Side Elevation.

Digital Signforms: Wall Mounted

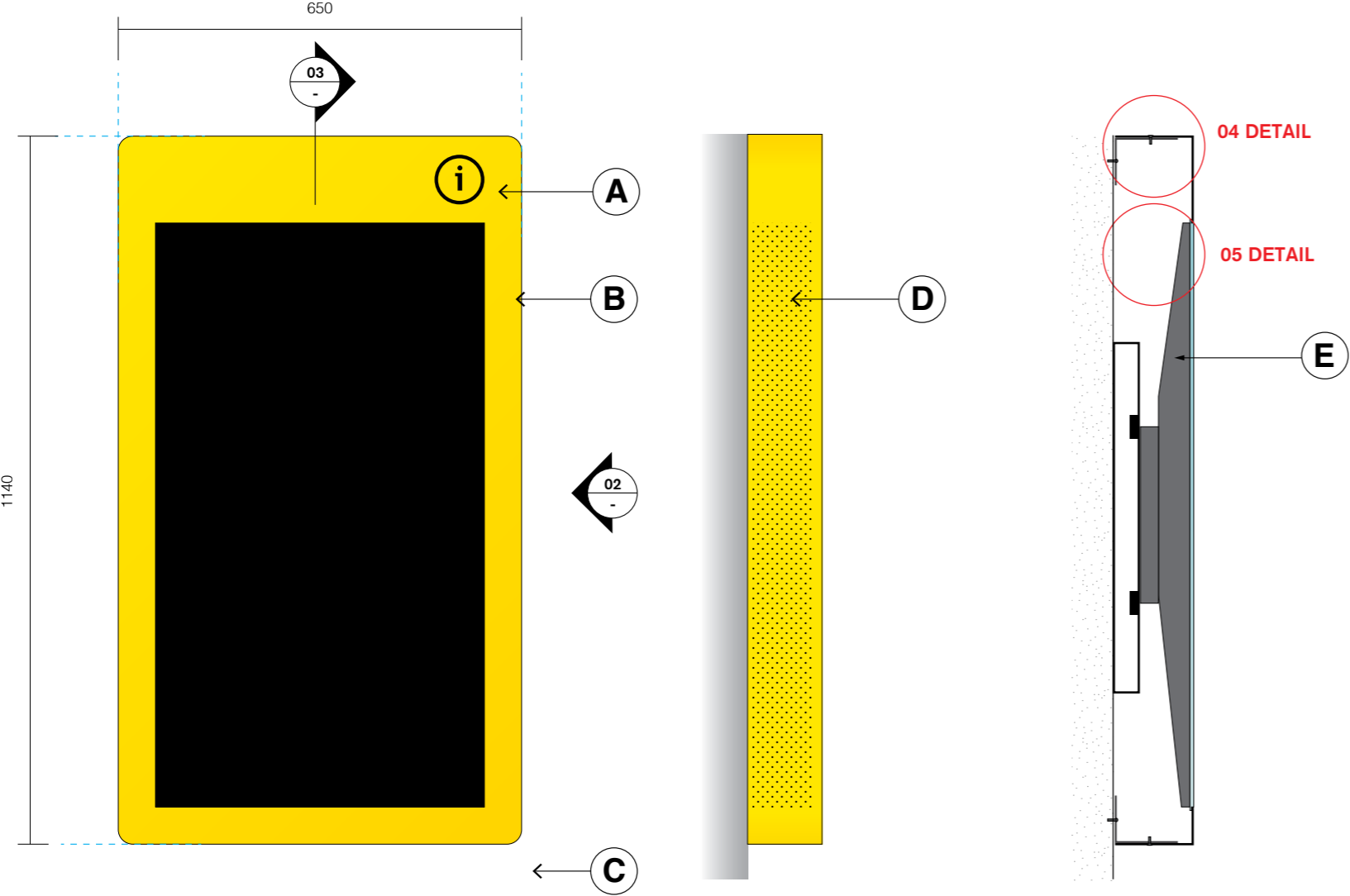

01 Front Elevation
Scale 1:10

02 Side Elevation
Scale 1:10

03 Section
Scale 1:10

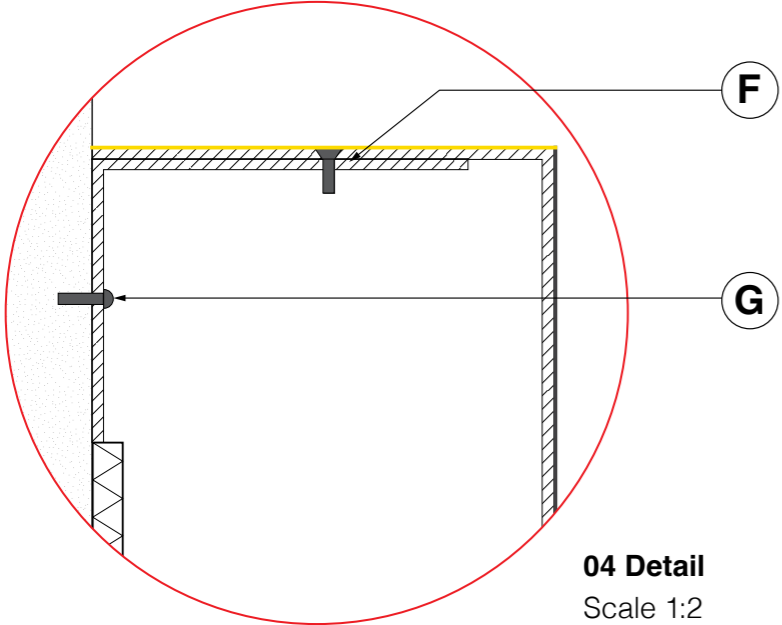

04 Detail
Scale 1:2

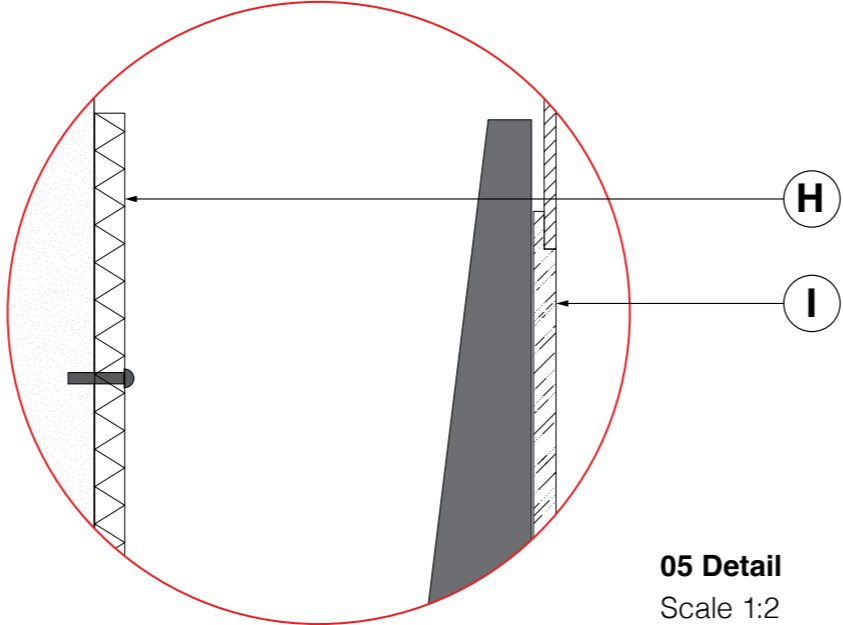

05 Detail
Scale 1:2

Construction Details

- A Icons**
Matte black self-adhesive film applied to surface.
- B External frame**
3mm aluminium frame in C1 finish.
- C Frame corners**
25mm radius on all frame corners
- D Perforations**
Perforation to allow for proper ventilation. Contractor to ensure perforations are bug, weather and dust proof.
- E Digital screen**
Screen specifications TBC by UNSW pending requirements.
- F Subframe**
3mm aluminium subframe. External frame fixed with countersunk screws in C1 finish.
- G Wall fixing**
Flush fixed to wall substrate. Nominal nylon anchor fixing. Contractor to advise fixing method.
- H Backing board**
10mm backing board to support screen mount.
- I Acrylic cover**
Digital screen to sit behind high impact 6mm thick clear acrylic with 3mm deep routing, 5mm from edge to allow flush alignment with opening of aluminium cover.

Suspended Signforms: Panel Assembly

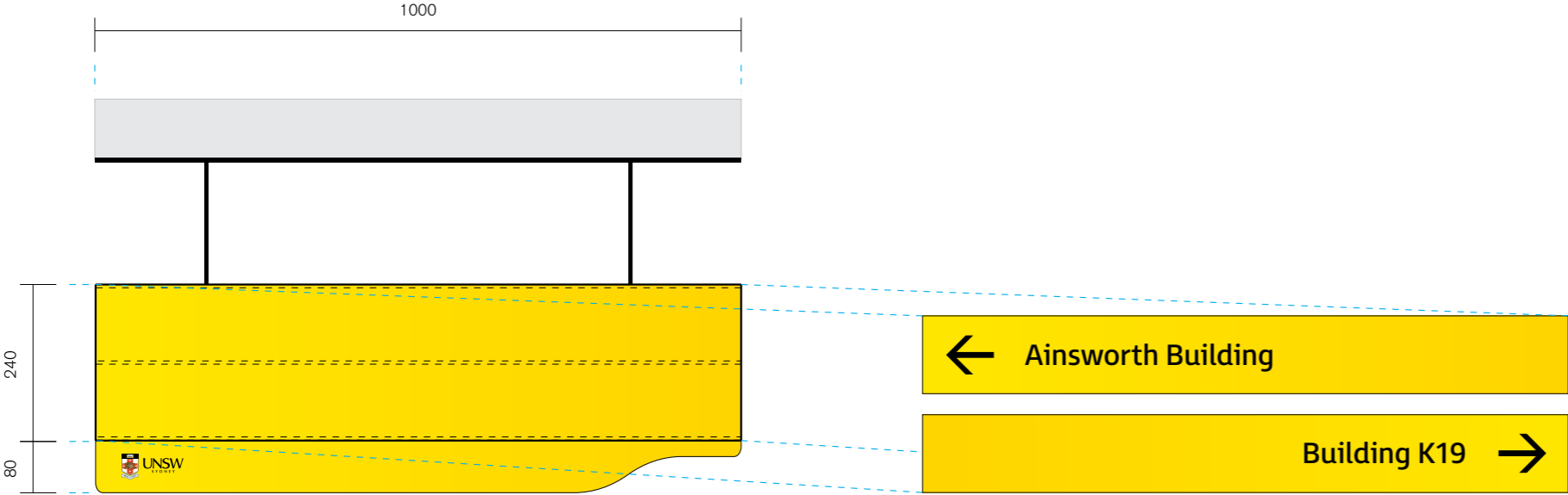

01 Elevation - Two panels
Scale 1:10

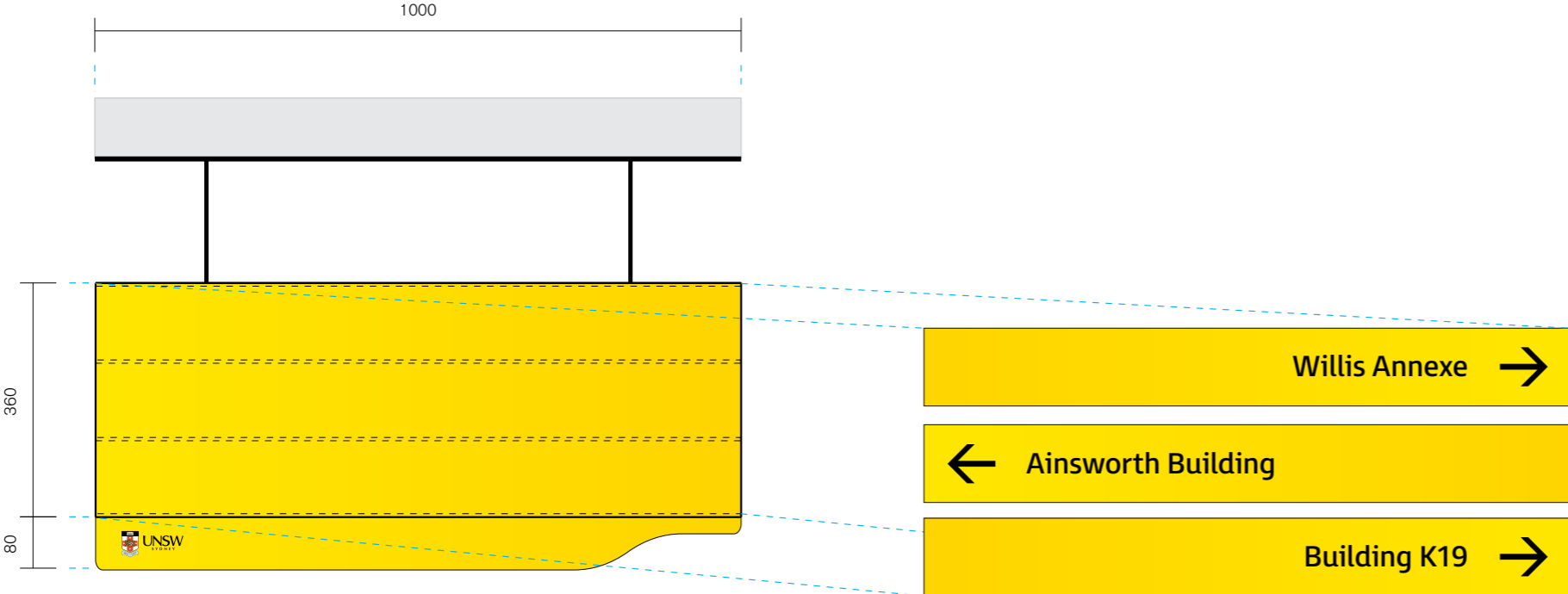

02 Elevation - Three panels
Scale 1:10

Suspended system overview

The suspended signform family allows for easily changeable directional messaging within a system that allows either two or three destinations. Panels clip into a central core panel, allowing for minimal fixings that can be easily removed and changed.

Suspended Signforms: Construction Details

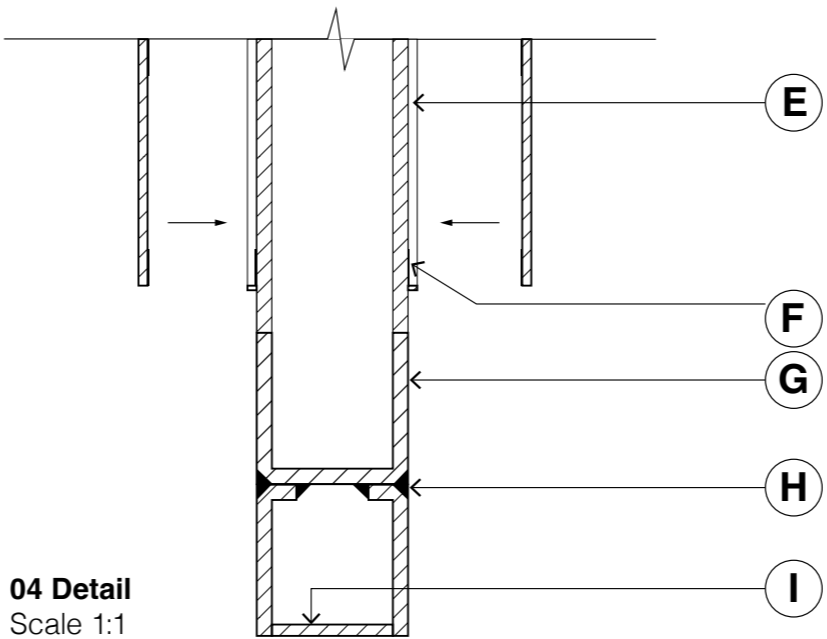
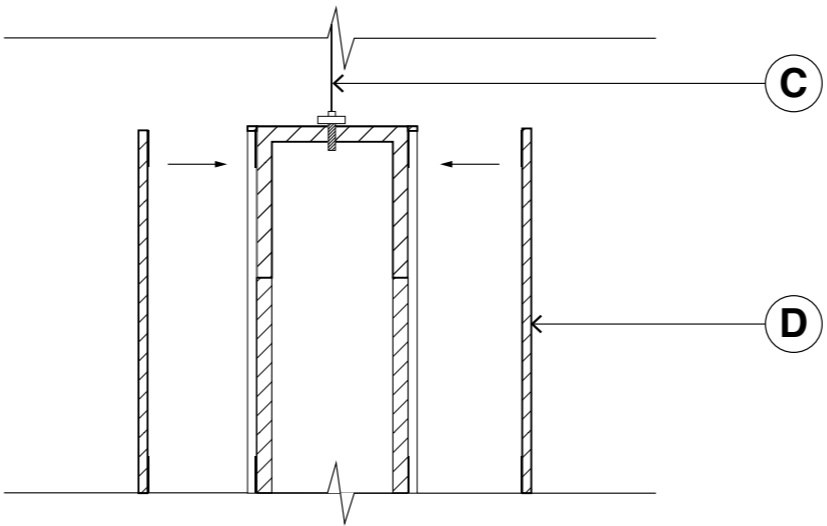
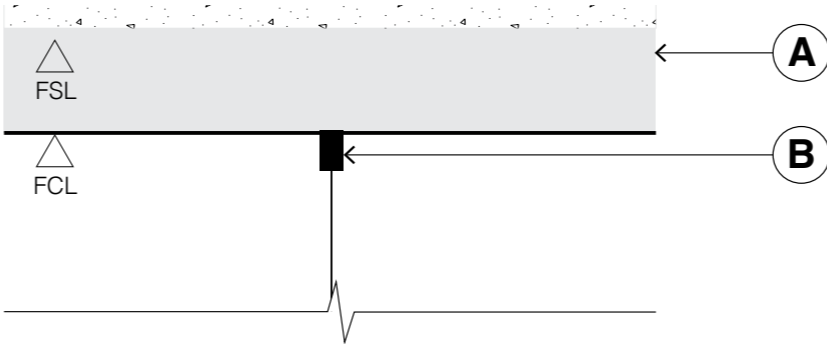
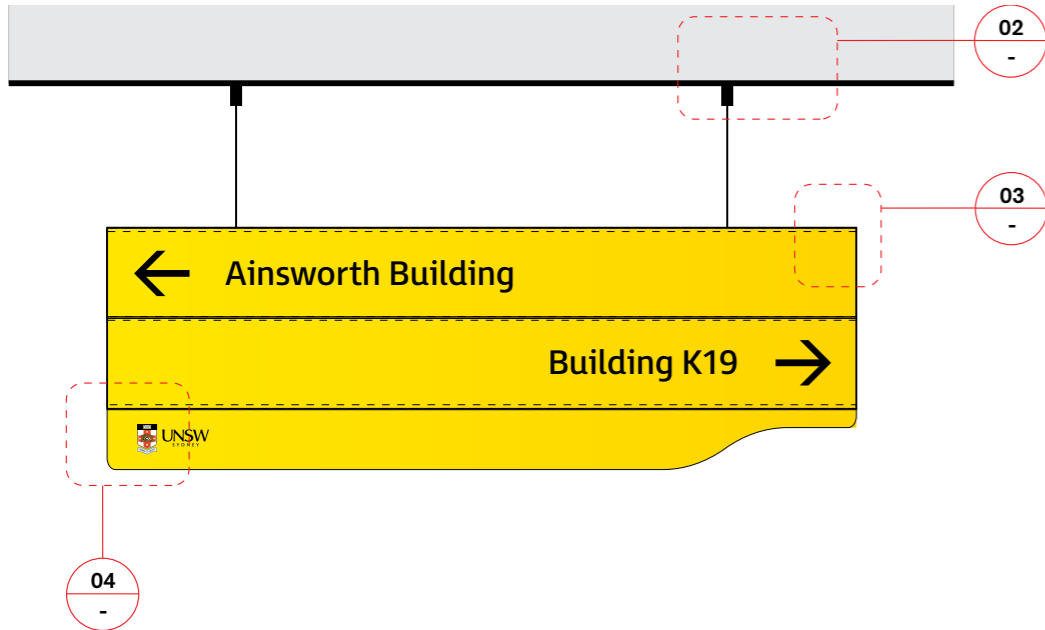

Construction Details

- A Ceiling slab**
Unknown ceiling substrate, contractor to confirm on site as per location of sign type.
- B Ceiling slab fixing**
Suspension system fixed to ceiling slab as determined by contractor. Ceiling construction is varied across locations, contractor to determine best method for fixing of suspension system.
- C Suspension system**
Min 3mm thick stainless steel suspension system conceal fixed to top of sign. Sign to sit at minimum 2400 FFL.
- D Messaging panel**
Removable 1mm aluminium messaging panel in finish C1, magnetically fixed to core section.
- E Extruded frame**
1mm wide extruded frame to hold removable messaging panels, finished to match core section.
- F Magnetic fixings**
Magnetic fixings to be positioned on core panel as advised by contractor.
- G Core section**
Core section as 20mm aluminium extrusion with C1 finish.
- H Curved profile**
Folded profile-cut aluminium welded to core aluminium extrusion in finish C1. All visible weld joints to be ground clean.
- I End cap**
Formed aluminium flat bar welded as end cap in finish C1.

Cantilevered Signforms: Amenity Blade



Cantilevered system overview

The cantilevered signform is used for amenity identification. Both the 500mm and 330mm version are designed to sit flush with the corresponding wall surface they are mounted to.

Cantilevered Signforms: Amenity Blade

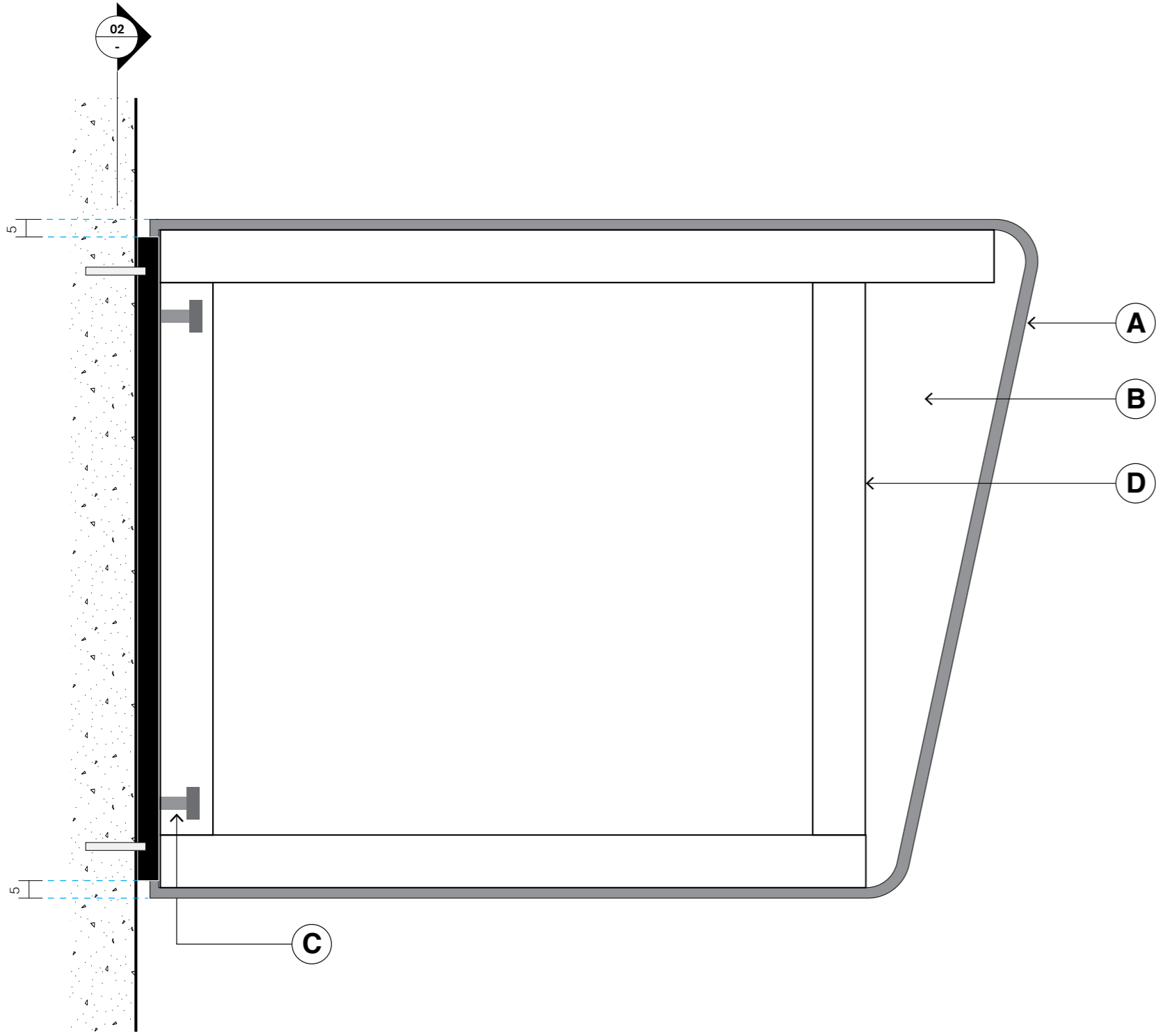

01 Section
Scale 1:2

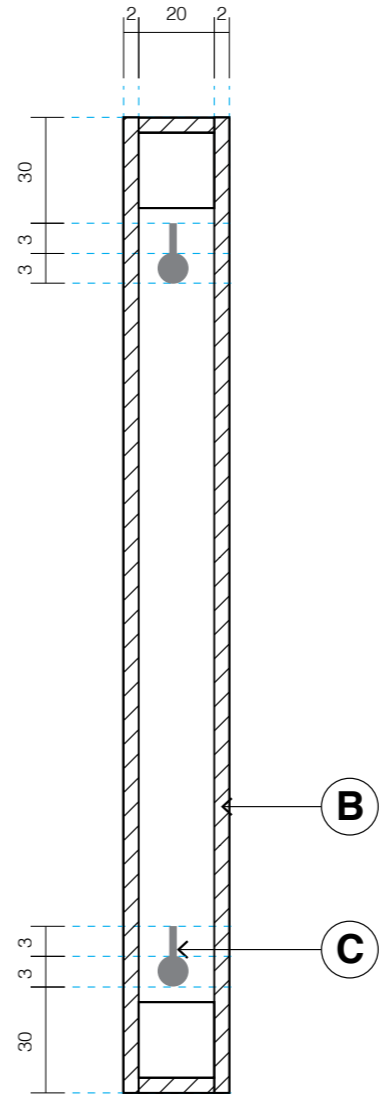

02 Section
Scale 1:2

Construction Details

- A Signform edges**
2mm folded aluminium edge panel adhesive fixed to subframe in C1 finish.
- B Signform face**
2mm aluminium panel adhesive fixed to subframe in C1 finish.
- C Keyhole fixing**
Subframe keyhole fixed to base, mechanically fixed flush to wall substrate. Contractor to determine fixing method following review of sign type locations.
- D Internal subframe**
20x20mm square hollow section subframe, keyhole fixed to signform base.

Cantilevered Signforms: Pole

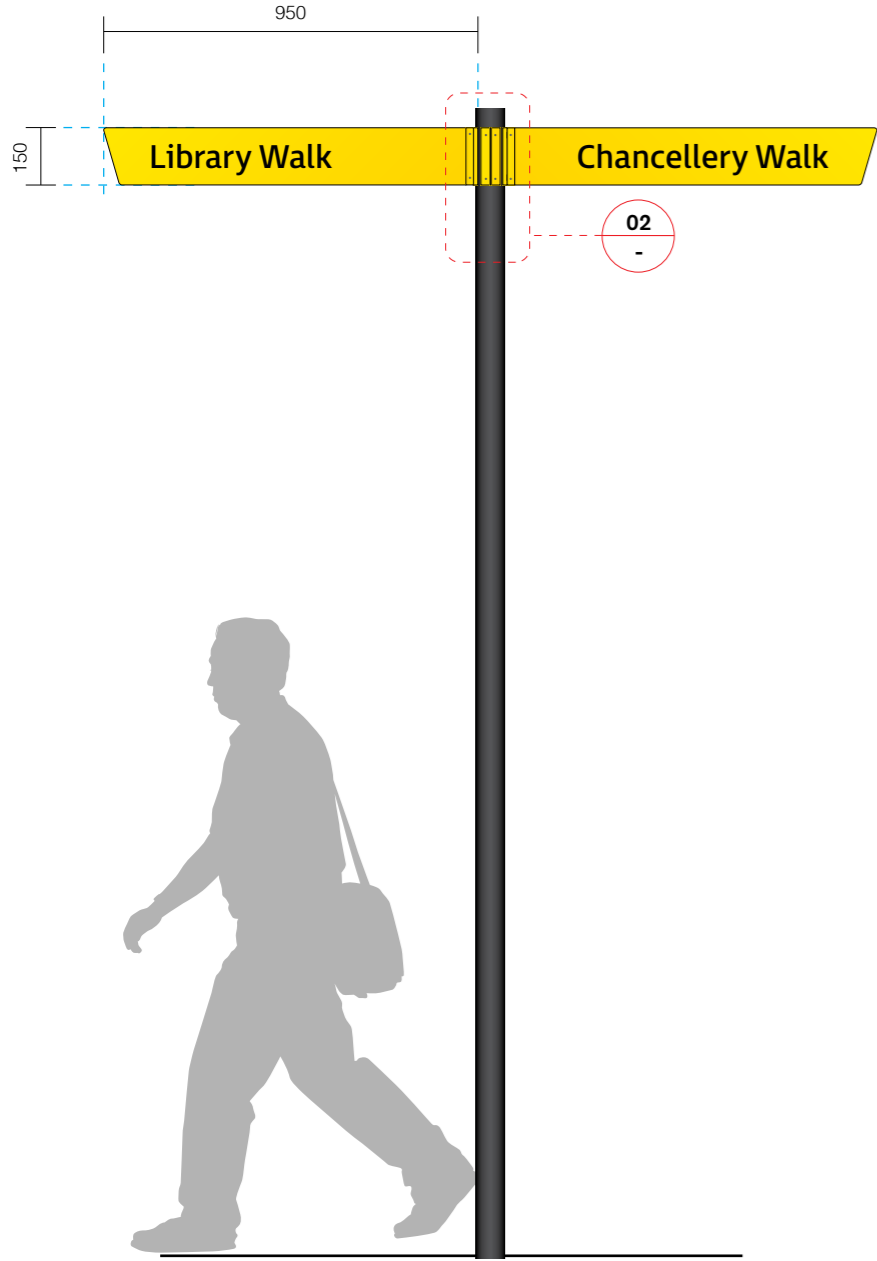

01 Elevation
Scale 1:20



02 Elevation
Scale 1:10

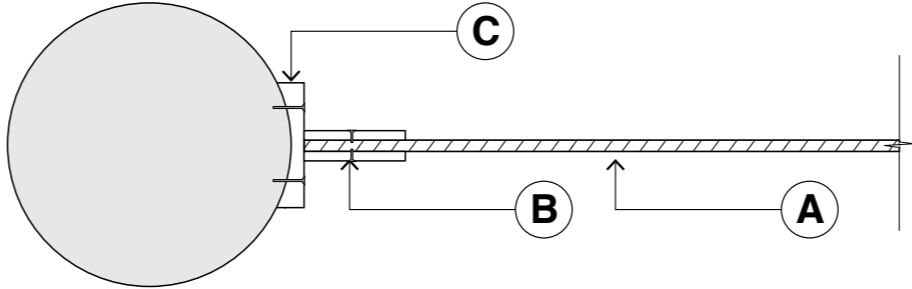

03 Plan
Scale 1:2

Construction Details

- A Messaging panel**
3mm aluminium panel finished in C1
- B Panel fixing**
Wing bracket fixing to pole, size of bracket to match messaging panel height, finished to match C1.
- C Pole fixing**
Mechanically fixed to existing campus street sign poles, contractor to advise fixing method.

Wall Mounted Signforms: Room ID System

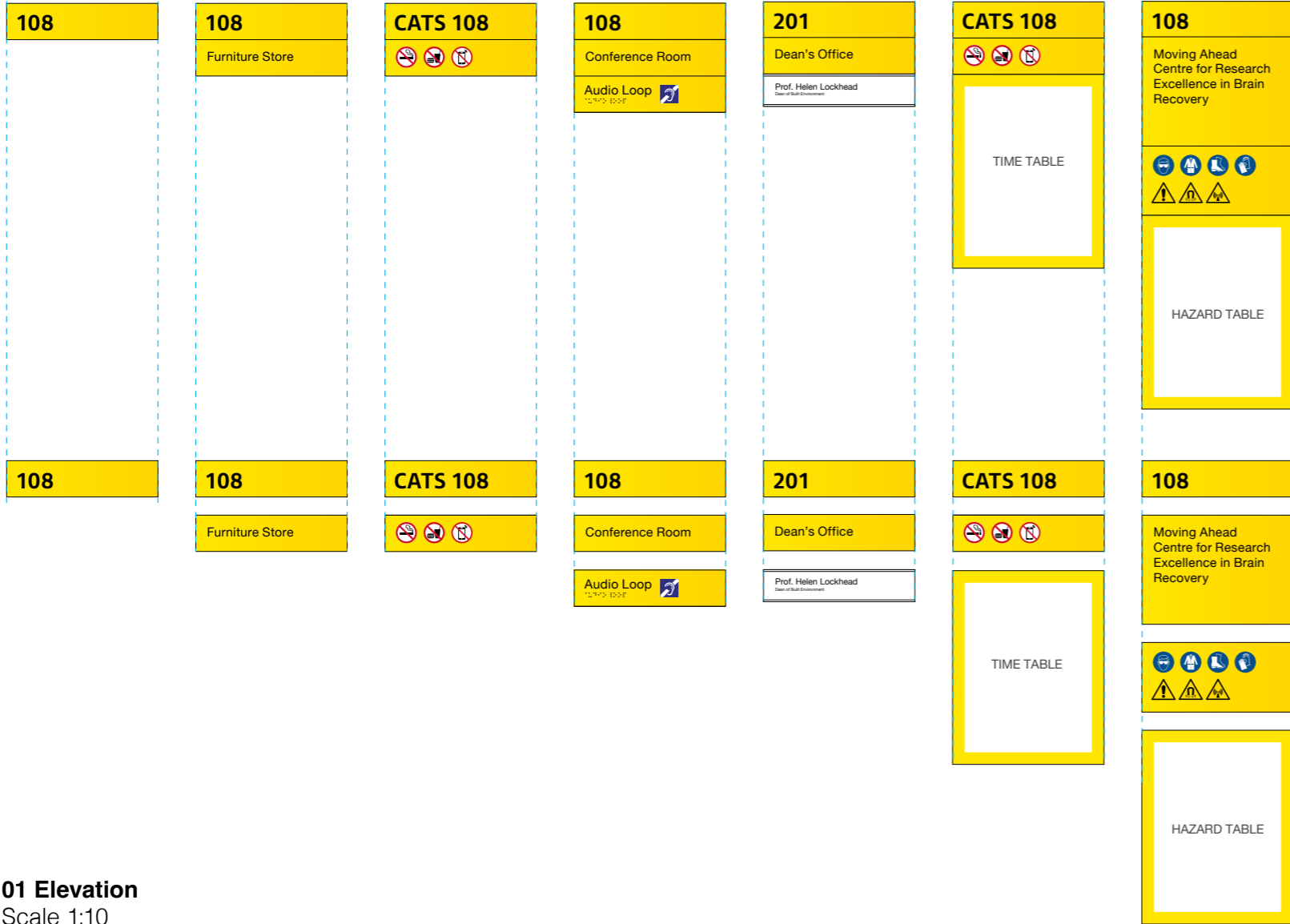

01 Elevation
Scale 1:10

Room ID system overview

The room identification system is designed to create a modular family of signforms that work together to provide necessary identification, statutory, and facility information about classrooms, laboratories, studios, and other rooms around campus.

The provided kit of parts includes room names, numbers, accessibility information, safety pictograms, occupant nameplates, and frames for timetables or hazard sheets. These components, made from aluminium panels, then stack as required to create a unified identification system for rooms.

Refer to sign type drawings for all variation of Room ID signage and messaging.

Wall Mounted Signforms: Fixing Methods

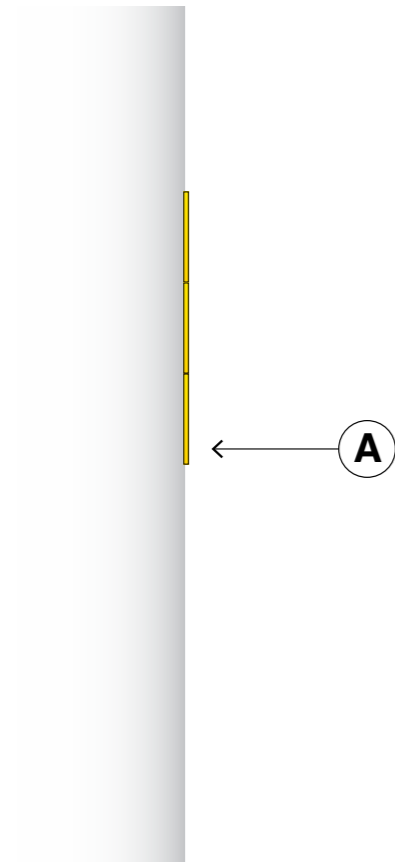

01 Elevation
Wall-mounted
Scale 1:5

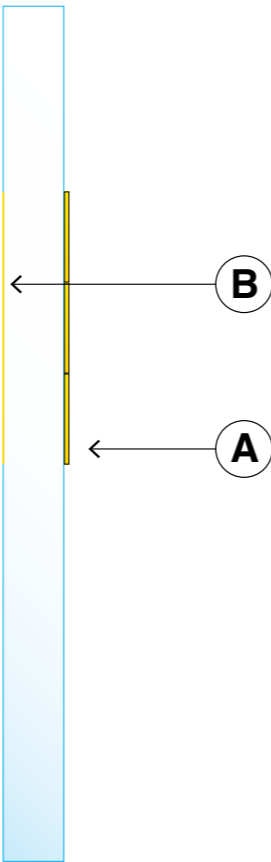

02 Elevation
Glazing-mounted
Scale 1:5

Construction Details

- A Signform**
3mm aluminium panel finished in C1, adhesive fixed direct to surface.
- B Self-adhesive film**
When sign is mounted to glazing, self-adhesive film fixed direct to internal or reverse surface to hide adhesive (digitally printed to match C1).

Wall Mounted Signforms: Notice Boards



01 Plan
Scale 1:10

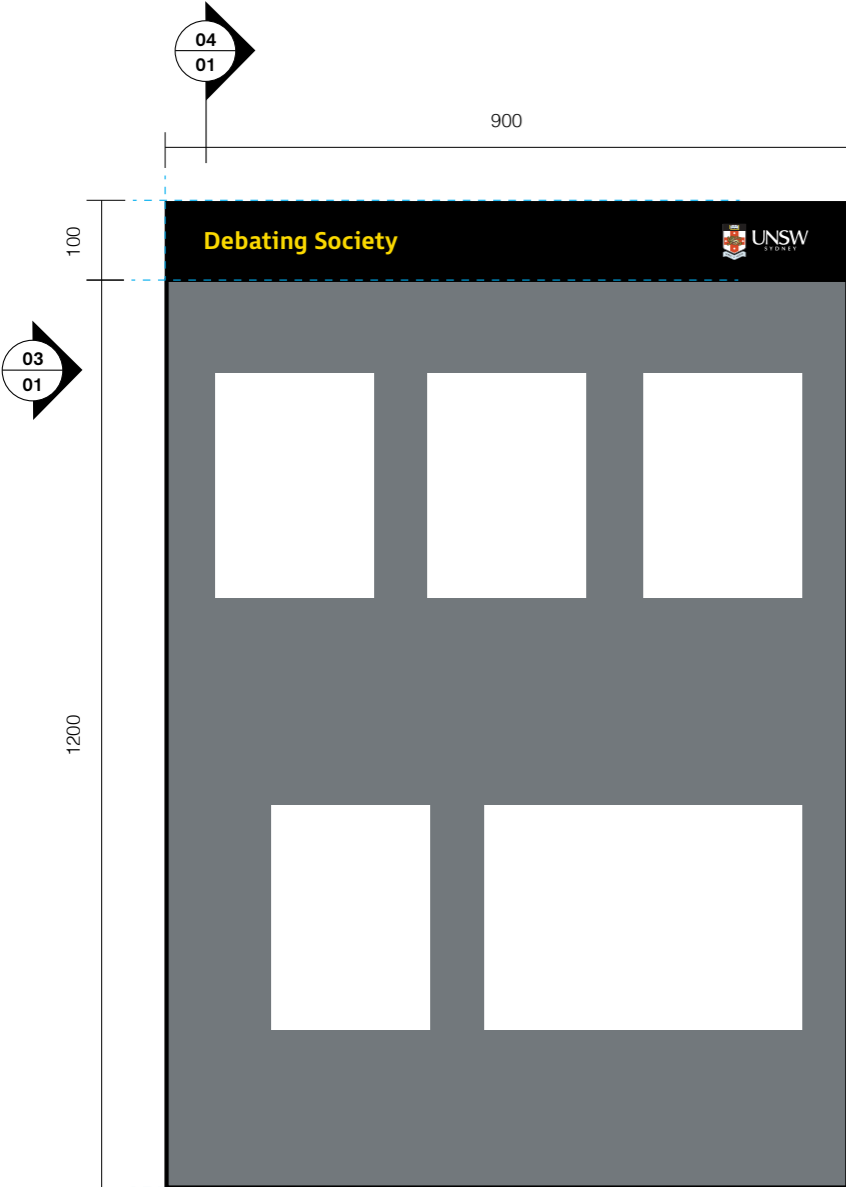

02 Elevation
Scale 1:10



03 Elevation
Scale 1:10

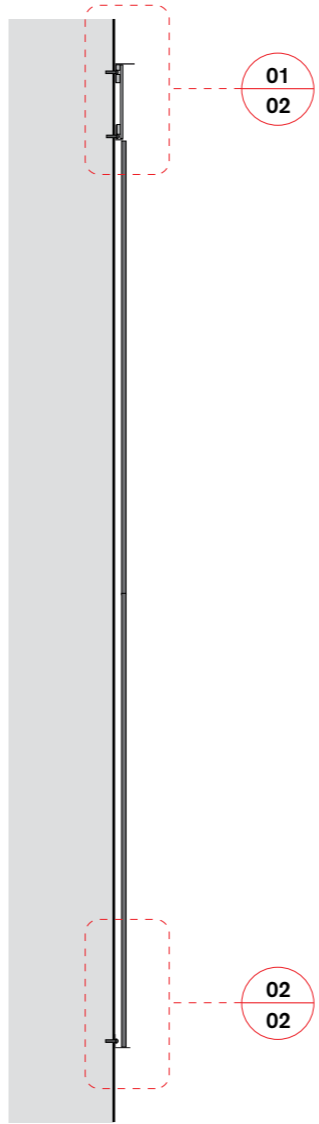

04 Section
Scale 1:10

Internal Noticeboards

The internal noticeboards make use of an off-the-shelf pin-board system that is customised with UNSW branding to suit the rest of the signage system.

Wall Mounted Signforms: Notice Boards

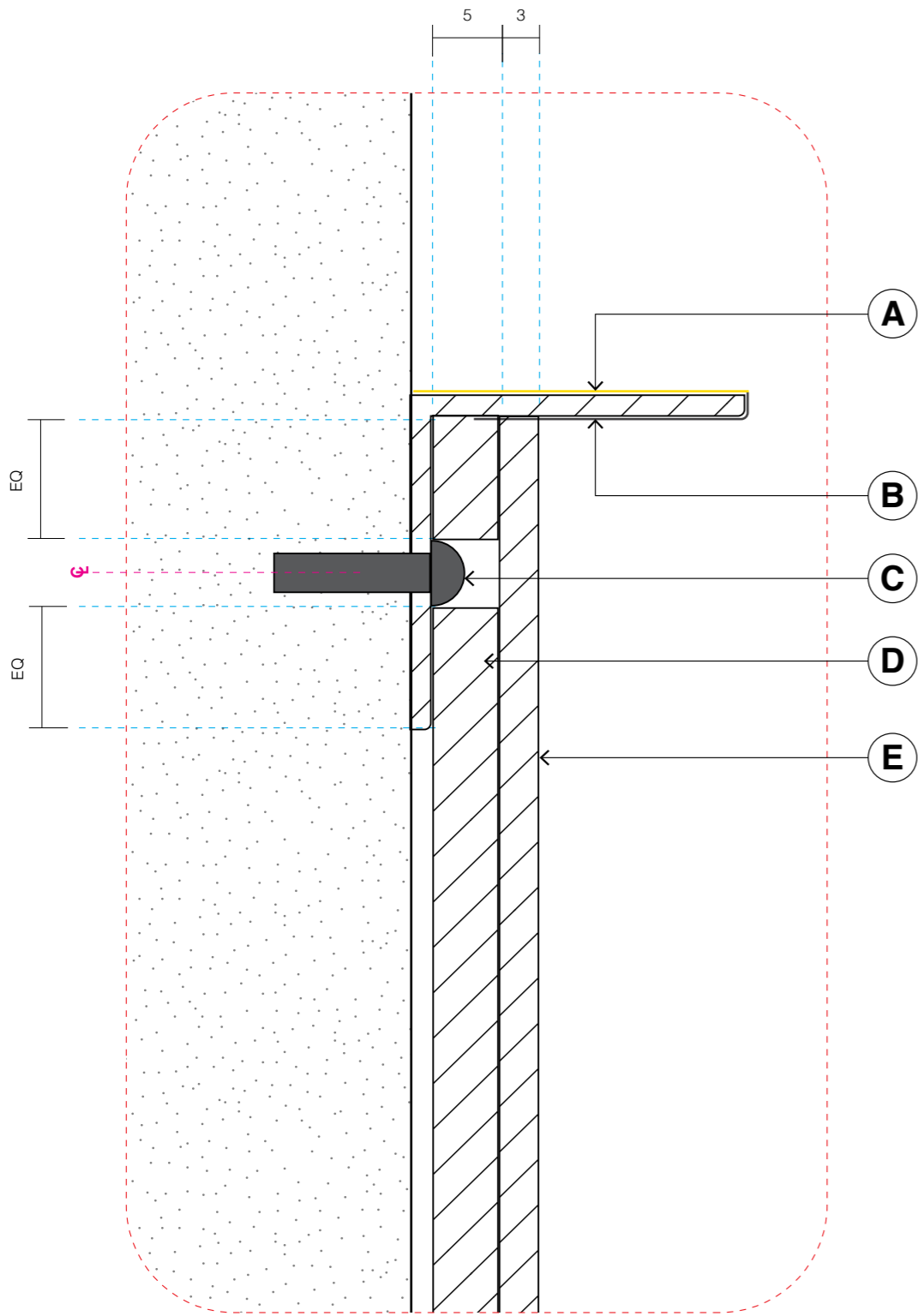

01 Detail
Top edge
Scale 2:1

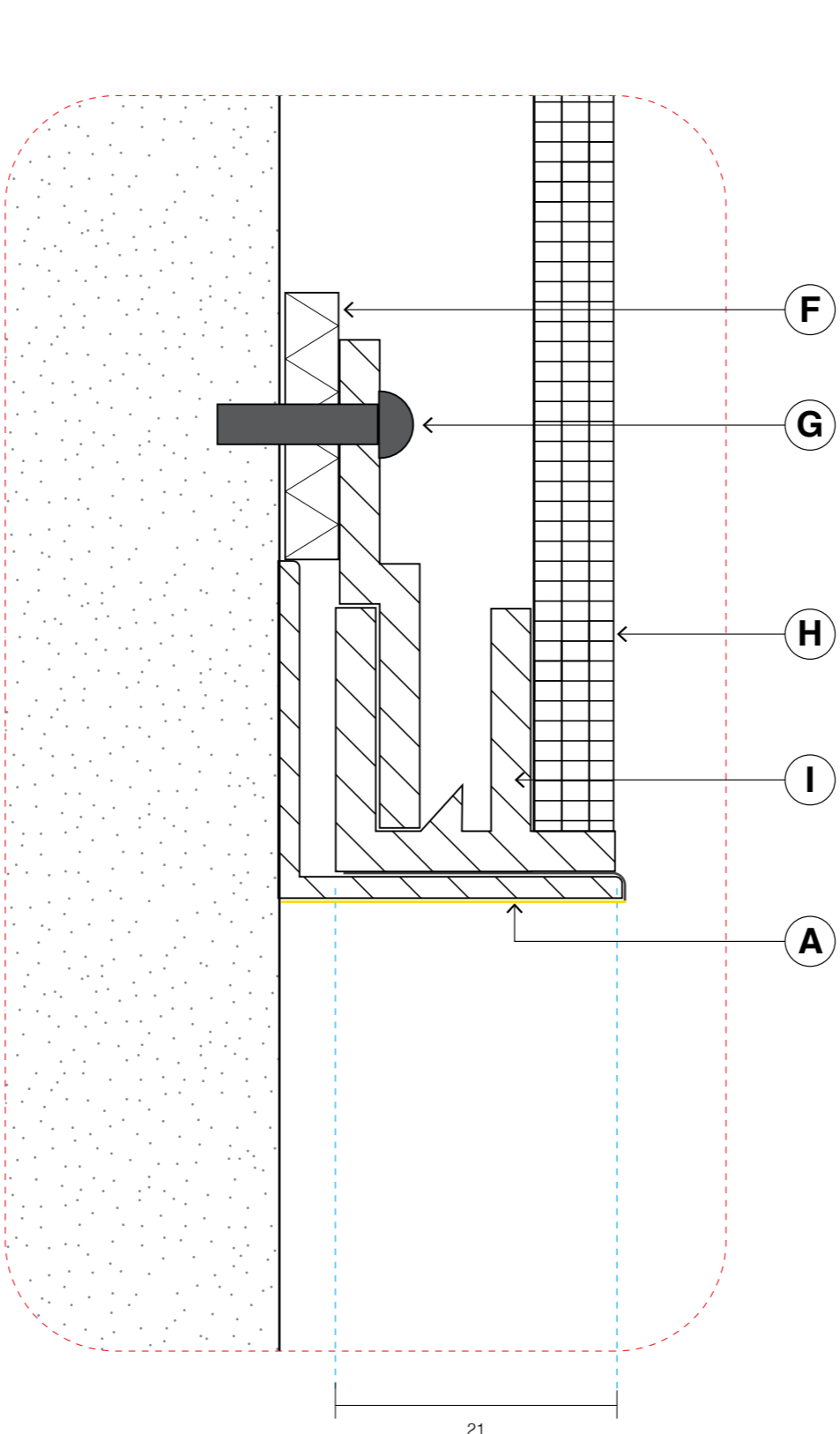

02 Detail
Bottom edge
Scale 2:1

Construction Details

- (A) **Outer Frame**
Noticeboard frame as an aluminium angle with outer face in C1.
- (B) **Inner Frame**
Inner face of frame finished in C2
- (C) **Fixing**
Nylon anchor fixing, contractor to advise fixing method
- (D) **Backing**
5mm thk aluminium backing strip
- (E) **Name and logo panel**
3mm thk aluminium panel finished in C2. Self-adhesive film graphics in V1 and S1 applied on top and finished with protective clear coat
- (F) **Backing**
4mm thk MDF backing
- (G) **Fixing**
Off-the-shelf Vispin Microframe bracket fixing
- (H) **Pin-board surface**
Krommenie backing material in "Poppy Seed"
- (I) **Pin-board display frame**
Off-the-shelf Vispin Microframe display with black powdercoated frame to match C2

Wall Mounted Signforms: Notice Boards



01 Plan
Scale 1:10

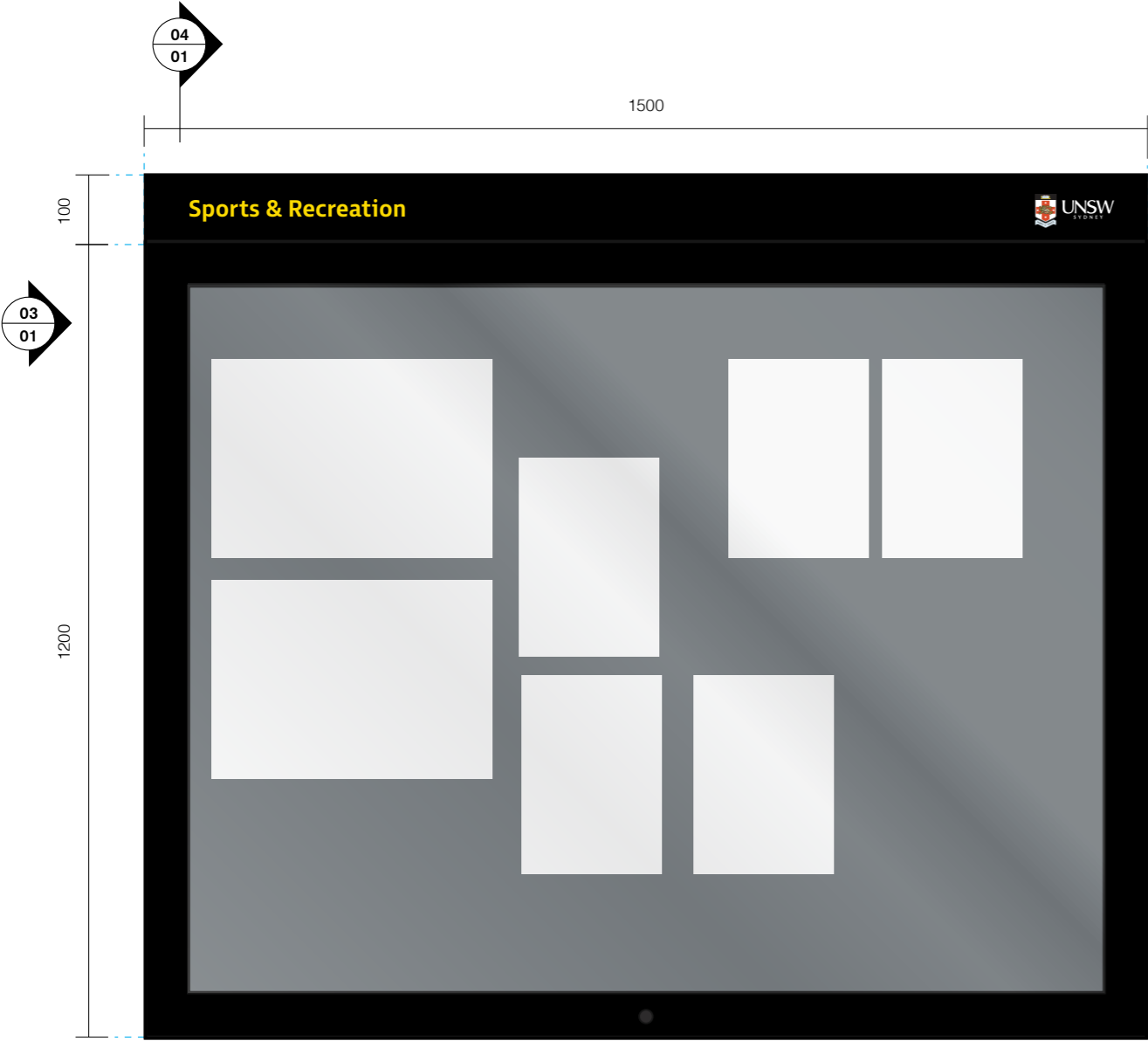

02 Elevation
Scale 1:10

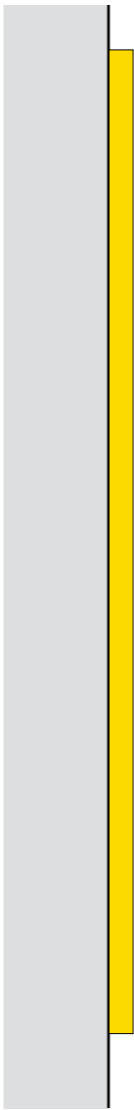

03 Elevation
Scale 1:10

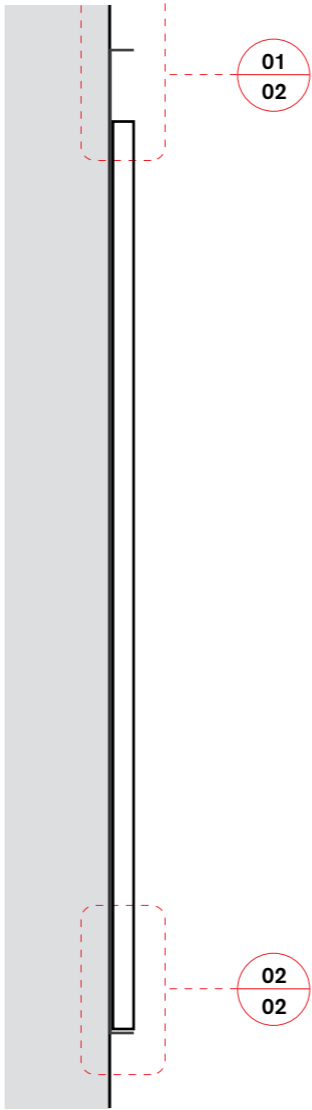

04 Section
Scale 1:10

External Noticeboards

The external noticeboards make use of an off-the-shelf lockable cabinet system that is customised with UNSW branding to suit the rest of the signage system.

Wall Mounted Signforms: Notice Boards

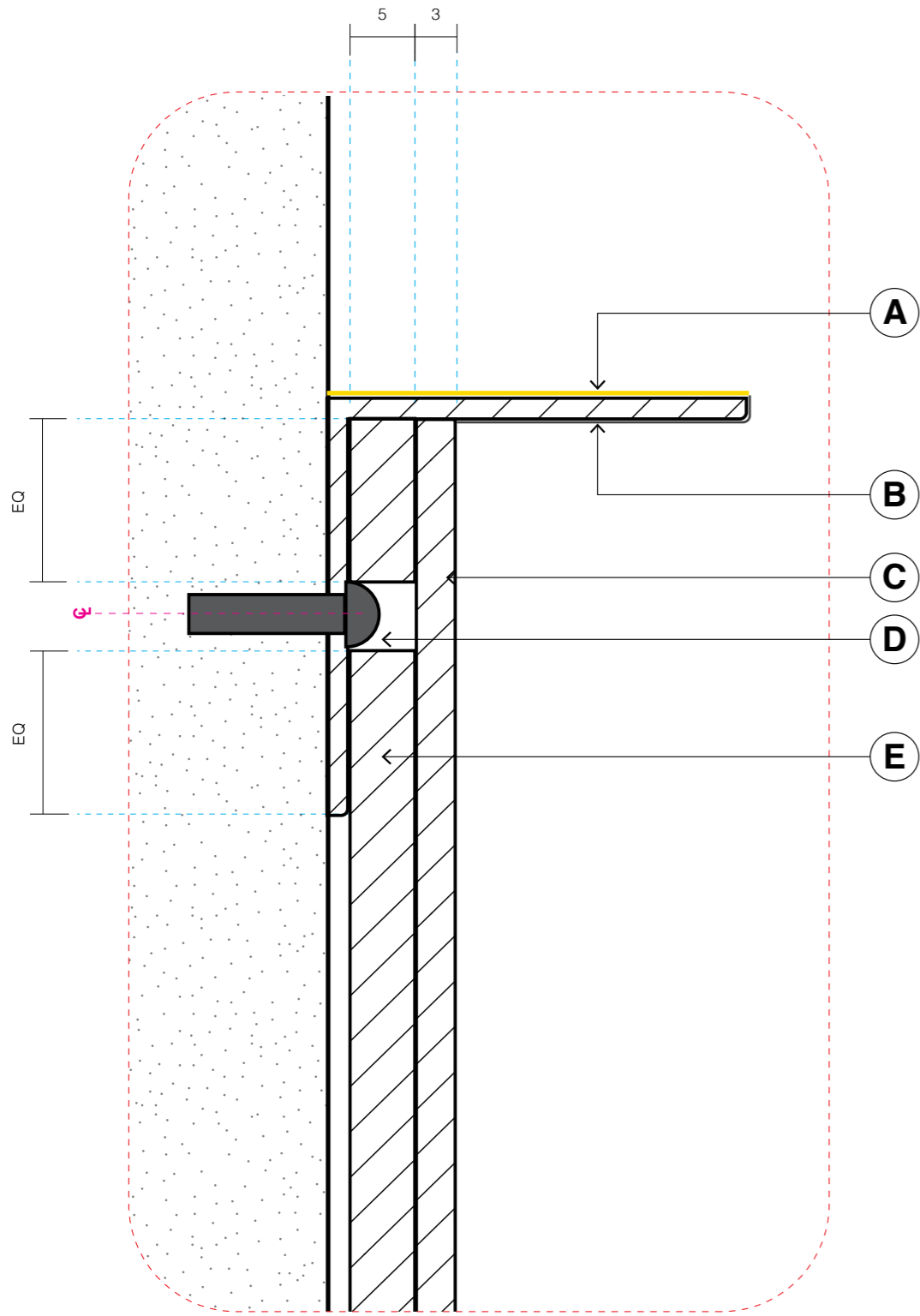

01 Detail
Top edge
 Scale 2:1

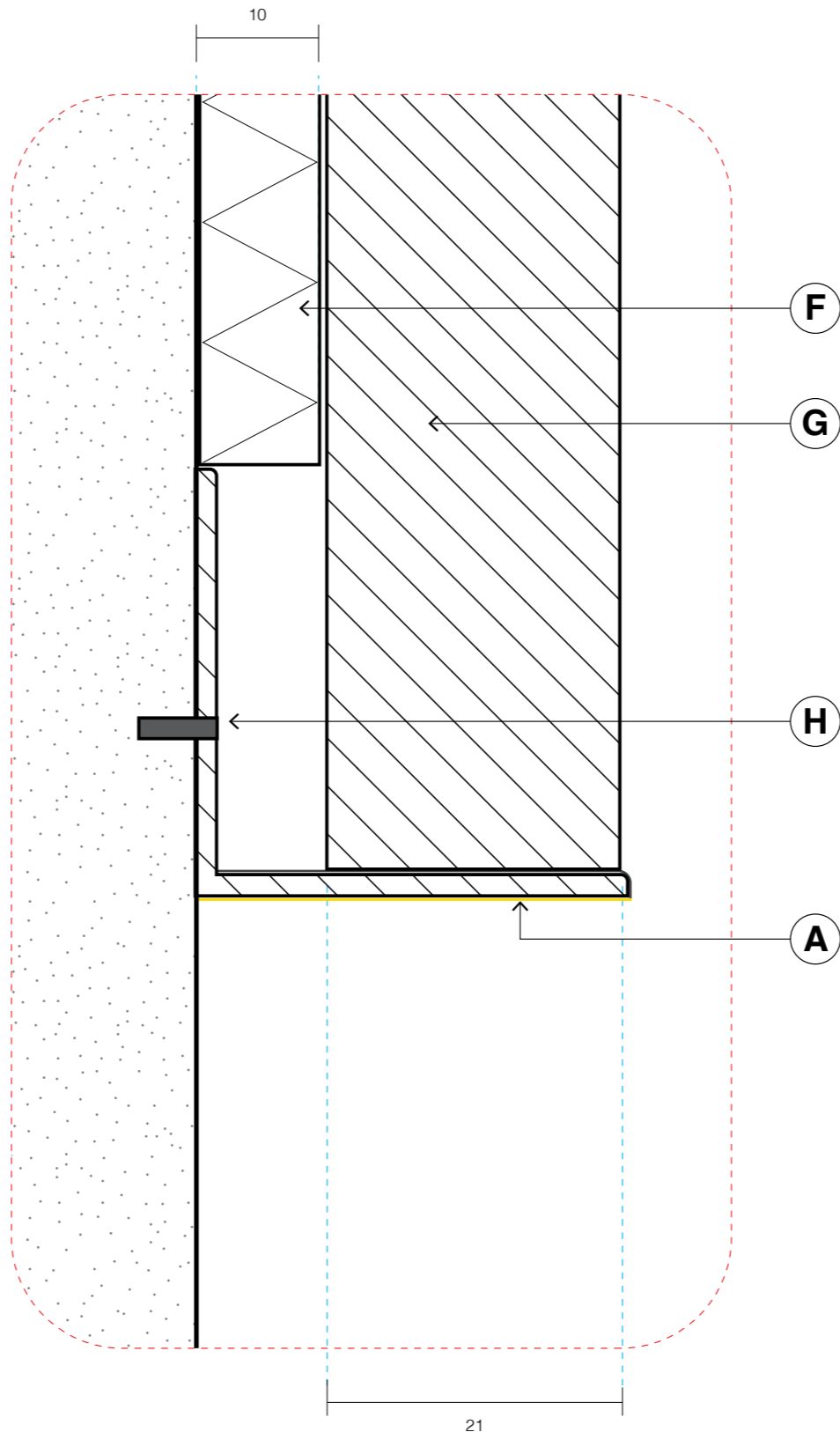

02 Detail
Bottom edge
 Scale 2:1

Construction Details

- (A) Outer Frame**
 Noticeboard frame as an aluminium angle with outer face in C1.
- (B) Inner Frame**
 Inner face of frame finished in C2
- (C) Name and logo panel**
 3mm thk aluminium panel finished in C2. Self-adhesive film graphics in V1 and S1 applied on top and finished with protective clear coat
- (D) Fixing**
 Nylon anchor fixing, contractor to advise fixing method
- (E) Backing**
 5mm thk aluminium backing strip
- (F) Backing**
 10mm thk MDF backing
- (G) Cabinet display frame**
 Off-the-shelf Civiq Flexidisplay Cliplok cabinet with black powdercoated frame to match C2
- (H) Fixing**
 Off-the-shelf Civiq fixing bracket

Direct Applied Graphics: Mask and Spray

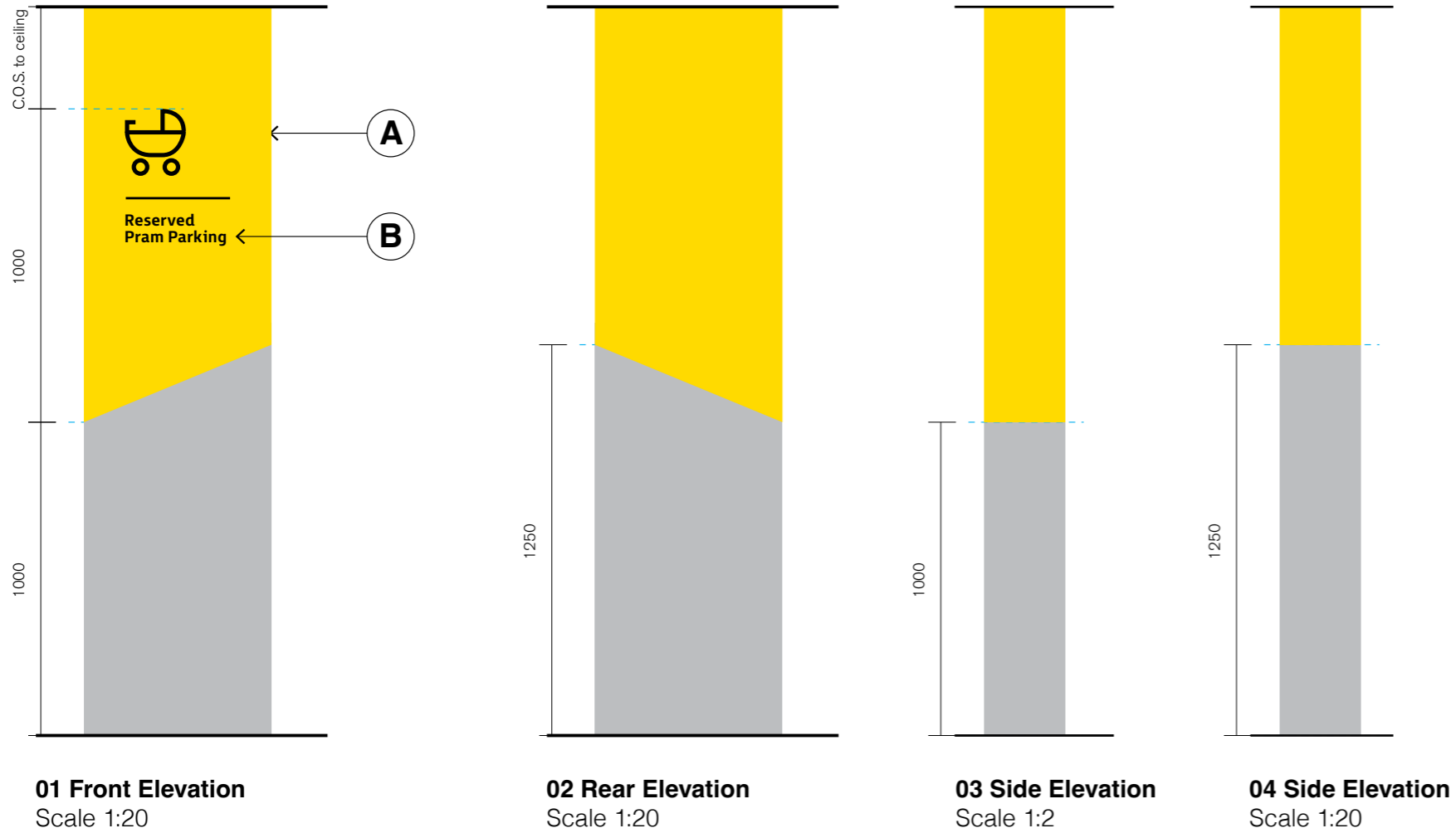

Construction Details

- A Mask and spray**
Matte wall paint P1 applied direct to column, size adjusted depending on column height and width as per contractor measurements.
- B Mask and spray**
Matte wall paint P2/P3 applied direct to column. Substrate condition/finish will vary between buildings. Determine on site with contractor to ensure clarity of line work and legibility of message.

Off-the-shelf

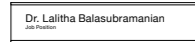

A

Name Plate

To be integrated with ID.20e and ID.20f Room ID Family



B

FlexiDisplay ClipLok

TD.01 and TD.02 Noticeboard External (Large and Small)



C

VisiPin Microframe

TD.03 and TD.04 Noticeboard Internal (Large and Small)

Construction Details

A

50 x 250mm nameplate frame from **Benchmark Engraving:**
http://www.benchmarkengraving.com.au/cotents/en-us/p27_SAE4_wall_door_namebar.html

B

1200 x 2400mm and 1080 x 2100mm noticeboards from **Civiq:**
<https://www.civiq.com.au/product/flexidisplay-cliplok-wall-mounted-premium-notice-board/>

C

600 x 900mm and 1200 x 1500mm pin boards from **Civiq:**
<https://www.civiq.com.au/product/visipin-microframe-pinboard/>

UNSW

For sections 09 - 12, refer to chapter G.2

For sections 13 - 17, refer to chapter G.3

For sections 18 - 23, refer to chapter G.4



UNSW
SYDNEY