



**O-WEEK:
MAKE YOURSELF AT HOME**

University **LAWN PARTY**

WEDNESDAY MARCH 30
Emirates OAKS LADIES DAY
ROYAL RANDWICK

The University Lawn Party will be the hottest place to be this Easter Carnival at Royal Randwick. Emirates Oaks Ladies day on Wednesday, March 30, will come alive on the Leger Lawn. All of Sydney's major Universities are participating in this huge party. It will be a great opportunity to catch a glimpse Australia's greatest thoroughbred action from a private party zone, amongst friends and counterparts.

WHAT'S ON OFFER

All inclusive beverage and entertainment ticket will entitle you to:

- Racecourse admission – \$25 (over 18 year olds)
- All inclusive beverage package (including beer, wine, soft drinks and sparkling)
- Live entertainment all day by

AFTER THE FALL
ROCKET SCIENCE
ELEVEN LIVE

- Food voucher
 - 7 University named marquees
 - Trackside private party zone
 - Competitions and giveaways
 - Private food and betting facilities (food additional charge)
- COST: \$79.95 per person (inc. GST)**

BOOKINGS
www.ajc.com.au



www.ajc.com.au

4 DAYS TO PLAY.
 DAYS TO RECOVER.

BLITZ

BLITZ MAGAZINE

Telephone: 02 9385 7715
Fax: 02 9313 8626
Address: PO Box 173,
Kingsford 2032
Level 1, Blockhouse, Lower Campus
blitz@union.unsw.edu.au
web: www.union.unsw.edu.au

BLITZ ADVERTISING

Advertising Artwork 12 days prior to publication. Bookings 20 days prior to publication. Rates and enquiries should be directed to Charlotte O'Brien on phone: 9385 7331 or email: c.obrien@union.unsw.edu.au.

CONTRIBUTIONS

Letters, articles, photos and other printable matter are welcome. Please contact editor to discuss suitability.

PUBLISHER

Blitz is published each Monday of session by The University of New South Wales Union.

The views expressed herein are not necessarily the views of the Union, unless expressly stated. The Union accepts no responsibility for the accuracy of any of the opinions or information contained in this issue of Blitz. Any complaints should be addressed to the Communications Manager, at PO Box 173, Kingsford 2032.

PRINTING

Printed by Agency, Seven Hills. Rates and enquiries should be directed to 8825 8900.

BLITZ TEAM 2005

Editor: Ben Smyth
Reporters: Rob Gascoigne, Matt Lim, April Smallwood
Designer: Anjali Belani
Communications Manager: Marina Spurgin, 02 9385 7731
Advertising & Sponsorship Coordinator: Charlotte O'Brien
Marketing Manager: Donna Wiemann

O-WEEK TEAM 2005

Co-ordinator: Michael Richardson
Development & Support: Sandra Plummer P
Publicity and Promotions: Jeff Forster
Design: Jinny Skerman 000
Tours and Training: Cam Hollows
Entertainment: Amy Ward
Social Programs: Sophie Harrington
Sponsorship: Will McDougall
The University of New South Wales



EDITOR'S LETTER by Ben Smyth

UNSW. Straight lines and glass. What were they thinking? Modern architecture might be very now, but making a university out of it is a sure way to scare the pants off the new students.

It's not saying that campus architecture is the sole cause of first-year disquiet. In one short period you have become or soon will be legal adults, are expected to magically discover how to work unsupervised and are now free from the tyranny of uniforms. To top it off you've been given access to a bar. You're crazy if your eyes aren't spinning around in your head.

But you know what would be crazier? If you spend three years or more on campus without discovering any interesting people or events. If you spend your time going to class and then going home. If, when years later people ask what you did in your university years, you shrug your shoulders and say "Dunno, I didn't really do anything." That would be nutty.

This is where Blitz comes in. It's our job to keep you informed and entertained every week that you're at uni. We don't pretend to know all the answers (actually, we might). We don't pretend to know what's best for you either (to be honest we'll probably do that too). What we do know, however, is what's going on around here.

There is an awful lot going on in O-Week. So we collaborated with the O-Week team to produce this edition of Blitz (and many thanks for that!) Part one will tell you about the support services, clubs and societies that are provided by the Union and others all year round. Part two, the What's On section, keeps you informed about parties and events organised for O-Week. Finally, our entertainment section includes art, games, and stories.

It might not seem welcoming or comfortable right now, but with time this place will begin to feel like home. If you talk to your friendly Yellow Shirts, read Blitz and find yourself some friends, in no time you'll be putting your feet up on one of the hundreds of modern, pointy objects littered around the uni and wondering what you were so worried about.

Welcome 5

Clubs & Societies 6

U-SPACE 7

SUPPORT SERVICES 8

How to... 11

The Roundhouse 12

Kid Kenobi 13

Eskimo Joe 14

WHAT'S ON 15

VISUAL BLITZ 21

Student stereotypes 22

Travel 24

Tips from a Veteran 25

SNAKES & LADDERS 26

Classifieds 29

VOX POPS 30

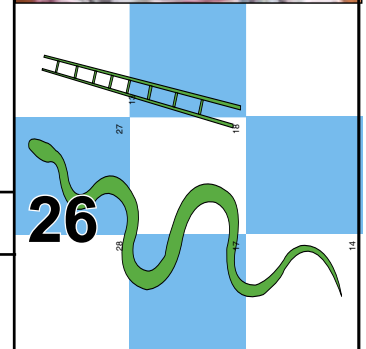
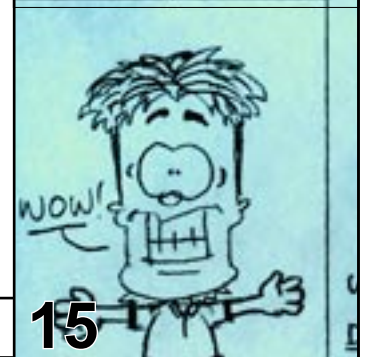
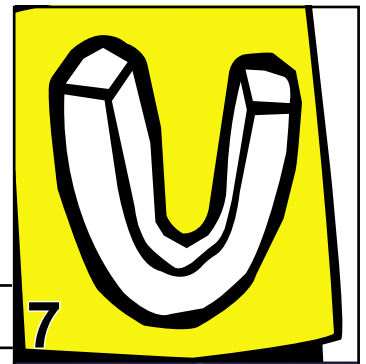



GILIGAN'S ISLAND PARTY

THURSDAY, MARCH 3, 2005

FUNKTRUST,

MATT ROBERTS, MEEM DJ Set,

AND DEEPCHILD DJ Set

FREE FOR UNSW STUDENTS OTHER STUDENTS \$5/

ALL OTHERS \$10 • DOORS OPEN 8PM

HAPPY HOUR 8PM • THE ROUNDHOUSE, UNSW

The University of New South Wales
UNION



PRESIDENT'S WELCOME

By David Hume



When I first started uni, I went to O-Week and was introduced to another first-year by a Yellow Shirt. The Yellow Shirt told me that if I remembered one thing throughout my time at university, it was that this first-year could be the person that I need to prepare the perfect exam notes with, that I need to flatmate with when I go on exchange, or the person I take to a party at the Roundhouse. Five years later I have never regretted meeting that person - he became one of my closest friends.

The Yellow Shirts are just one of many services and programs provided by your Union. The Union's mission is to create a community at UNSW and to ensure that the campus is not just somewhere you visit to get a piece of paper in three years time. As students of UNSW, you are all automatically Union members.

The Union creates a community by providing you with a wide range of services, and programs tailored to suit your passion. Most of the food and retail outlets on campus are run by the Union. They offer cheap food and drinks, or just a comfortable place to sit down and chat.

The Union runs a number of volunteering programs, employment programs tailored for students, such as R.S.A certification, as well as courses in skills like dancing, film-making or photography. They are educational and a great opportunity to meet new friends.

The Union provides a series of publications: The weekly Blitz magazine tells you what's on and where it's on on campus; you can record your busy social calendar in the Union student diary; the Unsweetened literary journal provides a forum for more creative students to show off; and the International Cookbook publishes the best of your submitted recipes.

This, and a whole lot more, is provided free or really cheap to you by your Union. University life has so much to offer, regardless of whether you're interested in meeting inspiring people, learning skills or just getting a job. The next few years will be the greatest experience of your life and I urge you to make the most of them.

If you want any more information about the Union and campus life, call me (Dave) on 9385 7724, email me at u.president@union.unsw.edu.au, or just drop by the Blockhouse.

O-WEEK COORDINATOR'S WELCOME

By Michael Richardson



Welcome to UNSW and to Orientation Week! O-Week is an entire week of the UNSW year just for you – it's all about helping students new to our university discover the campus, its community and the opportunities it offers to make the most out of their degree. From campus tours to faculty welcomes, BBQs to jelly wrestling, the comedic genius of Wil Anderson to the musical brilliance of Eskimo Joe, O-Week is a party with a purpose. It exists to give you the best opportunity to hit the ground running when classes start next week, to be an active participant in the UNSW community and to start your uni career with confidence and energy.

If you really want to get the most out of your O-Week you should get into it and get involved. There's enough going on around campus to keep anyone entertained, along with over a hundred dedicated and enthusiastic Yellow Shirt volunteers to help make your week great; you'll recognise them by the yellow shirts they wear. Wander up and chat – Yellow Shirts have a wealth of campus knowledge and are more than happy to help you find what you need. Take the time to meet other new students, through activities around campus or just by introducing yourself. Most people at O-Week are new to UNSW like you, so you won't regret taking the risk and saying g'day. Take a campus tour, check out the clubs on display and come along to the awesome nighttime events.

UNSW is a vibrant and friendly community, not just a place to come and study for a few years. Discover it during O-Week and you won't regret any lost opportunities at university. It's a community that has opened up so many possibilities for me and all the Yellow Shirt volunteers. I hope that we can give you the same good times, great experiences and life-long friends that university has given us.

Make your O-Week a week, not just a day. There's plenty to see and do, dozens of new friends to be made and hundreds of memories to create. Get yourself comfortable at UNSW. Put your feet up and make yourself at home.

I'll see you at the Roundhouse!



MAKE YOURSELF AT HOME

CLUBS & SOCIETIES AT UNSW

By Matthew Lim

You've just been thrown into a mix of over 40,000 students at UNSW. Feeling the need to belong?

Why not join a club or society? They're a great way to find a network of new friends, participate in social events and be involved with something you are passionate about. With around 250 clubs and societies running at UNSW, you're sure to find one that suits your innermost desires, however strange they may be.

At your selection are theatrical societies, faculty societies, sports clubs, various musical societies and other more interestingly titled examples such as ChocSoc, BeardSoc or SpockSoc. Your best opportunity to see what is available will be during O-Week, when many of the clubs and societies will be set up in stalls along the campus walkways.

Clubs and Societies On Campus (CASOC) is the governing body for clubs and societies and is part of the Student Guild. Matthew Lee is the CASOC Director for 2005. He says the biggest clubs are the 'constituent' clubs that are tied to a faculty - if you are a student of that school you are automatically a member.

The rest of the clubs, which form a majority, cover a broad spectrum of culture, sport, religion, music, theatre and special

interests. The more active popular clubs include cultural clubs such as the Chinese Students' Association (CSA), the Hong Kong Students' Society (HKSS), the Taiwanese Student Association (TSA) and dance clubs such as D²MG and the Salsa Club.

A good club is one that gives back to their members. "It's great that clubs are [financially] sustainable in themselves," says Matthew, "but it is important that they also provide fun and services for their club members."

If you can't find anything to join (how picky can you be?), there's always the option of starting up your own club. To affiliate a new club with CASOC you'll need to find fifteen similarly interested people who are UNSW students, hold an Annual General Meeting, elect nine executives and then submit your request to CASOC. If you're successful then all you need to do is turn up to the fortnightly CASOC meetings and you are officially a club (or society).

The old adage that you only get what you put in holds true; you sure get a lot more out of University life when you get involved in the various clubs and societies, sports, or volunteer programs that are available.

FREE to UNSW Students

2005 Student Diary + NEW  Discount Card

for members only

Save \$500+

with vouchers from McDonalds, Pappa Hut, Dominos, Pretzel World, Wendy's, Goldpin Bowling, Manly Twin Cinemas and more!

Repeat discounts - 5% to 50% - off restaurant dining takeaways, tickets to major attractions, car rentals, books, hotel and motel accommodation, and all sorts of bargains at retail and online stores nationally.

Take 2 easy steps and save heaps:

1. Fill in a registration form. Available now at Union Reception, online at www.union.unsw.edu.au and at e-spot in O-Week
2. Take your completed form to e-spot in O-Week and Week 1, or UNSW Union Reception and collect your free Diary and Discount Card

The UNSW Union respects your privacy. We adhere to a Privacy Policy in line with the national privacy principles. If you would like a copy of our privacy statement and/or policy, please refer to www.union.unsw.edu.au or call 9385 7700.

IT'S ALL ABOUT U

By April Smallwood

U-Space is where it all happens. Home of the UNSW Union's Student Development Branch, U-Space runs many courses and various programs while offering numerous volunteering positions. When getting involved with U-Space, students are given the chance to discover new social and employment skills by interacting with fellow participants. Many students completing U-Space's programs have described them to be fun, useful and very rewarding.

I had a sit down with the three U-space coordinators and asked them what they're all about. Due to the casual and conversation-like nature of our chat, you may be curious as to just who is answering each question but hey, I often wondered that myself.

So what is it you do? We are from the student development department of the Union. Each one of us holds a different role. Simon Jobson is in charge of Culture and Diversity. Andrew Johnston's department is Arts and Volunteering and Steve Gore organises the Employability and Leadership component. All in all, we're out to produce confident people who can have fun while they're at uni.

What can students do if they're interested in U-Space? We have opportunities for volunteer students and also for student coordinators who are paid for working about 15 hours a week. These students are taught to run the program and we help them out when they need a hand.

What kind of rewards do the programs provide? Each program is different, offering different opportunities to the students. Our programs help students develop skills, for work and personal development. We help enrich the student experience so that life skills and workforce skills are broadened. The other big thing is to just have fun.

Do students often return wanting more? People who start out in one area of U-Space tend to continue getting more involved. Andrew started out as a yellow shirt, got interested in the Union, kept coming back to help out here and there and eventually got a job out of it, which is great.

What about students not looking to volunteer? We try to offer opportunities for everyone; it's not just about volunteering. We also have events throughout the year where students can just come along to get involved in the fun side of things. This year we have a literary program called 'Lit Up' starting in the form of a website which is to be launched in Week 3. Here, students are free to submit writings for everyone to read and gain feedback on.

What costs are involved? The workshops are excellent value. Most of the ones run by Andrew are free and Steve's Responsible Service of Alcohol (RSA), barista course and others are significantly reduced.

So when you arrive to work in the morning are you happy to be here? Yeah yeah - its the best job in the world. It's good to see new people coming in and also to have someone come in at the end of the year and then go "That was awesome, thanks. I got this out of it or that out of it." We are more than open to program ideas or suggestions from students. We wanna make students lives better so if there's anything they want, we're here to try and make that happen.

How will students find out more about U-Space? O-Week is a really big time for us; we try to grab as much attention as possible to grab as many volunteers as possible. Also during the year we attract more students through Blitz and various marketing ventures.

OUTBACK ASSIST : A NEW PROGRAM FOR 2005

What: To gather about 15 students and fly to the Santa Theresa Aboriginal community, 70kms South East of Alice Springs in the Northern Territory

When: After exams during mid session break.

Why: To work with the community for a week or ten days, help out at the local school as classroom aides or help construct an obstacle course for the local kids to play in.

How: There will be fundraising activities to generate travelling costs.

For more information, e-mail:

outbackassist@union.unsw.edu.au or drop into the offices.

U-Space is located in the Blockhouse (just inside the Anzac Parade entrance) where you can drop by any time to find out more about how to get involved.



As a student your first day, week, or even semester at university can be a daunting experience. Hell, even some third-years can still feel overwhelmed. Rest assured, though; UNSW doesn't throw you in the deep end and then forget about you. Here is a summary of services available to students and a brief explanation on what they do.

The Student Guild (www.studentguild.unsw.edu.au)

The Student Guild was established to be the peak representative body for all students on campus. Student welfare services offered include: free legal advice; HECS, HELP, Youth Allowance and Austudy advice; subsidised childcare; The Women's Room; and Queer Space.

The Guild Office is located on the first floor of the Quadrangle building. All students are automatically members and thus entitled to benefits and support.

Contact (www.contact.unsw.edu.au)

CONTACT is an information and referral service sponsored by the University, the Student Guild and the University Union. If you need to know something about uni, or in fact anything, CONTACT is a good place to start. CONTACT is run by student volunteers. Everyone who works here will know just how to help you and if they don't know the answer, they will know who will! Located on Level 2 of the East Wing of the Quad building, the office is located about halfway down the Basser Steps - follow the signs or ask your yellow shirt tour guide. Open 10am - 4pm, Monday - Friday.

The Learning Centre (www.lc.unsw.edu.au)

You'll soon be informed that writing at university is miles apart from the drivel you produced in high school. One word will be repeated to you ad nauseam: Plagiarism. It's absolutely frowned upon for obvious reasons, and for you fresh-out-of-high schoolers it is so last year. This is where The Learning Centre (located inside the main entrance to the Library - no excuses for not knowing where it is!) comes in. They provide several services that can be of great assistance to those lost for... what's that word again...? Learning Centre services include: Academic Skills Workshops on

topics such as reading and note taking, essay and report writing, critical thinking, and seminar presentations; Academic English Workshops on grammar, academic vocabulary, pronunciation, conversation, listening skills and academic writing; and individual consultations by appointment with a Writing Assistant who can help you improve your academic writing and give you feedback on your work.

The Learning Centre also provides handouts on the above topics and many more. They are available free of charge from The Learning Centre and can be downloaded from its web site.

UNSW Counselling Service and COMPASS Programs (www.counselling.unsw.edu.au)

COMPASS is the name given to the programs that the UNSW Counselling Service provides: Counselling, Orientation, Motivational support, Personal skills development, Advisory services for staff, Seminars and workshops and Self Help resources.

COMPASS offers individual counselling, workshops and seminars and self help material. Just some of the things they can help with include: procrastination; relationships; balancing work, study and life; program indecision; and general uneasiness or worries.

To see a COMPASS counsellor, students can drop in during weekdays between 11-12:30pm or schedule an appointment on 9385 5418. They are located in Level 2 of the Quadrangle building.

UNSW Health & Dental Service

The University Health Service provides comprehensive and high quality health care to the campus community at UNSW. These services include general practice services, women's health and antenatal care, traveller's health advice and vaccinations, men's health and psychiatric services.

Appointments are essential and can be made in person or by telephone. The duration of a standard consultation is between 10-15 minutes. If required you can request a longer consultation when you are making your appointment.

Medicare cardholders are bulk billed, meaning there is no additional cost to the patient. For non-medicare patients, payment is required at the time of consultation.

Students should bring their Medicare card or Medicare number and expiry date. It is recommended that all international students be covered by health insurance; you will receive a full refund on presentation of your receipt to insurer.

The University Health Services are located on the Ground floor of the Quadrangle Building. They can be contacted by telephone on 9385 5425.



IN THE DEEP END ?

By Matthew Lim

Kingsford Legal Centre

The Kingsford Legal Centre (KLC) was established in 1982 and is a community legal centre and a teaching facility of The University of New South Wales. Many final year Law students go through the KLC to gain industry experience that also counts toward academic credit.

According to Karen Lam, law clerk at the KLC says the centre "...offers free and confidential legal advice, referrals and ongoing assistance to people who live, work or study in the local government areas of Botany Bay City Council and Randwick City Council. We give free legal advice on most legal issues. We also help people throughout New South Wales on discrimination cases."

This means that services are provided to staff and students of UNSW, provided that the advice is not against UNSW.

The KLC is located at 11 Rainbow Street, Kingsford and can be contacted via telephone on 9398 6366.

UNSW Careers & Employment (www.careers.unsw.edu.au)

Careers and Employment assists students with the development of career management skills. The most prominent part of their service is their website (listed above), which is split into 3 main sections: Careers Education; Student Employment; and Employer Services. The Jobs Online link is a regularly updated classifieds section dedicated to listing jobs suited to UNSW students.

Other useful services are the weekly Workshops and Individual Assistance. Students can register, then rock up to employment seminars (usually lasting two hours) held on campus or they can make an appointment to see the staff at the centre for personal help with general careers advice, such as how to write a resume or the best career options for individuals.

International Student Services (www.international.unsw.edu.au/iss)

Studying at a local university in a foreign country can be intimidating, and it's important to be able to adjust to the different lifestyle that comes with living and studying in Australia. International Student Services (ISS) are dedicated to helping international students feel settle into UNSW and indeed Sydney as a whole. The advisers at ISS are experienced with helping students and have special knowledge of the issues that may affect international students as they have been international students themselves!

Throughout the year ISS continue to provide ongoing support and services for all international students through individual assistance, regular social activities and day trips and holidays.

ISS are located on Level 1 of Red Centre. Their contact phone number is 9385 5333.

Information Communications Technology Assistance and Training (www.ictassist.unsw.edu.au/sessions.html)

ICT Assist offer several free drop-in courses on computer-related topics like word processing, spreadsheets, WebCT, and searching for information more effectively on the World Wide Web. They are located on Level 2 of the Library, near the public lifts and photocopiers.

Equity & Diversity (www.equity.unsw.edu.au)

The Equity and Diversity Unit provides services to students and staff regarding anti-discrimination legislation, policies and practices grievance handling procedures and disability services. They can be found in Room 922, Level 9 of the Applied Sciences Building or contacted by telephone on 9385 4734.

UNSW Security (www.security.unsw.edu.au)

UNSW Security Services offer a range of services. Of particular importance to new students is E-Spot, which handles UNSW ID cards, travel concessions and lost property, and the Unibeat Program, the Crime Prevention arm of Security Services, which offers victim support and a free Night-time shuttle bus around the Kensington Campus area. There is also a COFA Shuttle Bus service provided during the day in-session. UNSW Security and E-Spot can be found on the Basement Level of the Red Centre or contacted by phone on 9385 6666.

THE PROPHECY CODE
BIBLE SECRETS UNLOCKED!

BEGINS 2005 02 APRIL VENUE For more info www.0300.org

THE UNIVERSITY OF NEW SOUTH WALES
Bldg, B11a Room 101
(Lower Campus, near Gate 2)

Hosted By 3am
Telephone 0403 173 629
email: enquiries@0300.org

AMAZING FACTS
An Amazing Facts Down-Link Satellite Event

**Speaker and Author
Doug Batchelor**

is known and loved by millions for his engaging style and clear teaching of Bible prophecy. Through the international Amazing Facts radio and TV programs Pastor Batchelor has helped countless people around the world understand the Bible for themselves.

LEARN HOW PROPHETIC SYMBOLS REVEAL THE FUTURE!

UNSW Sports Association

Lunchtime Sports

Basketball, Netball, Oztag,
Outdoor Soccer, Indoor Soccer,
Touch, Ultimate Frisbee, Volleyball



Sporting Clubs

Over 40 Sporting
& Recreation clubs

Recreation Courses

American Cheerleading, Aussie Rules, Aikido, Archery,
Badminton, Ballroom Dancing, Basketball, Bellydance, Boot Camp,
Capoeria, Canyoning, Combo Dance, City to Surf, Energy Yoga,
Farm Stay, First Aid, Fishing, Fencing, Golf, Gymnastics, Hang
Gliding, Horseriding, Inline Hockey, Inline Skating, Judo,
Judo for Women, Jazz Dance, Kung Fu, Kendo, Krav Maga, Latin
Dance, Lawn Bowls, Paintball, Pilates, Rockclimbing, Rowing,
Sailing, SCUBA, Squash, Street Funk, Surfing, Surf Paddling,
Sword Techniques, Skydiving, Tai Chi, TaeKwonDo, Table Tennis,
Tennis, Triathlon, Volleyball, Windsurfing, Waterski &
Wakeboard and Yoga

Sam Cracknell Pavilion

(on University Walk near tennis courts)

www.sport.unsw.edu.au

HOW TO...

...TREAD WATER WITHOUT USING YOUR HANDS

1. Float in the water with your back straight and vertical, your thighs horizontal and your lower legs vertical – like you are sitting in a chair. Your legs should be apart and perpendicular to each other.
2. Keeping your body and your upper legs still, rotate your feet in circles – your left foot moving clockwise and your right foot moving anticlockwise.
3. Stabilise yourself by paddling with your hands. With practice you will not have to use your hands at all.

This technique is called (for obvious reasons) the eggbeater and it is useful for more than taking a floating coffee break – It is one of the fundamental skills of water polo.

Like an aquatic version of soccer, water polo is an athletic sport played by two teams who score points by passing an inflatable ball into goals at opposite sides of the field. It has been an Olympic sport since 1900.

Players must be able to perform the eggbeater while catching and throwing a ball one-handed, as well as swim for the duration of a match. A goalkeeper like Lea (pictured) must also be able to lift the top half of their body out of the water to block incoming shots.

Interested?

The UNSW Water Polo Club is the third largest in Australia, having around 250 active members. It has a long history of competitive success, male and female, but it also caters for social players. Beginner's training covers the basic skills of water polo, such as throwing and catching with one hand, as well as the eggbeater. You must already be able to swim.

Training for beginners is held at the UNSW Unigym Pool. Women's sessions are on Thursdays from 7-9pm, men's sessions are on Mondays from 8-9pm. Bring some swimmers and a towel. For more information visit the UNSW Water Polo Club website on www.waterpolo.unsw.edu

ABOUT THE ROUNDHOUSE



By Darren Ong

You're a university student now. Congratulations. You've been through years of blood, sweat, and tears to get to where you are today and the only thing you can think about right now... is getting your assessments in on time or, getting drunk and partying.

Okay, now that we've separated the socialites from the scholars, here's the lowdown. Socialising and scholarly pursuit are often best enjoyed together. Remember balance is the key.

The Roundhouse is located on lower campus. It's where you'll find venues and services like the UniBar, Beams Club Bar, beergardens, Ticketek, arcade games (including Dance Dance revolution; yeah, sure you've never played it, Fred Astaire) and numerous food outlets.

The Roundhouse is also the biggest entertainment venue on campus and has seen nice folks such as Koolism, TZU,

Funktrust, 28 Days, PNAU, James De La Cruz and Yoshi all come in and do their thang in 2004. For those with more exotic tastes, some of the international touring acts included Unwritten Law, Sum 41, AFI, and Dashboard Confessional.

If you're the type who would probably receive a Degree with honours in procrastination (it's a 27 year course - full-time), there are also free movies, trivia nights, pool comps, bands and many other ways to distract you. Make sure you check out the Blitz What's On guide, or the web site, www.unswroundhouse.com, to keep up to date with the who, what, where and when.

Now if you're still reading, great, thanks very much, appreciate the support, but reading this is not getting you any closer to the Roundhouse, right? So get going already! Go and get educated!

The Roundhouse and the UNSW Union promote the responsible use of alcohol.

THE FRONTIER TOURING CO AND 2DAYFM PRESENT



WEDNESDAY 2 MARCH
UNSW ROUNDHOUSE
LICENSED/ALL AGES. With special guests **TOWN HALL STEPS**
ONLY AUSTRALIAN HEADLINE SHOW!
TICKETEK 9266 4800 WWW.TICKETEK.COM.AU ROUNDHOUSE 9385 7630
ALSO TOURING WITH GREEN DAY IN MARCH

ON SALE THURS 10 FEB

The album **STILL NOT GETTING ANY** out now thru Warner Music Australia
www.frontiertouring.com www.simpleplan.com



TICKETS ON SALE NOW!

switchfoot
TUESDAY 1st MARCH
UNSW Roundhouse
Licensed All Ages



Tickets on sale from
Ticketek phonecharge 9266 4800 or
www.ticketek.com & Redeye Records

New album **THE BEAUTIFUL LETDOWN**
featuring the singles **MEANT TO LIVE** &
DARE YOU TO MOVE out now thru Sony BMG



John Vanderschueren

KID KENOBI

After being voted Australia's Number One DJ in the Technics Inthemix Top 50 for the past two years running, Kid Kenobi's status as Australia's greatest DJ is certainly beyond question.

Jeff Forrest recently caught up with KK, who was taking some creative time-out before his O-Week gig and jamming with his regular collaborator, MC Shureshock.

Well, to start things off, how did winning the double crown of Australia's Number One DJ two years in a row feel?

Quite an honour, really. I certainly didn't start out DJing ever expecting to be voted number one in Australia, and even once I'd gotten it once, I never expected to get it twice. I've never played to try and get anything like that – I just go out and try and play a good show every gig.

You're pretty much the King of breakbeat in a city that is often called the 'breaks capital of the world'. Why do you think breaks have taken off so much in Sydney? I think a lot of it had to do with the attitude of the DJs and promoters when breaks were first starting out in Sydney. There was a general feeling that we wanted to try and create a scene where people felt welcome, and where there was an entry point. We never wanted people to feel that if they didn't know all of the tracks by name, they couldn't be a part of the scene. Plus, there's a lot of diversity in breaks.

You've been collaborating with MC Shureshock for a number of years now. How did that first come about? I was doing some gigs in Brisbane, which was the first city that I really felt comfortable in outside of Sydney. He was MCing at a night there, and I was impressed by how he was working the crowd. An album called The Stanton Sessions had just come out, and I liked the sound of an MC on that, so I asked him to appear on the first Ministry of Sound: Clubber's Guide to Breaks album. We toured together, promoting that, and it all worked well.

You don't always play with Shureshock – does having an MC at your side mean you play a different set? Musically it's pretty similar, but it can be great having someone who can work with the crowd. Especially when you're playing at events where there is a mixture of live and DJ acts, it adds an extra level of energy to the set.

Is it true that your mum still comes and watches you play?

Yeah, Mum and Dad come along to a lot of the sets. Dad is a drummer from way back. He actually jumped up and played half the set with us at Summafieldaze on the Gold Coast last month, so we had a live percussionist playing along for about half an hour. It was great.

Do you have a favourite set you've played? Or a favourite event you've played at? The Aussie summer festivals are all amazing to play at. Gigs like Field Day and Summafieldaze. There's always so much excitement – everyone treats the events like something to get worked up about and there's more energy than anywhere else. Apart from that, playing at Fabric in London is awesome.

Have there been any tracks that really blew your mind when you first heard them? Tough question. There have been a lot of standout tracks along the way, but no single one. I guess some of the records I listened to when I was a kid did a lot to get me interested in music. Some of my Dad's stuff like Bob Marley, The Wizard of Oz Soundtrack and The Smurfs.

The theme for O-Week this year is 'Make Yourself at Home'. Where do you feel most at home? I'm touring so much that it's hard to think of anywhere that I really feel at home at the moment. I guess I feel most at home in a creative environment, somewhere that I have a space to work and an atmosphere that makes me want to innovate.

You can enjoy the breakbeat stylings of Kid Kenobi and MC Shureshock at the O-Week Housewarming Party on the Thursday night of O-Week. Doors at the Roundhouse open at 8pm and entry is free for UNSW Students.



NOT YOUR AVERAGE JOE

Eskimo Joe are possibly Australia's hottest rock export at the moment, with their song, From the Sea ranking a respectable third in Triple J's 2004 Hottest 100 and the huge success of their recent album, A Song is a City. Joel Quartermain from the Joe's chatted with Amy Ward about growing up, playing music, and the university experience.

Amy - It was a big win for you guys in the Hottest 100. How'd that feel? Joel - You never expect something like that. That was all announced on the day of the Sydney Big Day Out, so it was pretty hectic. We got stupendously drunk in Sydney that day.

What's it like doing a massive tour like the Big Day Out? Do you get much of a chance to check out the other acts? I've been a bit lazy, actually. The Gold Coast gig was so hot that we just sat inside with the aircon all day, then at the Sydney gig we were doing interviews all day. I went out to check out The Hives and The Streets in Sydney, who were both good. And we try and always catch Little Birdy as they're our mates from Perth.

The musical direction of the band has really developed over the years, from a fun punk sounding group with tracks like Sweater to a bigger, more melodic kind of rock. Do you think it was a conscious move?

It's been both a deliberate and a natural progression, and you know, as you get older your musical tastes change. We sat down consciously before [our debut album] *Girl* and looked at where the band was going musically and the musical change has put us in an open playing field where we can do what we want. With the earlier EPs that had a punkier feel, we were joking around. They were basically us having a laugh and we couldn't believe it was on the radio. But the Sweater type stuff doesn't last long, and we wanted albums – they're what you're remembered by, and they're what you can show your kids.

So how does the songwriting process work for Eskimo Joe?

It's collaborative. The songwriting is our favourite part of being a band. We love touring but that doesn't have the same creative rush of taking blank paper into a studio and coming out with songs. We play to the strengths of each member. I was watching a Brian Eno documentary recently from 1995/96 with U2 and his advice to them was that a band is more than the sum of its parts, which really rang true. We usually work by arranging it together and then taking the demo to the studio and layering it up from scratch, which takes about three days for each song on that bit. We like to go into a big expensive studio ready to go. It's the best fun making records. We usually can't wait to make another one. People expect us to progress from the last stuff, and that's what we want too.

You guys are playing a couple of O-Week gigs this year. Was uni a big time for you? I think it's true about uni being the best time of your life – it's the first time you feel really independent, and everything's exciting. I went to the University of Western Australia in Perth and did Environmental Science for a year, but I got bored quickly and changed to commerce and did marketing for a while. I had one year to go when we formed the band and so I left. My parents didn't really agree with that, but the best thing about the ARIAS last year where we won a producing award and played live was that they were ok about the whole band thing after that.

What's next for the Joe? A new album? Touring overseas maybe?

We're fielding interest from overseas labels right now. We might have to spend a bit of time in the U.S. to try and build our name over there. In the meantime we've got to get cracking on some new songs!

Eskimo Joe are headlining the O-Week Final Concert on Friday, 25 February at the Roundhouse, supported by The redsunband and The Outfit. Tickets are just \$10 for UNSW students and are available on campus throughout O-Week.



COORDINATOR'S O-WEEK HIGHLIGHTS

By Michael Richardson

TOURS – MONDAY TO THURSDAY, 2PM – 4PM

These aren't compulsory but they should be. O-Week tours are your chance to pick-up all the crucial information for finding your way around campus. Not sure where your classes will be in Week 1? Come on a campus tour. Want to know the fastest way from the Library Lawn to the Unibar? Where's Esme's? What's a UNSW Union and why is it good? And where are the unisex toilets? Tour. They're run by Yellow Shirt volunteers – students just like you – and they're fun.

WIL ANDERSON – THE ROUNDHOUSE, TUESDAY COMEDY NIGHT – 7PM ONWARDS

Wil and Adam on Triple J breakfast saved many a painful early morning throughout my degree. Sadly, they've gone on to other things. Still, I know I'm looking forward to seeing Wil up on stage at O-Week. Fresh from his brilliant years on Triple J and his smash-hit with ABC TV's *The Glasshouse*, Wil Anderson will be making me laugh my ass off on Tuesday night, backed up by comedians Justin Hamilton and James Smith, and the freestyling comedy of live Thearesports. I'll be the guy literally dying of laughter up the front.

SARAH BLASKO – THE ROUNDHOUSE, WEDNESDAY NIGHT – 7:30 PM ONWARDS

I've seen Sarah play a few times – at intimate venues and on huge stages at Homebake and The Big Day Out. She's bringing her five-piece band to O-Week along with her rich and beautiful voice. Supported by Dan Kelly playing solo and unplugged, as well as Paul Greene, this promises to be an awesome evening of music. I can't wait to hear songs like *Don't U Eva* and *Always Worth It* from her debut album *The Overture & The Underscore* as well as some great tunes from her original EP. Haven't really heard Sarah before? This is your chance to discover something special.

FESTIVALÉ–THE PHYSICS LAWN THURS & FRIDAY, 11AM – 4PM

Carnival action at your university – what more could you want than fun times in the afternoon sun? There'll be a jumping castle of course, but you can also take on others in the gladiator duel or horizontal bungee. Have your fortune read by the Tarot Reader, get into a game of giant twister or just chill out with snow cones and fairy floss. Come to Festivalé and soak up the O-Week party mood – it's the perfect build up to the House Warming Party on Thursday and Eskimo Joe concert on Friday.

HOUSE WARMING PARTY, THE ROUNDHOUSE, THURSDAY FROM 8PM 'TIL LATE

If O-Week is all about making yourself at home at UNSW, then our massive Thursday night bash is about warming up the house in style. It doesn't matter if you're into RnB, the big hits, Aussie hip-hop or banging breaks, our house warming is the place to party hard. We've got Sydney's superstar breaks duo Kid Kenobi & MC Shureshock bringing their rocking beats to the breaks stage, rising star hip-hoppers Bliss 'n Eso on the mic and guaranteed crowd-pleasers Sefu & Matt Roberts. This night is going to rock and rock hard.

ESKIMO JOE WITH THE REDSUNBAND THE ROUNDHOUSE, FRIDAY –7:30 ONWARDS

\$10 for UNSW students

Look. This is going to be huge. Eskimo Joe is one of the biggest and best bands in Australia. You might have heard these guys a bit lately – their huge song of 2004, *From The Sea*, just came in at number 3 in the Triple J Hottest 100. They've also been blowing up the festival scene – I saw them at Splendour In The Grass, Homebake and Big Day Out and they were awesome every time. On Friday night Eskimo Joe and The redsunband will say farewell to O-Week and open the new uni year with a bang. Yeah, this is the only event in O-Week where UNSW students will be charged an entry fee, but seriously, ten bucks to see Eskimo Joe? That's just ridiculously cheap. In fact, you can bring your non-New South friends for just \$20 (that's still cheaper than their last Metro and Enmore gigs). These guys are an amazing live band – you'd be crazy to miss out on closing out the week with this incredible concert.

WHAT'S ON IN O-WEEK FEB 21ST -25TH

MONDAY

Faculty of Arts & Social Sciences Welcome

Learn about the school and find out all of the vital information you need to be a successful Arts student. You will also get a chance to meet other people from your degree. Includes free lunch and a tour of campus.

9:30am

Sir John Clancy Auditorium

Faculty of the Built Environment Welcome

Includes free lunch and a tour of campus

9:30am

Keith Burrows Theatre

Chillout Zone

Between the Roundhouse and Squarehouse. Shade, comfy seats, cool drinks, chilled beats, and a few games to amuse you.

11am-4pm

Roundhouse Back Beer Garden

Jumping Castle

Shaped like a big bouncy thing. We've had them at O-Week forever, and they're always fun. No spurs, please.

11am-3pm

Science Lawn

Lunchtime Band: Kaya

Get a cruisy start to our O-Week entertainment line up with some indie rock in the open air.

1-2pm

Library Lawn

Campus Tours

If you don't take one of these you won't meet people or know where stuff is.

Departs from the Morven Brown Courtyard & Naked Lady Lawn

2-4pm

Pool Competition

A doubles and singles comp will be running with some great prizes up for grabs.

2-4pm

Roundhouse

Yellowshirt Band

Covering some of your favourite tracks of all time. Not to be missed.

4:30-5:30pm

Roundhouse Beer Garden

Karaoke

Settling once and for all questions such as, "If you covered a Guy Sebastian song, would anybody hear?"

5:30-8pm

Roundhouse

Tug Dumbly

Performance poetry and political satire from a Triple J regular.

5:30-6pm

Beam's Club Bar, Roundhouse

Vice-Chancellor's Welcome to Parents

Mum and Dad can come along and hear the VC and go on their own tour of campus. Meanwhile you can go to the Roundhouse.

Tours from 5:30pm. Talking from 6:30 to 7:30pm, then more tours.

Sir John Clancy Auditorium

Open Air Cinema

'Ferris Bueller's Day Off'

A classic for anyone who has skipped class, or even considered it. Come along and help save Ferris.

8-11pm

Roundhouse Beer Garden

TUESDAY

Free Pancake Breakfast

As good an excuse as any to get here early. 9-11am. Anzac Gate

Faculty of Medicine Welcome

Includes free lunch and a tour of campus

9am

Biomed Lecture Theatre D

Faculty of Commerce & Economics Welcome

Includes free lunch and a tour of campus

9:30am

Sir John Clancy Auditorium

Faculty of the College of Fine Arts Welcome

The welcome includes a lunch for students, tour of the faculty and campus, an opportunity to have an introduction to COFA computer services and library and an introduction to AGNSW especially for COFA students.

Runs all day from 9:30am

CoFA campus, cnr Greens Road and Oxford Street, Paddington

Chillout Zone

Between the Roundhouse and Squarehouse. Shade, comfy seats, cool drinks, chilled beats, and a few games to amuse you. Similar to Monday, but with more cool.

11am-4pm

Back beergarden

Jumping Castle

Bouncy-bouncy. The world has seen many productions of Hamlet set in a stone castle, but none in a jumping castle. No shoes or really long toenails, please.

11am-3pm

Science Lawn

Lunchtime Band: Derwent River Star

A five-piece band featuring an eclectic mix of instruments and styles.

Come check it out. 1-2pm. Library

Lawn

Campus Tours

Useful if you ever need to find stuff on campus. And we all need stuff, at some time or other.

Departing from The Pavilions
2-4pm

NUTS Play

NUTS is the New South Wales Uni Theatrical Society, and this play will show you how that all works.

3-4pm
Roundhouse

O-Week Revue

Revue are all-singing, all-dancing comedy extravaganzas that are staged on campus each year. This is some of the best of 2004. Come see it.

4-5pm
Roundhouse

Thinking about studying overseas on Exchange?

If you've ever thought about spending some time at another university overseas during your degree, come along to this information session.

4-5pm
Room 1027 (Macaulay Theatre), Level 1, South Wing, Quadrangle Building

STS Workshop – Time Management

This workshop will show you how to make the most of those 24 hours we all have, through prioritising your work, research habits and useful time management tips for studying. Please register before the course at the U-Space office in the Blockhouse or on <http://www.union.unsw.edu.au/website/documents/Uspace/STSOnline.doc>.

5-7pm. Price: \$2. Venue: Matthews 302

STS Workshop – Presentation Skills

The workshop covers how to structure your presentation, creating and using visual aids and delivery. Please register before the course at the U-Space office in the Blockhouse or on <http://www.union.unsw.edu.au/website/documents/Uspace/STSOnline.doc>.

5-7pm. Price: \$2. Venue: Matthews 303

Air Guitar Competition

Not only is this for real, but we have an air guitar expert that we've brought in to judge this prestigious O-Week event.

5-6pm
Roundhouse

Theatresports

Some of Sydney's best professional improvisers will be, well, improvising. If you've never seen theatresports before, don't tell anyone. Just come along, and you'll learn.

6-7pm
Roundhouse

Comedy Night featuring

Wil Anderson

Wil is a comedy god. You may remember him from such funny things as the Triple J breakfast show, and The Glasshouse. Justin Hamilton and James Smith round out this night of funny stuff.

7pm onwards
Roundhouse
FREE for UNSW students, \$15 for everyone else.

WEDNESDAY

Free Pancake Breakfast

Back by popular demand, after a sell-out show on Tuesday.

9-11am
Anzac Gate

Faculty of Science Welcome

Includes free lunch and a tour of campus

9:30am
Sir John Clancy Auditorium

Faculty of the College of Fine Arts Welcome

The welcome includes a lunch for students, tour of the faculty and campus, an opportunity to have an introduction to COFA computer services and library and an introduction to AGNSW especially for COFA students.

Runs all day from 9:30am
CoFA campus, cnr Greens Road and Oxford Street, Paddington

Chillout Zone

Between the Roundhouse and Squarehouse. Still cool. How cool? I heard of a guy who grew an entire afro after spending three hours in last year's chillout zone. It's that cool.

11am-4pm
Roundhouse Back Beer Garden

Mechanical Surfboard

Through the wonders of modern technology, a device has been created that allows you to ride a surfboard without getting water in your ears.

11am-3pm
Science Lawn

Lunchtime Band: The Crustaceans

A 4-piece indie-rock group. Melodic, but upbeat. Worth a listen.

1-2pm
Library Lawn

Campus Tours

Useful for finding the secret, solid gold computer lab that legend tells is hidden somewhere on campus.

Departing from the Physics Lawn
2-4pm

Muzakal Chairs

The largest game of musical chairs in the southern hemisphere, with prizes and bad elevator muzak.

3-4pm
Roundhouse

Bar Bingo

Bar Bingo helps you learn. Last year we learned that saying "88 – two fat ladies," offends people.

4-5pm
Roundhouse

Postgraduate Coursework Welcome

4-6pm at Sir John Clancy Auditorium.

Jelly Wrestling

Yes, this is actual jelly wrestling with actual jelly. If you want to wrestle, we suggest a change of clothes.

5-6pm
Roundhouse Beer Garden

STS Workshop – Speed Writing

Learn a new method of abbreviation and other note taking techniques to enable you to take lecture and study notes more effectively. Please register before the course at the U-Space office in the Blockhouse or on

<http://www.union.unsw.edu.au/website/documents/Uospace/STSONline.doc>.

5-7pm. Price: \$2.

Venue: Matthews 302

STS Workshop – Career Networking

Between 70% and 80% of jobs are not advertised! The career-networking workshop is a great opportunity for you to kick-start your career building skills whilst still at university. Please register before the course at the U-Space office in the Blockhouse or on

<http://www.union.unsw.edu.au/website/documents/Uospace/STSONline.doc>.

5-7pm. Price: \$2.

Venue: Matthews 303

Crab Racing

One of the greatest sports known to man or crustacean. Come along and try and back a winner.

6-7:30pm

Roundhouse

Sarah Blasko invites you to an Intimate Night in the Round

After playing Australia's biggest festivals, one of our greatest songbirds comes to the Round with a five-piece band. Supported by Paul Greene and Dan Kelly.

7:30pm onwards

Roundhouse

FREE for UNSW students, \$7.50 for everyone else. This a licensed all ages event, so bring your ID.

THURSDAY**Free Pancake Breakfast**

The third and final appearance of this exciting event. You can start sleeping in again after this.

9-11am

Anzac Gate

Faculty of Engineering Welcome

Includes free lunch and a tour of campus

9:30am
Sir John Clancy Auditorium

Faculty of Law Welcome

Includes free lunch and a tour of campus

9:45am
Mathews Lecture Theatre A

Chillout Zone

Between the Roundhouse and Squarehouse. Still offering the same fine range of shade and chilled out tunes that we had on Monday. Again, this place is cool. Even if you're a science-geek and think you're an absolute zero you should come along, because as you know, absolute zero is the coolest you can be.

11am-4pm

Back beergarden

Festivalé!

The highlight of daytimes at O-Week, Festivalé! offers rides, games, free stuff, live performers and more. We put it on the big grass bit behind the Old Main Building.

11am-4pm

Physics Lawn

Theatresports

Presented by UNSW's own Studio 4, showcasing how you too can be funny on campus.

Midday-2pm

Roundhouse

World Music: Davood A. Tabrizi & The Far Seas

Multi-award winning Iranian composer Davood and his band The Far Seas present an amazing performance

embracing an array of cultures and musical styles.

2-3 pm

Roundhouse beer garden

Campus Tours

More informative than a website. Less flat than a map and has a scale of 1:1. More fun than not taking a tour where you get to find your way around and meet heaps of people.

2-4pm

Departs from The Pavilions & Roundhouse

Mature Age Mentoring Students Welcome

4-6pm

Mathews B Lecture Theatre

Yellowshirt Band

Covering some of your favourite tracks of all time. Not to be missed.

4:30-5:30pm

Roundhouse beer garden

STS Workshop – Speed Reading

This course aims to provide students with a basic introduction to the knowledge and skills required to speed read, cutting the amount of time that you spend doing mandatory reading. Please register before the course at the U-Space office in the Blockhouse or on <http://www.union.unsw.edu.au/website/documents/Uospace/STSONline.doc>.

5-7pm. Price: \$2.

Venue: Matthews 302

STS Workshop – Volunteering

Learn how to get involved in community volunteering activities and how they can help you develop skills important to your career success. Learn to speak in a language that will attract employers. Please register before the course at the U-Space office in the Blockhouse or on <http://www.union.unsw.edu.au/website/documents/Uospace/STSONline.doc>.

5-7pm. Price: \$2.

Venue: Matthews 303

**Commerce & Economics
Postgraduate Welcome**

5-8pm
Scientia Building

Endurathon

A series of events to test your wits and your guts. Great prizes for the person who can endure the most.
5:30-6:30pm
Roundhouse

Trivia

What is the plural of Elvis? A Roundhouse favourite. Lots of fun and a great warm-up to the night.
6:30-8pm
Roundhouse

O-Week Housewarming Party:

Featuring Breaks, House, Top 40, Live Hip Hop and RnB
Sydney's best DJs including Kid Kenobi & MC Shureshock, Sefu and Q45, plus Bliss n Eso live.
From 8pm
Roundhouse
FREE for UNSW Students, \$5 other students and \$15 everyone else. This is an all ages event, but bring your ID if you want to drink.

Festivalé!

All the cool stuff from the day before (rides, games, free stuff, live performers) plus some extra cool stuff that we saved for the final day.
11am-4pm
Physics Lawn

Vice-Chancellor's Welcome to Students

Prof Mark Wainwright, the Vice-Chancellor, welcomes new students to the UNSW community.
11-11:30am
Sir John Clancy Auditorium

What your Guild & Union do for you

Information session about the services offered by two of UNSW's student organisations.
11:30am
Sir John Clancy Auditorium

Jazz in the Beer Garden

This is one of UNSW's best traditions – live Jazz on Friday afternoons in the Roundhouse beer garden. Sit back and chill out with a drink.
1-2pm
Roundhouse Beer Garden

**Faculty of Commerce & Economics
Postgraduate Student Experience**

2-5pm
Rex Vowells Theatre

Big Screen Gaming

Head-to-head gaming on the big screens in the Roundhouse.
4:30-7pm
Roundhouse

DJs in the BeerGarden

The other one of UNSW's best traditions. We've got tradition coming out of our noses here at UNSW. Sit back and chill out even more with some funky tunes.
4:30-7pm
Roundhouse Beergarden

The O-Week Final Concert

Featuring Eskimo Joe
The perfect farewell to an amazing O-Week: our favourite band Eskimo Joe plays in the Round with support from The Redsunband and The Outfit.
7:30 onwards
Roundhouse
\$10 for students (tickets available on campus all week). \$20+bf for everyone else from Ticketek.
This is a Licensed All Ages event, so bring your ID if you want to drink.

Want To List Your Event In What's On?

It's easy. Just send an email to whatsonblitz@union.unsw.edu.au containing the following information about your event: Event name; Organiser; Location; Date; Time; Cost; and a Description of 50-100 words. The description is compulsory! You can also find a template on the union web site.

The **deadline** for What's On is *twelve days before* (always a Wednesday) the magazine is released (always a Monday).

FRIDAY

The Recovery Party

In the Chillout Zone at the back of the Roundhouse. You had a big night. But that's cool - we had a big night too. Come chill out and recoup some energy for the final day of O-Week.
10am-Midday
Roundhouse Back beer garden

FIRST YEAR, FIRST DAY



CAMPUS MAP



BUS STOPS



HELP DESK



ACTIVITIES



UNION FOOD OUTLETS



0-WEEK CENTRAL



STALLS

VISUAL BLITZ



MY WALL Photo by Hans Teja

Every week, students contribute their artwork to Visual Blitz and every year, Visual Blitz culminates in an exhibition of student work with prizes awarded to the winning entries. If you're in the habit of making creative statements then Visual Blitz is your canvas. Send your contributions for 2005 Visual Blitz to: blitzeditor@union.unsw.edu.au (Please include a 50 word explanation)

Visual Blitz Launch and prize ceremony for 2004 Visual Blitz Exhibition:

Tuesday 8 March, 5.30pm, Hutcheson Gallery, level one Roundhouse

Visual Blitz Exhibition: Mon-Fri, 11am-3pm, 9-18 March

Prizes to be awarded for 2004 include:

Commonwealth Bank



The University of New South Wales
Union

COFFEE, WANKING & SEX

THE STEREOTYPES OF BEING A UNI STUDENT By Jeff Forrest

You've spent the summer getting excited about coming to UNSW, you've rented all of the movies you could find about going to university and pretty much everyone you've spoken to for the last three months has had something to say on the matter. By now, your notion of what uni will be like probably resembles a cross between Mum and Dad's advice, the movie Road Trip and the TV show Felicity. But how true are all of these uni stereotypes? Let's take a look:

1. University is Big and Scary

Truth: Medium

We've all heard this one before. Somebody probably even trotted out the phrase "...little fish in a big pond," and talked about how it's like going into year 7 all over again. The fact of the matter is that UNSW has about 40 000 students and 5000 staff, making it roughly the size of a large town. The difference from high school, however, is that there are no big fish to be afraid of. Sure, you're a little fish. So is everyone else. If you're finding the place scary, the best solution is to meet a few people and carry a few friends around with you. They might be people in your degree or just some randoms you meet at the bar during O-Week, but they'll get you through any fears you may have.

2. Uni students drink a lot of alcohol

Truth: Medium

Compared to high school students, this is true. But remember that once you're at uni, you're probably old enough to buy alcohol any time you want and we do have a bar on campus. That being said, the notion that all uni students are pissheads tends to be a bit exaggerated. Sure, I've been to house parties with kegs, and

they were *good* parties, but if you think uni students spend every weekend at 'keggers' then it's time to take Road Trip back to Blockbuster (and stop using the word 'kegger').

3. Uni students drink a lot of coffee

Truth: High

Rumours that the cafés and coffee carts on campus are some of the most profitable in Sydney are unlikely to be exaggerated. Far more uni students get hooked on caffeine than beer. That being said, I love my coffee and I won't hear a bad word spoken about her. Whether you're up for a tall caramel latté or a primo (4 espresso shots in one cup), it's the caffeinated goodness that keeps you coming back for more. Every morning.

4. Uni students talk like wankers

Truth: Medium

Some more than others. If you're the type to get intimidated by a conversation addressing the deeper meaning of Foucault, then stop

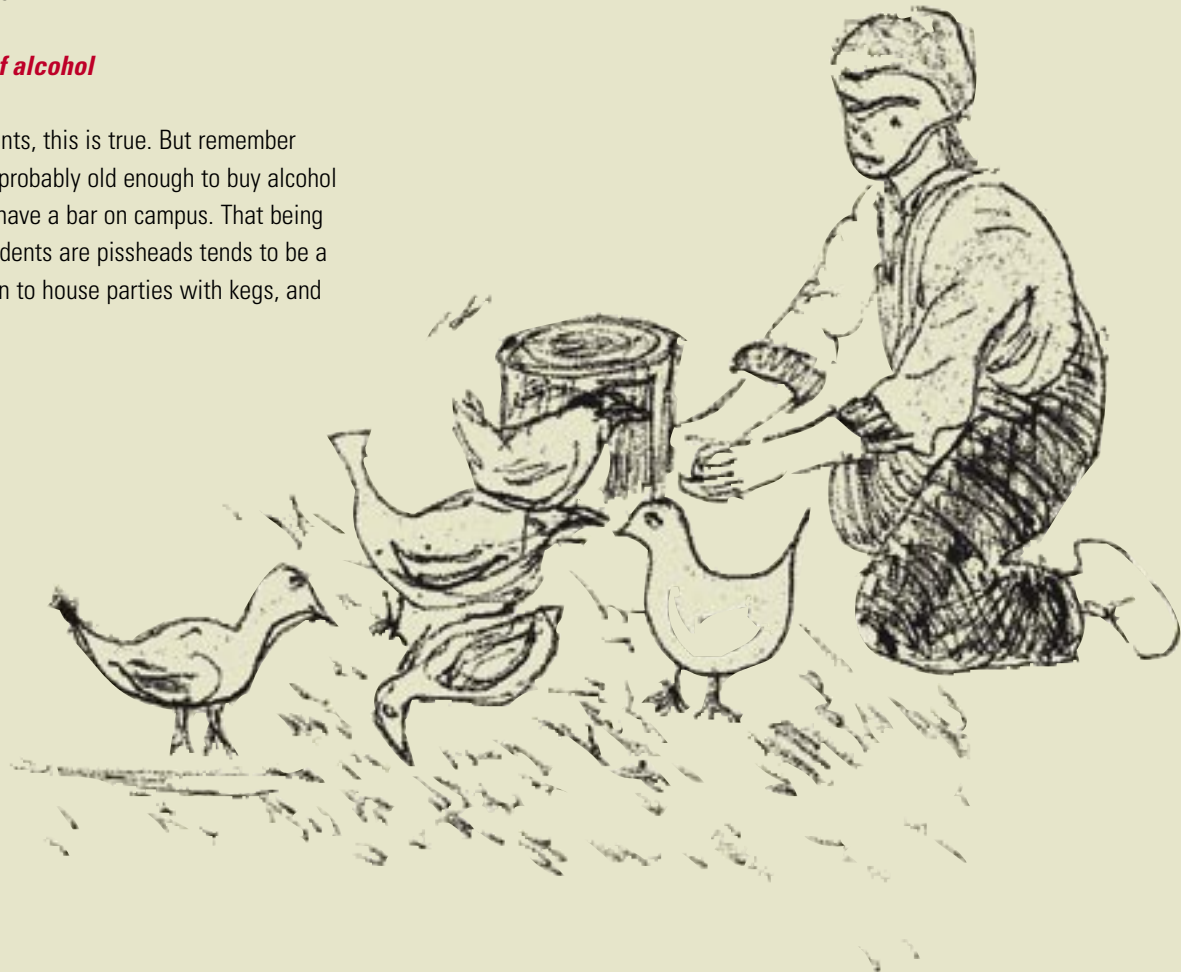

sitting with the wanker who's talking about Foucault. Uni is a great place to share ideas and to discuss some really seriously deep stuff, but don't feel like you have to, or like you have to do it all the time. Most uni students have a conversational repertoire fairly similar to anyone else their age – a tossed-salad of sports, reality TV, and quotes from The Simpsons. Sure, you'll get the odd drizzle of world politics or deconstructionist philosophy, but think of that as the French dressing that spices up an otherwise bland side-dish. Uni students also like to mix their food metaphors a bit.

5. Uni students have a lot of sex

Truth: Medium

Yes they get some, but not nearly as much as movies, magazines and expensive internet sites seem to be suggesting. In general the free love days are over. People will be outgoing and explore new boundaries at uni, but quite a lot of that exploration is done with clothes on (generally by drinking coffee and talking like wankers, see above). I certainly wouldn't expect uni students to get more sex than high-school students do these days, unless as a high school student you got none, in which case expect slightly more.

6. You'll have to motivate yourself at uni

Truth: High

The stories about there not being any teachers at uni to make sure you hand things in are true. That having been said, there's a much better chance that you'll actually enjoy what it is you're studying at uni, so motivating yourself shouldn't be too much of a problem. If you find that you're not enjoying a subject you're studying, feel free to ask yourself "why am I paying for this?" and promptly drop the subject. Remember, the theory is that you are at uni because you want to learn whatever your degree is teaching you. If you don't like it, change subjects. Or majors. Or degrees. I did. Twice. The fact is that if you can't enjoy a subject when you're only studying it 15 hours a week, and you're spending the rest of your time sitting on your arse on the Library Lawn or nipping down to Coogee for a swim, what makes you think it will be any more bearable when you're doing it 40 hours a week as a job?

Anyway, back to motivation. You will need to learn how to chase yourself to get assignments in. This process may get much easier once you fail one, and realise that no, your tutor won't nag you about that essay.

7. Uni students are radicals

Truth: Poor

Over the past several years university has become increasingly about getting a solid education and finishing your degree with a high-paid job. This process has tended to have a negative effect on point 7, as well as points 2, 3, 4, 5 and on campus life in general. Your parents, friends or former teachers may think uni students are crazy radicals these days, but this is only because many of those people haven't had any original thoughts since Wham! last had a song in the Top 10.

8. Your uni years are the best years of your life

Truth: How the hell should I know?

Let me take a moment to remind you that: a) I have no idea about your life, and b) I'm only 24 so I'm not even sure if they are going to be the best years of mine. Are they the best years of my life to date? Without a doubt. It may take you a while to find it and you may have to look past the glass fronted buildings and manicured lawns, but UNSW has a warm and embracing culture that makes it an amazing place to spend a few years. So long as you've got the guts to try a few different things: join some clubs; talk to some strangers; maybe do some volunteering, you'll find that being a uni student is possibly the most fantastic thing that has ever happened to you.

For now, have fun in O-Week, drink plenty of coffee and beer and talk like a wanker. Make friends, be a radical, and try and make sure that when you leave uni at the end of your degree you've got a whole shitload of stories to tell about how much fun you had. Those memories will get you further than a solid education any day of the week.

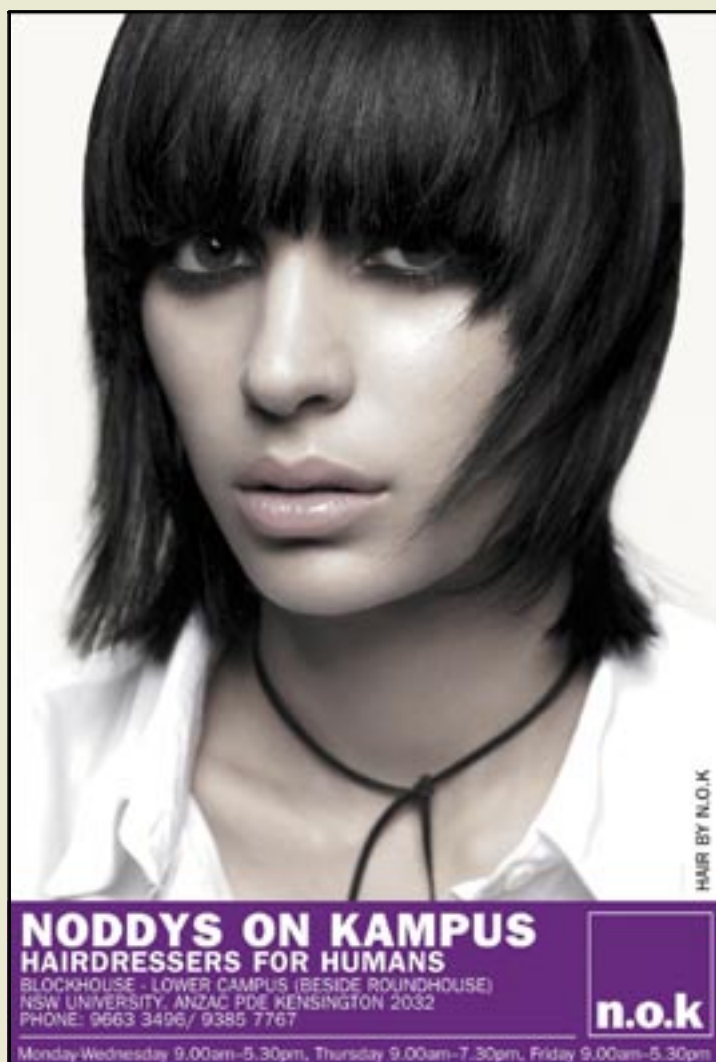

HAIR BY N.O.K

NODDYS ON KAMPUS
HAIRDRESSERS FOR HUMANS
BLOCKHOUSE - LOWER CAMPUS (BESIDE ROUNDHOUSE)
NSW UNIVERSITY, ANZAC PDE KENSINGTON 2032
PHONE: 9663 3496 / 9385 7767

n.o.k

Monday-Wednesday 9.00am-5.30pm, Thursday 9.00am-7.30pm, Friday 9.00am-5.30pm

KINGAROY MEANS NUTS

By April Smallwood

Hopping off the Virgin Blue plane that Monday morning the waiting air was like steam. Anyone ever flown with Virgin Blue? These employees are the most carefully selected bunch of young people I've come to encounter. Just the right amount of jolly and gay. Joyous, I mean.

I am 21 years old and after many years I find myself back here, left to face the dry heat and the witty, biting humour of my dad in Kingaroy, the proud peanut capital of Australia, which if I were to wrap up in a teeny nutshell would be a south western Queensland rural town a good three hours from Brisbane and a solid two hours from any natural body of water, with a small and well developed town centre surrounded by fertile agricultural areas, brown snakes and big trees. Now I've never been a hefty country fan, but let me if I may impart a few insightful facts about this beloved Kingaroy.

So the peanut thing, they sell a most bizarre selection of them. Who knew you could buy smoked bacon, crispy chicken, salt and vinegar and brown sugar flavoured? And these peanuts, they are bloody huge. Think of your pinkie, then halve it. Ruthie Rimes, a local with a contagious passion for peanuts was quick to tell me why. "They're huge because they don't grow on trees like true nuts do", she says. "Instead they belong to the legume family and grow on a small bush or vine underground".

Add that to your fact file.

The day I arrived so did a storm. The wind here assaults you. The crack of thunder that follows lightning strikes the ear like something from a Black Sabbath concert. Purely piercing. At its worst my arms would tire from having held them up against my ears for hours straight.

The people out here are more relaxed than their cows, which is relieving after being in Sydney and Sydney alone for great lengths. Out here, people are mostly concerned with efficient garbage disposal, keeping their water tanks full and their cattle tick free. It's really a different life. The sun rises at 3:50am and birds at that time are far too loud to ignore.

Only seeing my Dad two weeks a year, I tend to tune into the idiosyncrasies that make him truly unique. The Aussie in him tends to end most stories with "How's 'at grab ya?" Which I find personally most amusing. Since my Daddy-O was born in the 30s, the internet or even a computer remains some elusive phantom to him that he is happy to remain in the dark about. His wife told him she lost her mouse and he handed her a piece of cheese on a plate.



The dogs here don't bite but rather lick. I hear it's the salt in our sweat-filled skin they long for. The canteen at the local pool in Kingaroy still sells various childhood lollies such as red frogs, sherbet bombs and gobstoppers. Yep, that's what kinda town it is. Shucks.

Green frogs hang out in gangs of seven, with googly eyes and suction cup feet that aid them in sticking to kitchen windows. Roads are long, narrow and quiet. Alongside them are fruit vendors selling the most spectacular watermelons and pineapples you've ever tasted. Cheap as peanuts, too.

Being a small town with a population of eight thousand, Kingaroy amusements can be somewhat limited. Jodie Coffey, a 2004 high school graduate informed me that a lot of young kids just out of school are keen to shoot through and head to universities far far away, Brisbane or Toowoomba being the most popular. A lot of people venture here to retire and so find their peace in a serene paddock raising chickens and growing macadamia. Hence many youngsters with interests far more risqué are crying boredom.

Spending a portion of my generous uni break in Kingaroy brought to mind the fact that my family tree is full of nuts. I have a step-mother with this bizarre habit of screaming passionately at Lleyton when he screws up, a father with a horrendous breakfast call of "Come Oooon!" and a dog that for the life of him refuses to stop licking or biting or eating random house objects. But being there I began to understand that one can manage to find merriment in the oddest of places - at a souvenir van by the side of a dusty road, a local pool in town, lying on bare grass staring at telephone lines in the sky and yes, even in the peanut capital of Australia.

A nut walks into a bar. Ouch.

ADVICE FROM A GRIZZLED UNIVERSITY VETERAN

By Patrick Coyte

The fact that you're reading this article right now probably means that you're enrolled at university. I respect that; it's that sort of courage our society needs. While your high school buddies walked outta there with an HSC in their hand and went to work full-time in a shoe shop for the rest of their lives, you had the raw determination to stick it out.

But if it's your first year in this break-neck, dog-eat-dog, cat-eat-cat, cat-eat-dog, no-second-chances academic jungle, you might not have known what you were getting yourself into when you signed your name on that dotted line. If you read my advice, and then you might just last five minutes before this place chews you up and spits you out. Who knows, you might even get out of this murder alive, if you're one of the lucky ones. So pay attention, see.

Lectures

When I was a young and idealistic first-year, some geezer told me that I should attend lectures. I didn't listen, and guess what? *I still have the scars.* That's because lectures are the most important part about university – besides tutorials, seminars, assignments, and exams. What's more, they're the hardest. I remember being in one lecture where some guy got so bored *he couldn't feel his legs*, and they had to take him back to his family on a stretcher. Poor bastard was only a kid. But that's lectures for you.

Steps

There are a lot of steps in this place. Oftentimes folks come here expecting an easy ride, but this ain't no prissy, easy livin', escalator installing Sydney Uni. Here at UNSW we have to walk. It doesn't matter if you're so hot and tired you feel like your head is going to explode and spew algebra facts like a damn fountain, you've gotta keep walking up, up and up. Or conversely, down, down and down.

Friends

People are gonna try and feed you some line about university being candy-eating land of unlimited friends. Let me tell you - it's a load of horse-puckey. Don't get too close to anybody at university, because they're here one day and gone the next. Doesn't matter how many scrapes you've got through together - tomorrow either one of you could be cut down by a surprise revision quiz. Remember that, and remember that the ones who do stick around the longest are usually the most annoying ones anyway. Sometimes you'll just want to crack and trip them over on their way down to the front of the lecture theatre, but who'd be the bad person then? You'll be discharged quicker than you can say compound skull fracture.

Well, that's all from this grizzled university veteran. Be thankful I gave you the heads-up, kid, and don't forget to keep your head down. But don't slouch, you'll look like a damn fool.



plug 'n' save o week specials!



for the home
Full range of ex rental TV's, fridges, washers and microwaves priced to clear from
\$49.95



iMac Madness
buy any of our massively discounted iMac's and get a blubyte 128mb MP3 player for only
\$35.00* one per customer on presentation of this ad



Notebooks
from **\$690**
Sydney's largest collection of ex demo and refurbished notebooks ..flip out at the prices



entertain yourself
Bargins galore on our range of surround sound and DVD players all with 12 mth Wty



256MB **\$45.95**
flash drive v2.0
blubyte products...
flash drives, mp3 players, portable dvd players and speaker sets

183 Anzac Parade Kensington Ph 9663 0416



Pictures for illustration only; Logos remain the property of their respective owners. Stock and prices subject to change without notice. Errors and Omissions Excepted.

University Snakes & Ladders

Blitz Magazine understands that you may not know what to expect from your first year of university. This is why we have put together this board game that condenses an entire year of university into less than half an hour. If you complete it, we guarantee that you'll be prepared for anything* university life throws at you!

Unlike university life, the rules of this game are simple: Find yourself a couple of friends, counters and a die; take turns rolling the die and moving your counter toward the finish; follow the instructions written in the squares you land on; the first player to reach the finish wins. Good Luck!

*Exceptions apply.

Game written by Ben Smyth

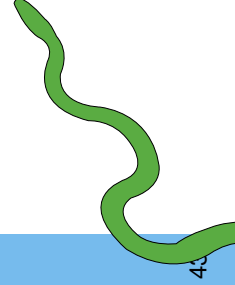
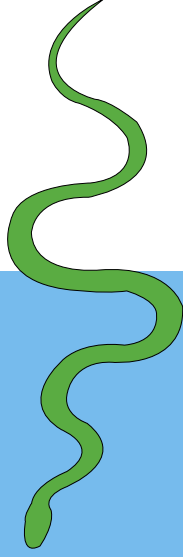
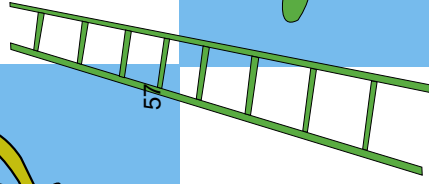
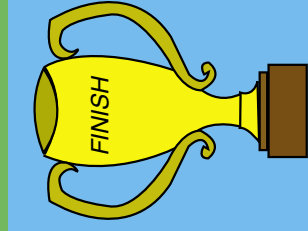

57	54	53	52	51
Go to the Round house for "Just one beer..." and end up drinking just one beer <i>Advance 2 spaces</i>	After having an enquiry referred from one university department to another, you are eventually referred back to the department you started with <i>Go back 4 spaces</i>	Your piercing and highly distinctive ring-tone declares your individuality a little too loudly when your mobile goes off during a lecture <i>Go back 3 spaces</i>		
44	47	49	48	50
Go to the Round house for "Just one beer..." and end up drinking just one beer <i>Advance 2 spaces</i>	Discover that sliding down rails will destroy your pants in less than three minutes <i>Go back 2 spaces</i>			Turn up to a tutorial completely unprepared, but miraculously nobody asks you a single question <i>Advance 2 spaces</i>
43	46	39	38	37
Go to the Round house for "Just one beer..." and end up drinking just one beer <i>Advance 2 spaces</i>	Perhaps due to chance but probably due to malice, all of your assessment tasks are due on one day <i>Go back 3 spaces</i>	Decide that the band on the library lawn is much more interesting than your class <i>Miss a turn</i>		Nine am lecture is located in quiet lecture theatre with dim lighting, leg room, comfy padded seat...zzzzzz <i>Advance 2 spaces</i>
42	41	40	39	38

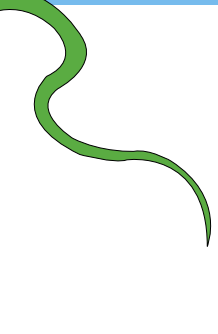

Resolve a potentially violent disagreement between rival gangs with a Dance Dance Revolution tournament
Advance 1 space

Knocked out cold on library lawn by rogue hackey-sack
Lose a turn

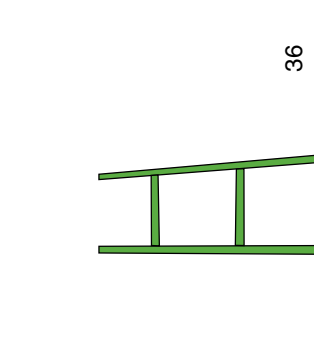
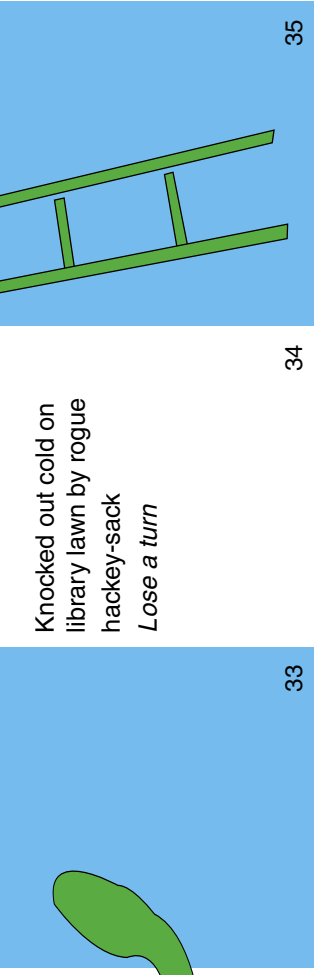

Hotmail site goes down, instantly freeing up 95 percent of library computer resources
Advance 3 spaces

Once-in-a-millennia planetary alignment causes your faculty office to be open when you visit it
Advance 2 spaces

Unable to get to class in time because your path is constantly blocked by meandering, oblivious iPod wearers
Go back 2 spaces

Library fire drills deliberately scheduled for last hour before your assignments are due
Go back 2 spaces

Discover that sliding down rails will cut three minutes off your trip to lower campus
Advance 2 spaces

Your lawn snooze time begins five minutes before the activation time for the sprinkler system
Go Back 2 spaces

Your lecturer fails to turn up to class. Lunch break is extended by 45 minutes.
Advance 1 space

Score a HD in an assessment for no apparent reason
Advance 3 spaces

Score a HD in an assessment for no apparent reason
Advance 3 spaces

Your tutorial group is full of hotties. Attendance record improves
Advance 2 spaces

Hotmail site goes down, instantly freeing up 95 percent of library computer resources
Advance 3 spaces

Library fire drills deliberately scheduled for last hour before your assignments are due
Go back 2 spaces

Discover that sliding down rails will cut three minutes off your trip to lower campus
Advance 2 spaces

Your lecturer fails to turn up to class. Lunch break is extended by 45 minutes.
Advance 1 space

Hotmail site goes down, instantly freeing up 95 percent of library computer resources
Advance 3 spaces

Once-in-a-millennia planetary alignment causes your faculty office to be open when you visit it
Advance 2 spaces

Unable to get to class in time because your path is constantly blocked by meandering, oblivious iPod wearers
Go back 2 spaces

Library fire drills deliberately scheduled for last hour before your assignments are due
Go back 2 spaces

Discover that sliding down rails will cut three minutes off your trip to lower campus
Advance 2 spaces

Your lawn snooze time begins five minutes before the activation time for the sprinkler system
Go Back 2 spaces

Your lecturer fails to turn up to class. Lunch break is extended by 45 minutes.
Advance 1 space

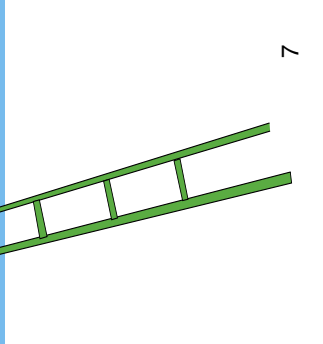
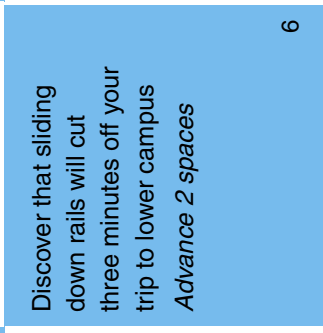
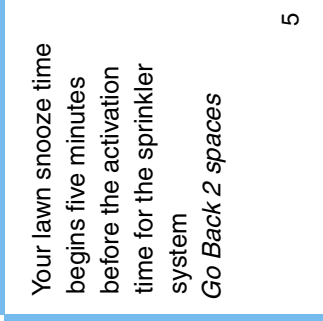
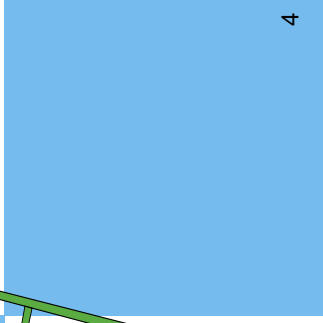
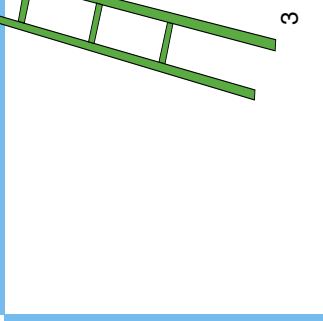
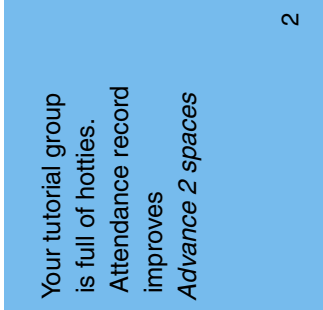
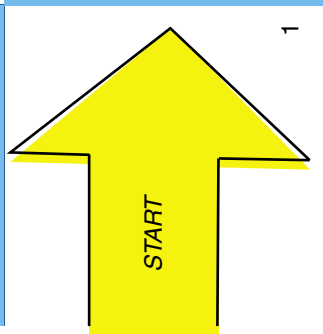

30

31

32

33

34

35

36

29

28

27

26

25

24

23

16

17

18

19

20

21

22

15

14

13

12

11

9

8

1

2

3

4

5

6

7

CALLING FOR AUSTRALIA/NZ ENTRIES NOW

WIN HUGE CASH PRIZES AND A TRIP TO JAPAN

TOTAL FINALS PRIZE POOL WORTH USD\$215,000

YOKOHAMA.
JAPAN

Challenge your mind, your creativity and your boundaries. Create and enter the project you've always dreamed of for the opportunity to win huge prizes at the Imagine Cup 2005 global Finals in Japan. Prizes for 1st Place are:

- >> Software Design Invitational USD\$25,000¹
- >> Office Designer Invitational USD\$18,000²
- >> Algorithm USD\$8,000³
- >> Technology Business Plan USD\$8,000²
- >> Rendering USD\$8,000²
- >> IT USD\$8,000⁴
- >> Web Development USD\$8,000²
- >> Visual Gaming USD\$8,000⁵
- >> Short Film USD\$8,000²
- >> IT - High School USD\$5,000⁴
- >> Web Development - High School USD\$5,000²
- >> Visual Gaming - High School USD\$5,000⁵

Register now:

www.imaginecupasia.com

or SMS* your email address to 0409 459 014 to receive info in your inbox

IMAGINE A WORLD WHERE TECHNOLOGY DISSOLVES THE BOUNDARIES BETWEEN US.



For the Imagine Cup 2005 Calendar, Contest Rules and Contest Details, visit www.imaginecupasia.com

*SMS only available to Australian students. Entry is open to university and high-school students 14+ who are actively enrolled at accredited educational institutions. Terms and conditions apply. 1. May 1 2005 Project due 2. April 1 2005 Submission due 3. March 1 2005 Round 1 ends 4. March 1 2005 online quiz ends 5. March 1 2005 Round 1 Submission due. The Promoter is Microsoft Pty Limited of 1 Epping Road North Ryde NSW 2113. ABN 29 002 589 460

CLASSIFIEDS

Send your classifieds to blitzeditor@union.unsw.edu.au There is a 100 word limit.

Want to be part of Roundhouse events, promotions, weekly activities and at the same time make new friends, receive free lunch vouchers, gig tickets and party invitations? Not to mention enhancing your marketing skill base. If this sounds like something you'd be interested in, email: hypesmiths@union.unsw.edu.au or check out the web www.unswroundhouse.com

Co-optee positions on Union committees

The Union has several committees that support the Board. These committees are made up of Board Members and Co-optees. Any Union member may be a co-optee.

Co-optee positions are suitable for students who have seen how the Union and campus life operate and feel that they can contribute. You will work with Board members and Union management to develop policy and strategy for this large organisation.

For an information pack and application form, visit the Union website (www.union.unsw.edu.au) or contact Dave Hume, Union President, on 9385 7724 or u.president@union.unsw.edu.au. Applications will close at 5pm on Friday, 11 March 2005 (the end of week 2).

UNSW Union International Cookbook Competition 2005 It's time to enter your favourite recipe! Enter your most mouth-watering recipe and story to be published in the Union's fabulous International Cookbook competition 2005. Get cooking! Tasty prizes,

very tasty cookbook

Enter BEFORE Friday 25 March Week 4. See www.union.unsw.edu.au, or for further information email:

internationalcookbook@union.unsw.edu.au

Public speaking course

– The key to confidence, leadership & success. For students, staff & public, in a friendly and supportive environment. Five evenings, once a week starting march 2005. Cost is \$90. Organised by Toastmasters: UNSW Professional Speakers Club. Contact Rita on 0402457198, Dennis on 9314 3654 or email toastmasters_unsw@yahoo.com.au.

CISCO Certified CCNA Courses starting Week 2 on campus. Designed to empower you in the computer networking field. No previous experience or qualifications to start on the path to become qualified as an industry recognized Cisco Certified Network Associate (CCNA). The program is designed to help students gain real-world technology skills and is an excellent opportunity for hands on CCNA training at the UNSW campus with real(not just simulated) Cisco equipment.

The Semester 1 evening classes will start Week 2 each Tuesday 6-9pm from 8th March for a total of 13 weeks. Contact:

cisco_ccna@ee.unsw.edu.au, (02) 9385 4504/4940,

<http://academy.ee.unsw.edu.au>

A special thanks to all of our sponsors who have contributed to the success of O-Week 2005. Without their kind support O-Week would not be possible.

Major Sponsor



* Coca Cola * Coles Myer * Card Call * Lipton Ice Tea * Australian Jockey Club * Scooter Central * Playfair Visa & Migration Services * Mascot Superbowl * Red Bull * See * National Australia Bank * Student Marketing Australia * Lexar * Apple * Commonwealth Bank * Dairy Farmers * Cox Marketing Solutions * ANZ * Making Waves * Westpac * State Transit * Fantastic Furniture * Anying International * McDonalds * Beiersdorf * Duo Condoms * Cinema Paris * CCUSA * Publicis Mojo * Tooheys * Australian Computer Society * Momentum Dance Studio * STA Travel * Footlocker * Sydney Morning Herald * Initiative * Domain * Pfizer * Listerine Blister Paks * On Campus Promotions * Student flights * Microsoft * Mad Man Entertainment * NRMA * Plug N Save * Backstage Media * Captive Media APN Outdoor * Madman Cinema * AMP Royal Randwick * Sydney Symphony * International Exchange Programs * 3AM *

On Campus Sponsors

* Unimac * Sports Association * Noddy's on Kampus * Unigym * Australia Post * UNSW Library * Liquid * Café Brioso * Community Alliance Unicom * UNSW IT Service Desk * UNSW Faculty of Engineering *

VOX POPS

“WHAT ADVICE OR TIPS WOULD YOU OFFER TO FIRST YEAR STUDENTS?”

With the O-Week Yellow Shirts



KIRSTIN You're only here for three, four, seven or maybe ten years. Have fun, and remember that the 891 doesn't just stop at Gate Two.



TOM
Don't forget to breathe



GLENN
A life best lived is lived in company.



DANIEL
It's a cliché, but work hard, play hard (and don't forget Thursdays at the Roundhouse)



MIKE Come to O-Week, learn about the place where you'll be spending the next few years and discover how much you can get out of being part of the UNSW community.



HENRY
Visit CoFA!
(The College of Fine Arts in Paddington)



CLAIRE
Turn back * pages, read the O-Week What's On, and go to stuff.



MATT
Uni's not just a degree. Put in what you can, and enjoy it.



BRIDGET
Talk to everyone, and don't be scared to talk to randoms



KEN
Get involved in stuff. You'll meet people and through them you'll meet more. It's a chain reaction!



EMMA Forget about your UAI - it doesn't mean anything anymore.



ROSIE Discarded pizza boxes are an inexpensive source of cheese...
BELINDA ...As are wrappers from Tasty Bites.



ALEC High school is over - you can be whoever you want to be.

**Great taste
just an instant away**



Indomie Mi goreng
Spicy Beef Flavour, Satay Flavour
& Hot Fried Noodles

**New Flavours
of Mi Goreng**

Easy & Simple
4 steps to enjoy
the great taste
of Indomie Mi Goreng

-  **1** Boil noodles in briskly boiling water and simmer for 3 minutes.
-  **2** Mix seasoning powder, oil, sweet soy sauce and chili powder (according to taste) on a bowl while noodles are being cooked.
-  **3** Remove noodles from water and drain well.
-  **4** Stir noodles with the seasonings and mix well. Ready to serve.



Garnish with sunny side eggs, fried chicken, sausage & meat ball or shrimp according to your preference.
Your delicious Indomie Mi Goreng is now ready to be enjoyed.

Also available in several delicious soup-based flavours :

- Shrimp Flavour
- Soto Mie Flavour
- Seafood Flavour
- Special Chicken Flavour
- Chicken Curry Flavour
- Vegetable Flavour
- Onion Chicken Flavour
- Meatball Flavour
- Chicken Flavour

Available at Woolworths, Coles (Asian Food Isle) & Asian Groceries.



My choice...
Indomie®

Can't afford a hangover cure?



Spend less on your mobile.

18¢
TEXT

18¢
TALK
per 30secs plus
25¢ flagfall.

Any mobile. Any network. Any time.*



Just say the word **'yes'**
OPTUS

Conditions apply, including: *Text+Talk 18¢ per text, 18¢ per 30 seconds to any mobile and call connection fee of 25¢ applies. Only applies to calls and standard text made and received within Australia. Text excludes International, Premium and third party Text services. Offer ends 31/03/05 unless withdrawn earlier.

OPT4427